

PEOPLE'S DEMOCRATIC REPUBLIC OF ALGERIA
MINISTRY OF HIGHER EDUCATION AND SCIENTIFIC RESEARCH
MOHAMED BOUDIAF UNIVERSITY - M'SILA

FACULTY MATHEMATICS
AND COMPUTING SCIENCE

COMPUTER SCIENCE
DEPARTMENT

N° :



DOMAIN: MATHEMATICS
AND COMPUTING SCIENCE

SECTOR : COMPUTER SCIENCE

OPTION : SIGL

Thesis presented for obtaining

Academic Master's degree

By: Khalfallah Wafa

Benzerrouk Sabrine

Entitled

**ROUTING IN WBANs
CLASSIFICATION AND IMPLEMENTATION**

Submitted: 22/06/2023 before the jury composed of:

Mr: Guesmia Salah	University of M'sila	President
Mr: Bahache Mohamed	University of M'sila	Supervisor
Mr: Attir Azzedine	University of M'sila	Examiner

University year: 2022/2023

Thanks

First of all, we would like to thank God Almighty

The Almighty, the Merciful, because He gave us the will, the strength and the courage to overcome all the difficulties in order to accomplish this work.

We would also like to express our deepest gratitude, concern and sincere thanks to our supervisor, **Mr. Mohamed Bahache**, for his patience, guidance, assistance and guidance throughout this period. His skill made this work particularly interesting.

My sincere thanks to all the professors of the Department of Mathematics and computer science and to all those who guided their comments, advice and criticism, and agreed to meet me and answer my questions during my research.

Finally, thank you to everyone who, directly or indirectly, helped us make it happen.

Dedications

I would like to express my gratitude and thanks to my father, may God have mercy on him, and to my mother, may God protect her, without whom I would not have reached here.

I thank my sisters Sarah and Ikram and my brothers Ismail, Marwan, yakoub, Ishak, Ibrahim and Youssef who have always been by my side, thanks for their great support and encouragement.

Finally, a special thanks to my girlFriend at work « Wafa « And my other friends for their encouragement.

To all of these, I offer my thanks, respect and gratitude.

Benzerrouk sabrine

Dedications

I dedicate this humble work to My dear father and my dear mother,

Who never stopped encouraging me during these years of study and supporting me so that I could achieve my goals, may God protect them both.

My sisters Amal, Anfal and Fatima, and my brother Abdul Karim.

Special thanks to someone dear to me who supported me throughout my master's studies.

My friends sabrine, hadjer, rayane,warda,sara and marwa.

Khalfallah wafa

Abstract

The Internet of Things (IoT) has become among the most emerging technologies in various fields such as medical monitoring, electronic implants, creation of small and inexpensive microelectronic components etc. Technology has played an important role in every aspect of our lives. Wireless Body Area Networks or WBANs is used for automatic and electronic monitoring of human physiological parameters. Routing is one of the principal challenges facing the use and the design of these networks , our aim in this thesis is to study and classify the exiting routing protocols in this type of networks, from one side and implement it in one of the existing simulators dedicated for this type one networks. It is a Cooja emulator

By using a routing protocol dedicated to the internet of things RPL .

Key words: IoT,WBANs,Physiological parameters,Routing,Cooja , RPL .

Résumé :

L'Internet des objets est devenu l'une des technologies les plus émergentes dans divers domaines tels que la surveillance médicale, les implants électroniques, la création de composants microélectroniques petits et peu coûteux, etc. La technologie a joué un rôle important dans tous les aspects de nos vies. Les réseaux corporels sans fil ou WBAN sont utilisés pour la surveillance automatique et électronique des paramètres physiologiques humains. Le routage est l'un des principaux défis auxquels sont confrontés l'utilisation et la conception de ces réseaux, notre objectif dans cette thèse est d'étudier et de classer les protocoles de routage existants dans ce type de réseaux, d'un côté et de l'implémenter dans l'un des simulateurs existants dédiés pour ce type de réseaux. C'est un émulateur Cooja

En utilisant un protocole de routage dédié à l'internet des objets. RPL .

Mots clés : l'Internet des objets, WBAN , paramètres physiologiques,Routage Cooja , RPL .

ملخص

اصبحت انترنت الأشياء من بين التكنولوجيات الأكثر انتشارا و في مختلف الميادين , مثل المراقبة الطبية، الغرسات الالكترونية و انشاء مكونات الكترونية دقيقة و غير مكلفة الخ. شبكات الجسد اللاسلكية هي شبكات تستعمل في المراقبة الاوتوماتيكية و الالكترونية للوسائط الفيزيولوجية لجسم الانسان. بروتوكولات التوجيه هي احدى التحديات التي تواجه تصميم و استعمال هذا النوع من الشبكات. نهدف في أطروحتنا هاته دراسة و تصنيف مختلف البروتوكولات الموجودة في هذا النوع من الشبكات اللاسلكية هذا من جهة ، و من جهة اخرى تحقيق او انشاء هذا النوع من الشبكات في بيئة محاكاة معروفة و موجهة لهاته الشبكات , وهو المجاكي COOJA.

وذلك باستعمال بروتوكول توجيه مخصص لانتانات الأشياء RPL.

الكلمات المفتاحية: انترنت الأشياء، شبكة منطقة الجسم اللاسلكية، المعلمات الفسيولوجية، التوجيه Cooja
.Rpl .

General introduction	01
Chapter1: Wireless body area network basics	
. Introduction	04
1. Definition of WBAN	04
2.Sensor Node Architecture	05
3. Body sensor Network architecture.....	06
4. WBAN network topologies.....	07
5. WBAN communication technologies.....	08
5.1. Bluetooth.....	08
5.2. ZigBee.....	08
6. Difference between WSNs and WBANs.....	09
7. WBAN Applications.....	09
7.1 Medical Applications.....	09
7.2 Non-Medical Applications.....	09
7.2.1 Sports.....	09
7.2.2 Military.....	10
8. WBAN Challenges and Implementation Problems	10
8.1. WBAN Challenges.....	10
8.2. Implementation Problems in WBAN	10
8.2.1. Physical Problems	11
a) Sensitivity of Sensor.....	11
b) Battery Charging and Maintaining Energy Consumption	11
c) Body Data Collection Strategy	11
Conclusion	11

Chapter 2 : Routing Protocols for WBANs

- Introduction.....13**
- 1. Classification of Routing Protocols in WBANs.....13
 - 1.1. Temperature based Routing protocols13
 - 1.1.1. Thermal Aware Routing Algorithm (TARA)14
 - 1.1.2. Least temperature routing (LTR)15
 - 1.1.3. ALTR (Adaptive Least Temperature Routing)15
 - 1.1.4. LTRT (Least Total-Route Temperature)16
 - 1.1.5. HPR (Hotspot Preventing Routing)17
 - 1.1.6. Routing algorithm for networks of homogenous and
Id-less biomedical sensor nodes (RAIN)17
 - 1.1.7. TSHR (Thermal-Aware Shortest Hop Routing)17
 - 1.1.8. A New Energy-Efficient Routing Protocol (M-ATTEMPT)18
 - 1.2. QoS-Aware Routing Protocols20
 - 1.2.1. Routing Service Framework.....20
 - 1.2.2. New QoS and Geographic Routing (LOCALMOR)20
 - 1.2.3. Data-Centric Multi-Objectives QoS-Aware Routing (DMQoS) ...21
 - 1.3. Cluster-Based Routing Protocols22
 - 1.3.1. Hybrid Indirect Transmission (HIT)23
 - 1.3.2. Any Body.....23
 - 1.4. Postural-Movement-Based Routing Protocols.....24
 - 1.4.1. On-Body Store and Flood Routing (OBSFR)24
 - 1.4.2. Opportunistic Routing.....25
 - 1.4.3. Energy Efficient Thermal and Power Aware Routing (ETPA)25
 - 1.5. Cross-Layered Routing Protocols26
 - 1.5.1. Wireless Autonomous Spanning Tree Protocol (WASP)27

1.5.2. Time zone Coordinated Sleeping Scheduling (TICOSS)	27
1.5.3.BIOCOMM.....	28
Conclusion.....	29
Chapter 3 : WBANs Implementation	
. Introduction.....	31
1.Working environment and Development tools	31
1.1. VMWAREWorkstation.....	31
1.1.1. What is the VMware used for ?.....	32
1.1.2. What Does VMware work ?.....	32
1.2. CONTIKI	32
2. Protocol working stages	32
2.1. Installing Contiki 2.7.....	32
2.2. Cooja.....	33
3.How to create the IoT Network Scenario using Cooja Simulator.....	33
4. Simulation and performance evaluation.....	37
4.1. RPL.....	37
4.1.1 simulation parameters	38
4.1.2. static network stability.....	38
4.1.3. Multiple Sink Node.....	39
4.1.4.Result and evluation.....	39
a. Network Scalability.....	40
b. Multiple Sink.....	42
Conclusion	43
General conclusion.....	45
References

Figures List

- Figure 1 : wireless body area network
- Figure 2: sensor-node architecture.
- Figure 3 : The architecture of wireless body sensor networks.
- Figure 4: The structure of topologies in WBAN.
- Figure 5 : An example of TARA.
- Figure 6 : An example of LTR.
- Figure 7 : An example of ALTR.
- Figure 8 : An example of LTRT.
- Figure 9 : System architecture of LOCALMOR, (a) On-body network, (b) In-hospital network.
- Figure 10: Network architecture for DMQoS.
- Figure11: Hierarchical structure of cluster-based routing.
- Figure12 : Network Architecture of OBSFR.
- Figure13 : Network on the body (b) Abstract view of the network.
- Figure14 : Categories of WBAN routing protocols.
- Figure15 : VMWare Workstation 17 Player.
- Figure16 : Launch cooja from terminal.
- Figure17 : Creation of a new simulation.
- Figure18 : Network simulation.
- Figure19 : create new mote.
- Figure20 : Compilation terminated.
- Figure21 : Add motes.
- Figure22 : Node in the network area.
- Figure23 : the sink are deployed in the network area.
- Figure24 : Launch the simulation.
- Figure25 : static network stability.
- Figure26 : Multiple Sink Node.
- Figure27 : Example of delivery ration.
- Figure28 : Example of Energy Consumption.
- Figure29 : Example of Packet Delivery Ratio in multiple sink.
- Figure30 : Example of Energy Consumption in multiple sink.

Tables List

Table 1 : Various medical sensors deployed on the human body.

Table 2 : Difference between WSNs and WBANs.

Table 3 : Temperature aware routing protocols in body area network.

Table 4 : Qos routing protocols in body area networks.

Table 5 : Cluster-based routing protocol.

Table 6 : Postural-movement-based routing protocols.

Table 7 : Cross-layered routing protocols.

Table 8 : Simulation Paramet

Abbreviation

Abbreviations

A/N	Analog digital
ALTR	Adaptive Least Temperature Routing.
BS	Body sensor
BP	Blood pressure
DAO	Dude Arguing Online
DIO	Digital Input/Output
DMQOS	Data Centric Multi Objectives QoS.
EEG	Electroencephalogram
EMG	Electromyography
ECG	Electrocardiogram
ETPA	Energy efficient thermal and power aware routing.
ETX	Expected Transfer
E	Electric Field.
FDD	Full Functional Devices
HPR	Hotspot Preventing Routing.
HC	Hop count
IEEE	Institute of Electrical and Electronics Engineers
ID	Identity.
Ipv6	Internet Protocol version 6
IAP	Interfaces for Application Programming.
LEDs	Light Emitting Diode
LTR	Least temperature Routing.
LOS	Line of Sight.

LOCALMOR	Localized Multi Objectives Routing.
M-ATTEMPT	Mobility Supporting Adaptive Threshold-Based Thermal-Aware Energy-Efficient Multi-hop protocol.
MAC	Medium access control.
NLOS	Non-Line Of Sight.
ODS	Ordinary Data Packets.
OBSFR	On-body store and flood routing
PLC	Programmable Logic Controller.
QOS	Quality of service.
RAIN	Routing algorithm for networks of homogenous and Id-less biomedical sensor nodes.
RPL	Routing Protocol for Low-Power and Lossy Networks
RSSI	Received Signal Strength Indicator.
RF	Radio frequency
SHA	Shortest Hop Algorithm.
SSSP	Single Source Shortest Path.
SAR	Specific Absorption Rate.
TARA	Thermal Aware Routing Algorithm.
TIP	Temperature Increase Potential.
TSHR	The Thermal-Aware Shortest Hop Routing.
TDMA	Time Division Multiple Access.
TICOSS	Time zone Coordinated Sleeping Scheduling.
WBANs	Wireless body area networks.
WSNs	Wireless sensor networks
WASP	Wireless Autonomous Spanning Tree Protocol.
W/KG	Watts per kilogram.
Σ	Conductivity.
6LOWPAN	IPv6 over Low-Power Wireless Personal Area Networks

General Introduction

General introduction

In recent decades, rising life expectancy in many parts of the world has led to an increase in the elderly population. The United Nations predicts that by 2050, there will be 2 billion older persons in the world (22%). Cardiovascular diseases are the leading causes of death worldwide, accounting for 30% of all deaths. According to statistics, heart disease kills nearly 17.5 million people worldwide every year. Moreover, about 246 million people suffer from diabetes. By 2025, 380 million people will lack adequate healthcare conditions. Availability of healthcare can reduce a number of diseases such as Parkinson's disease, kidney problems, Alzheimer's disease, etc. In addition, the outbreak of epidemic diseases such as COVID-19 has existed since 2019 and has claimed many lives in the world. In the first year of this pandemic, many hospitals and health centers were occupied, while many people avoided going to these places for other essential treatments. In such a situation, the importance of joining WBANs and the Internet of Things becomes even more important. With this harmonic system, treatment and control [1].

However, creating a WBAN is a very delicate task that comes with many difficulties, from developing small and light mobile devices to avoid interfering excessively with patients' lifestyle and especially without endangering their health to ensuring the safety of their operations. This is done by ensuring secure and efficient communication with respect to: power consumption of nodes, support for node dynamics generated by patient mobility, etc. Routing protocols are responsible for providing all of this.

Many routing protocols have been proposed for WBANs, and these protocols have been categorized into five categories which: QoS-aware routing protocols, cluster-based routing protocol, cross-layer (multi-layer), postural-movement-based routing protocols, temperature routing protocols, implementing these protocols is not an easy task.

This dissertation is organized into three chapters dealing with relevant topics. After the general introduction, Chapter 1 introduces Body Sensor Networks (WBANs), and we give a general outline of WBANs, their architectures, application areas, topologies, and the communication technologies they use. Chapter two is devoted to previous work on routing in WBANs. We begin by classifying routing protocols for WBANs, then introduce the different classes of these protocols while citing the characteristics of the most well-known protocols for each class. Chapter 3 discusses the RPL protocol available for the Internet of

Things. Various IoT research ideas need to design the IoT protocol so that the detailed analysis of the Routing Protocol (RPL).

Knowing the findings, discussions, and conclusions in this chapter are important for improving our way of life. Finally, we will end our thesis with a general conclusion.

Chapter 1

Wireless body area network basics

Introduction

Technology has advanced dramatically in recent years. the microelectronics industry, which gave rise to novel, inexpensive, low-power small biological sensors. such sensor facilitated the development of a new class of wireless sensor networks known as WBANs (wireless body area networks). In this chapter, we give an overview of WBANs, and theirs Architecture and its application areas, topologies and technologies communication they use.

1. Definition of WBAN

Wireless Body Area Networks (WBAN): Are electronic gadgets that can be worn or implanted on or within the body to track a variety of physiological factors, including heart rate, blood pressure, body temperature, blood glucose levels, oxygen saturation, and brain activity. They are used to track performance and improvement in sports and fitness as well as in healthcare settings for disease diagnosis, treatment, and monitoring. Body sensors can deliver ongoing, real-time data, enhancing the precision of diagnosis and therapy and allowing for patient remote monitoring.

Wearable fitness trackers, glucose monitors for diabetes management, and electroencephalography (EEG) monitors for brain activity are a few examples of body sensors .Figure (1) shows the typical location of some sensors on the body human.

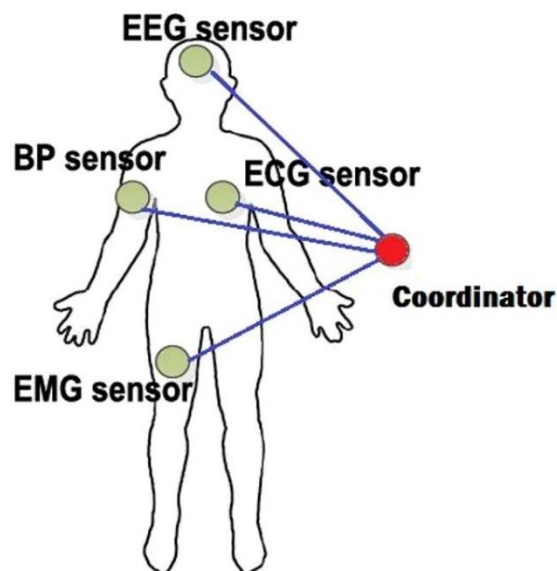

Figure 1:wireless body area network.

2. Sensor Node Architecture

In Figure (2), a typical sensor architecture is shown. The sensor consists of four basic components, each of which performs a specific task. Data processing units, data acquisition, data transmission, and battery.

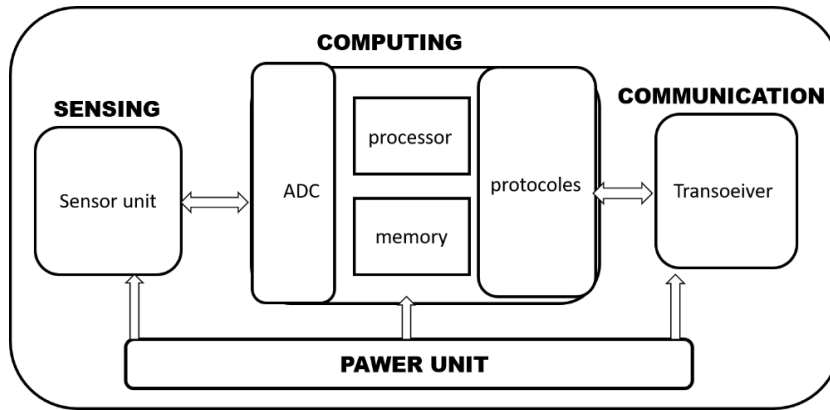

Figure2. sensor-node architecture.

The following table shows some body sensor functions.

Sensor	Description
ECG	The heart’s electrical activity
Blood flow	Measurement of accelerating forces in three-dimensional space of the body
Blood pressure	The force applied by the circulation of blood on the walls of the blood vessels
Body temperature	An indicator of the body’s ability to create and release heat
Oxygen level	Indicates the oxygen that is flowing in the patient’s blood
Heart rate	The frequency of the cardiac cycle
Blood sugar	Measures the amount of sugar (type, source, energy) in the blood
Muscle signal	The electrical activity of skeletal muscles (nervous, muscular system)
Electroencephalography	Measures automatic brain activity and other brain capacities

Table 1. Various medical sensors deployed on the human body [5.6].

3. Body sensor Network architecture

The design of body sensors can be categorized into three levels as shown in Figure (3).

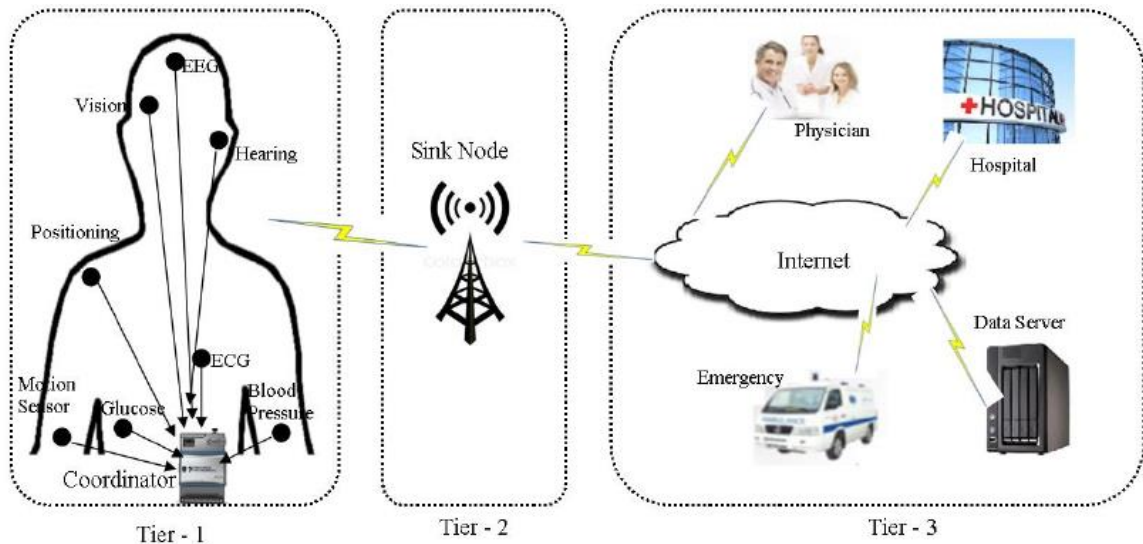

Figure 3. The architecture of wireless body sensor networks [2].

Tier-1 Medical sensor nodes are implanted on or in the human body along with the sink located at this level [2].

Tier- 2. Sensor nodes transmit the data to the sink, and the data are then transmitted to the BS by aggregating and processing the data [2].

Tier-3. After the data are received by the BS, they are transmitted to the medical center through the Internet infrastructure for remote monitoring and treatment. In general, in the architecture of this type of network, each sensor monitors the individual's health by receiving the sensory information from the patient's body, then sending the data to sink node before transfer to the BS to call for medical care [2].

4. WBAN network topologies

The star topology figure (4a) consists of a central node (trough) to which each WBAN node is connected. All data traffic passes through the central node; Therefore, a sufficiently strong central node is required. This architecture is easy to design, implement and extend. This is the most proposed and widely used structure for WBANs. The main disadvantage of this structure is the vulnerability of the central node, if it fails, then no connection is possible.

In terms of mesh topology figure (4b), nodes broadcast their own data and also act as relays to propagate data from other nodes. There are two types of network topologies: partially connected network, and some in its nodes are connected to more than one other node and the fully connected network, where each node is connected to all other nodes in the network. In general, WBANs use a partial grid. The advantage of this architecture is its flexibility and scalability. While the main disadvantage of this architecture is the latency created by passing messages through several nodes before reaching the destination node [4].

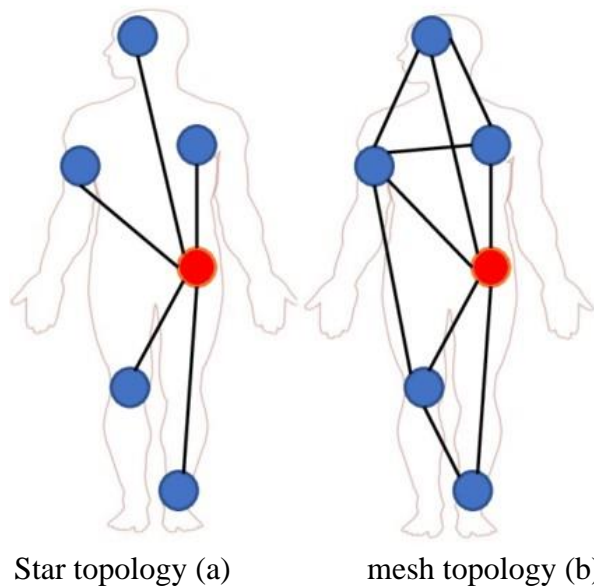

Figure 4. The structure of topology in WBAN.

5. WBAN communication technologies

WBAN is implemented using various short-range technologies ensuring the exchange of data between the different nodes of the network and the gateway, they are used in intra-WBAN communications. These technologies include among others Bluetooth, Bluetooth Low Energy, ZigBee and IEEE 802.15.6. Each of these technologies is short-range and has a variety of characteristics with respect to operating frequencies, network topology, throughput, and bandwidth, energy consumption. In this section, we focus on some short-range technologies that can be used in WBANs.

5.1 . Bluetooth

Bluetooth is a short-range technology, it works in the 2.4 GHz frequency band and the typical operating range is 10 to 100 m which makes it a possible choice to implement a WBAN. Bluetooth offers high data rates, it works on 79 channels of 1 MHz each. However, Bluetooth consumes a lot of power, so it is not ideal for WBAN applications. In addition, Bluetooth technology works like a star topology, where a master and seven slaves form the network. This limitation implies that only seven slaves can be active at a time, which puts a threshold on the maximum number of nodes to be used in the WBAN Network [3].

5.2. ZigBee

ZigBee technology is one of the widely used wireless network technologies adopted by applications that require low data rate and long battery life, which makes it widely used for WBAN applications. ZigBee supports a variable data rate ranging from 20 Kbps to 250 Kbps. It operates on 16 channels on the 2.4 GHz ISM band (250 Kbps), on 10 channels on the 915 MHz bands (40 Kbps) and on a single channel on the 868 MHz bands (20 Kbps) [3]. The major disadvantage of ZigBee for WBAN applications is due to interference with WLAN transmission, especially in the 2.4 GHz band, where many wireless systems operate. Another disadvantage is related to its low data rate, which makes it unsuitable for real-time WBAN applications, especially in health care.

6. Difference between WSNs and WBANs

WSNs	WBANs
Cover the environment	Cover the human body
Large number of nodes	Fewer sensor nodes
Multiple dedicated sensors	Single multitasking sensors
Low level security	High security
High power demand	Lower power availability
Solar, wind power	Thermal, piezoelectric energy
Wireless solutions available	Lower power wireless
Data loss less of an issue	Sensitive to data loss

Table 2. Difference between WSNs and WBANs.

7. WBAN Applications

WBAN has allowed it to invade many areas of application. In fact, we find WBANs ubiquitous in healthcare, the military, sports, and entertainment many other areas in which humans are involved.

7.1 . Medical Applications

With a wide range of potential applications, WBAN has dominated the medical industry. The effectiveness of doctor-patient interactions, including patient remote monitoring, timely health status updates, notification, emergency communication, etc., is improved by using WBAN technology.

7.2.Non-Medical Applications

7.2.1 Sports

Wearable WBAN-enabled devices are possible. Monitoring the physiological functions of the user, such as heart rate, temperature, respiration rate, blood pressure, activity, and posture of any athlete participating in sports, is highly useful. WBAN sensors may be used to measure navigation, time, and distance.

7.2.2 Military

There are many possibilities for using WBAN in the military. WBANs can be used on the battlefield to communicate between troops and relay information to

the base commander about their operations, useful for tracking a soldier's position, temperature, and hydration level while on the battlefield.

The uniform can be equipped with sensors including cameras, GPS, surveillance and RF sensors.

So WBAN can provide greater accuracy, survivability, and connectivity on any military mission.

8. WBAN Challenges and Implementation Problems

8.1. WBAN Challenges

As an evolving technology, there are many issues with WBAN that need to be addressed, both technically and ethically, such as privacy. Some of the most important technical challenges that need to be addressed are scope, power consumption, security, quality of service and placement.

- **Range:** WBAN range is limited, a few meters away from the object. Thus, a reliable wireless connection is made within or near the human body.[7]
- **Power Consumption:** WBAN requires constant power to operate properly, which requires a constant power supply.[8]
- **Security:** Due to the lack of power supply, it is difficult to add complex security mechanisms.[9]
- **Quality of Service:** One of the most important challenges in WBAN is improving the quality of service.[10]
- **Placement:** It is difficult to place many nodes in a limited space.[11]

8.2. Implementation Problems in WBAN

These sensors have the ability to communicate and send physiological messages to the human body with the lowest energy consumption. However, economic and technical barriers destroy the system necessary for reliable and effective WBAN decision-making. In this section, attempts are made to rely on a more detailed and effective investigation of the infrastructure problems of WBAN sensors during implementation on the patient's body [16].

8.2.1 Physical Problems

(a) Sensitivity of Sensors

Sensors implanted on the body in industrial environments that are always exposed to inflammable and flammable substances must have significant sensitivity so that they can react, when necessary, when the surrounding environment heats up and when the temperature of the human body rises. However, in such cases, intense human sweat and steam from the surrounding environment can have a destructive effect on the sensitivity of these types of sensors, which causes damage and inaccurate recording of vital body data. To solve this problem, it is recommended to utilize mechanisms and algorithms that have the ability to calibrate on time and quickly [17].

(b) Battery Charging and Maintaining Energy Consumption

In closed environments such as medical clinics that are not sufficiently exposed to direct sunlight, in cases that sensors are worn under clothing, or with people suffering from Alzheimer's and forgetfulness, charging the sensors can remain a potential problem. Using the natural heat of the patient's body and charging the batteries during the patient's movement can be feasible solutions [18].

(c) Body Data Collection Strategy

There are always concerns about the collection of vital information of the human body by sensors, which in some cases can cause wrong decisions after processing the physiological information. In some cases, the use of a sensor may not be efficient on its own for accurate and sensitive recording and conclusions. In such cases, integrating sensors for collecting and then processing can be more effective [19].

Conclusion

In this chapter, we have introduced wireless body sensor networks. After a general introduction to wireless body sensor networks, we talked about the structure of the body sensor network and the structure of WBAN, making a comparison between WBAN and WSN.

Finally, we identified the challenges and Implementation Problems faced by the proposed technology. In the next chapter we will discuss and classify the routing protocols used in WBANs.

Chapter2

Routing protocols for WBANs

Introduction

Communication in WBAN networks depends on the used routing protocol. Following the capture of the quantities to be measured, each node routes the packet in accordance with the established routing protocol, but creating a routing system for WBANs is a challenging undertaking because of issues including postural body motions, power consumption, network lifetime, etc. In this chapter we will present the classification of the routing protocols used in WBANs.

1. Classification of Routing Protocols in WBANs

During last decade, researchers have proposed different types of routing protocols. In this chapter, we provide a general overview of the existing routing protocols, which may be classified as QoS-aware routing protocols, temperature-aware routing protocols, cluster-based routing protocols, postural-movement-based routing protocols and cross-layered routing protocols [21].

1.1. Temperature-based Routing protocols

Wireless communication uses radio signals that produce magnetic and electrical fields. Electromagnetic fields cause human tissue to absorb radiation and experience temperature rises. Even with modest heating, some organs highly sensitive to temperature changes (e.g., lens cataract) may suffer thermal damage.

The continuous operation of sensor circuitry contributes to tissue temperature rise as well. SAR (Specific Absorption Rate, unit W/kg measures how much radiation energy is absorbed by a unit weight of tissue. In order to understand how radiation affects SAR, let us consider the following relationship:[22]

$$SAR = \frac{\sigma |E|^2}{\rho} \left(\frac{W}{Kg} \right) \quad (1)$$

where " σ " denotes the electrical conductivity of the tissue, " E " is the radiation-induced electric field, and " ρ " denotes the tissue density.

For the past ten years, numerous scientists and engineers have worked to find a solution to the issue of temperature rise and overheating. Reducing the temperature increase of the implanted WBANs nodes is the goal of all temperature-aware routing strategies for WBANs. We have covered the temperature-aware routing protocols for WBANs that were put forth over the past ten years in the sections that follow [21].

1.1.1. Thermal aware routing algorithm (TARA)

Thermal-aware routing algorithm, the first routing algorithm that takes temperature into account (TARA). The proposed algorithm tries to lessen the possibility of the body sensor implant's internal temperature rising. Hotspots are described by TARA as the overheated nodes, and data from these nodes is sent away during transmission. To determine a node's temperature rise based on SAR, the author developed the Temperature Increase Potential (TIP).

Each node monitors the communication of nearby nodes while data is being transmitted by counting packets see figure (5), measuring communication radiation, and calculating power usage to determine the nodes' current temperatures. When a node's temperature exceeds the predetermined threshold value, this algorithm does not include that node in data transmission. By using temperature as a metric, TARA ensures that all nodes in the network are distributed at the same temperature. Since the only metric is temperature, TARA must deal with problems including network lifetime, packet drop, and dependable transmission [23].

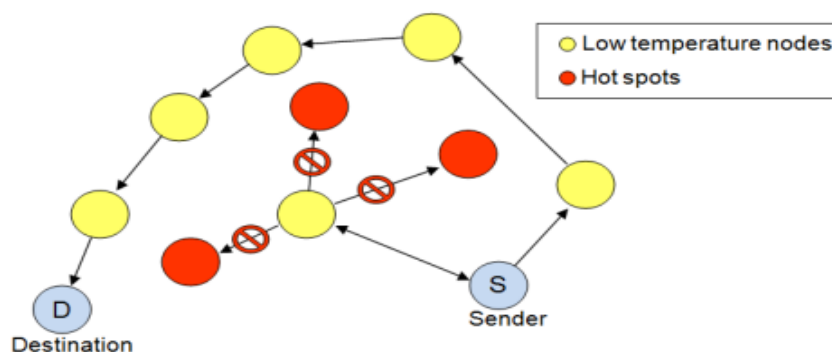

Figure 5. An example of TARA [24]

1.1.2. Least temperature routing (LTR)

To decrease the amount of heat created in body sensor networks, power consumption, and end-to-end latency, a thermal-aware routing protocol called least temperature increases was developed. By examining their communication activity, the researchers presume that each node knows the temperature information of its adjacent nodes. This technique chooses the node with the lowest temperature until the destination is reached as the next-hop node. Unlike TARA, which delays data packets if the destination is a hotspot node, it transmits the packet immediately to the destination node, as shown in the figure (5).

Each packet is assigned a hop-count, which is increased by one each time a node passes it. A packet is discarded if it exceeds the threshold value (MAX HOPS), which is determined by the network's width. In addition to the hop count, each packet maintains track of the nodes it passes through to avoid looping. Figure (6) depicts an illustration of how LTR works [25].

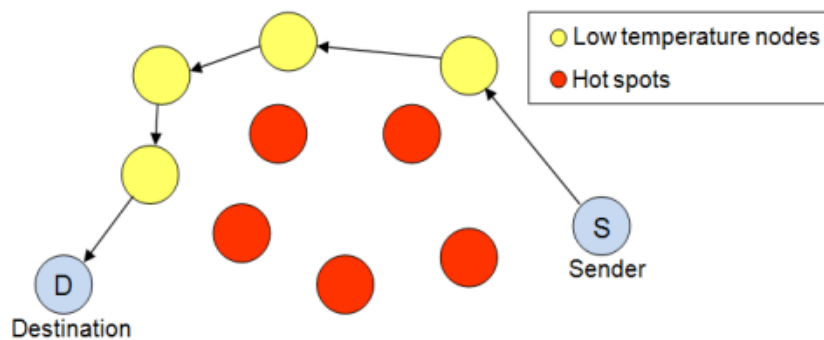

Figure 6. An example of LTR [24]

1.1.3. ALTR (adaptive least temperature routing)

The adaptive least temperature routing (ALTR) protocol solves the difficulty that LTR had. ALTR's method is similar to LTR's, with the exception that MAX HOP is replaced with MAX HOP ADAPTIVE. Instead of dropping the packet when it exceeds the MAX HOP ADAPTIVE threshold, ALTR uses the Shortest Hop Algorithm (SHA) to send it to the destination, as shown in the figure (7) [26].

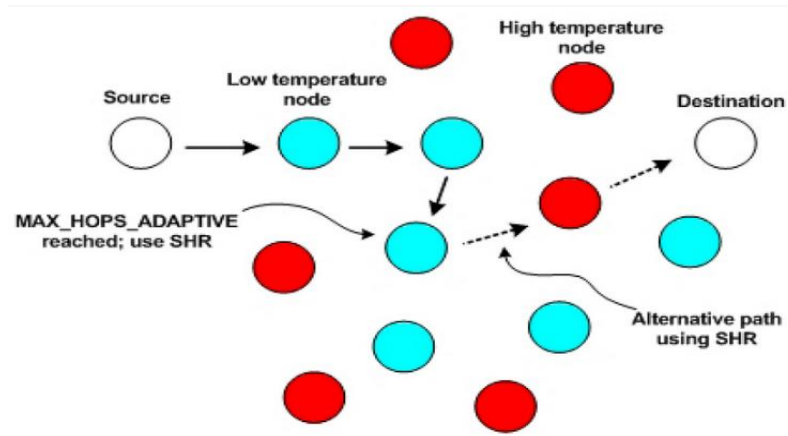

Figure 7. An example of ALTR [21]

1.1.4. LTRT (least total-route temperature)

The authors suggested a thermally sensitive routing protocol called least total route temperature (LTRT), which was aimed to locate routes with the lowest temperature while also addressing the issue of superfluous hops. This protocol picks routes with the lowest total temperature from the source node to the destination node and also saves network capacity by reducing the hop count. Single Source Shortest Path (SSSP) graph theory techniques, see the figure (8) (for example, Dijkstra's Algorithm) is used to determine the route with the lowest total temperature and then employ these routes for data connection. This approach observes neighbor node communication events to acquire temperature information and assigns the estimated temperature of each node as that node's weight. The following actions can help you accomplish your LTRT goal [25].

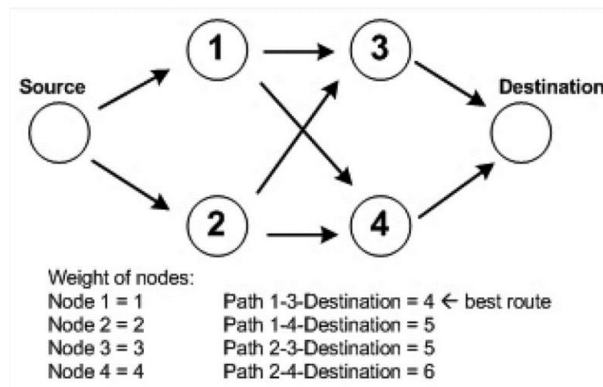

Figure 8. An example of LTRT [27]

1.1.5 HPR (hotspot preventing routing)

Hotspot preventing routing (HPR) is a routing protocol designed for time-critical biomedical applications such as medical monitoring. It seeks to reduce average packet latency and avoid the establishment of hot spots. Unless hotspots exist, HPR sends packets through the best nodes from the sender node to the destination with the fewest hops. If the number of hops exceeds MAX SAUT, the packet is rejected.

Packets also maintain a list of most recently visited nodes to avoid loops. The temperature change of neighboring nodes is calculated through the number of neighbor transmissions and the estimation of the number of packets transmitted in a certain time interval [25].

1.1.6 Routing algorithm for networks of homogenous and Id-less biomedical sensor nodes (RAIN)

Routing algorithm for networks of homogenous and Id-less biomedical sensor nodes (RAIN) is a routing protocol aimed at lowering the average temperature increase and power consumption of WBANs nodes, and a fault-tolerant that works efficiently even if some of its nodes fail due to energy exhaustion. RAIN is divided into three phases: setup, routing, and status update. The phrase ID-less does not imply that the sensor nodes never utilize IDs. RAIN employs transient Identifiers rather than static global IDs. These temporary IDs are created at random during the setup phase and are valid for the duration of the operation. The sink node has the ID 'zero' designated for it. Via hello packets, all nodes, including the sink node, announce their Identities [29].

1.1.7. TSHR (thermal-aware shortest hop routing)

The Thermal-aware shortest hop routing (TSHR) has been presented for the application where sending a packet to the destination is of high priority, and if the packet is dropped, it is retransmitted.

The TSHR algorithm is divided into two stages:

- 1) The setup phase, during which each node generates its routing table.
- 2) the routing phase, during which nodes attempt to route packets to the destination using the quickest path [29].

1.1.8. A new energy-efficient routing protocol (M-ATTEMPT)

A new energy-efficient routing protocol (M-ATTEMPT) is an energy-efficient and thermally sensitive routing algorithm for WBANs that uses heterogeneous bio-medical sensor nodes to reduce node temperature and latency for crucial data. The sink node (base station) is located in the core of the network architecture of this scheme, whereas nodes with high data rates are located in less mobile areas of the human body.

For important or query-driven data packets, sensor nodes raise their transmission strength to deliver the data packets straight to the sink node (single-hop), but multi-hop communication is employed for routine data packets. If two or more routes are available for multi-hop communication, the route with the fewest hops is chosen. If two or more next-hop neighbor nodes have the same hop-count, the node with the lowest energy consumption to the sink is chosen.

M-ATTEMPT establishes a temperature threshold to regulate the rise in temperature, and if any node's temperature exceeds that level, it breaks all routes with the neighbor node [30].

After presenting the temperature routing protocol class, the table [3] summarize the studied protocols.

CHAPTER 2 : Routing protocols for WBANs

Protocol	Goal	Temp. Rise	Delay	Energy Cons
TARA [23]	To reduce the possibility of overheating	Very High	Very High	Very High
LTR [25]	To reduce the temp rise and energy consumption	High	High	High
ALTR [26]	To reduce the temp rise, energy consumption and end-to-end delay	Low	Medium	High
LTRT [25]	To find routes with minimum temperature	Very Low	Low	Low
HPR [28]	To prevent the formation of hotspots and reduce end-to-end average delay	Very Low	Low	High
RAIN [29]	To reduce average temp rise and average delay	Very Low	Low	Low
TSHR [29]	To reduce temp rise, energy consumption and delay	Very Low	Medium	Low
M-ATTEMPT [30]	To reduce temp rise, energy consumption and delay	Low	Low	Low

Table 3: temperature aware routing protocols in body area network [21].

1.2.QoS-aware routing protocols

The QoS-aware routing protocols are modular-based and employ several modules for various QoS metrics. The coordination between these modules and the intricacy of taking into account various modules for various QoS metrics make the design of these protocols a difficult task. The next sections explore few QoS-aware routing methods for WBANs [21].

1.2.1.Routing service framework

In order to provide diverse QoS support and routing service according to priority in the network, Liang and colleagues suggested a QoS-based routing protocol for sensor networks in the biomedical field. The following actions are taken to implement this protocol [28]:

Establishing and maintaining QoS-based routes

- Arrangement of packet routing priorities.
- User application input on network status.
- Traffic balancing on networks.
- Interfaces for Application Programming (IAP).

1.2.2.New QoS and geographic routing (LOCALMOR)

The localized multi objectives routing protocol (LOCALMOR) are routing protocol for biomedical applications in WBANs was put out. Depending on the needed QoS metric for the multi-objective problem, such as dependability, latency, throughput, or residual energy in the sensor nodes, it divides the data flow into several categories. Where several methods and route specifications are offered for each category. Additionally, because an acknowledgment mechanism is employed, the suggested protocol may be used with any MAC protocol, as in the figure (9) [28].

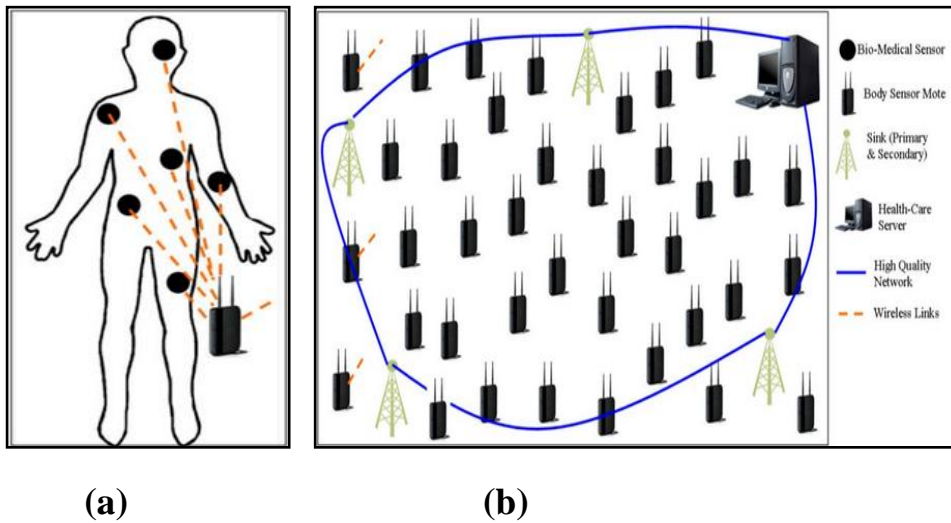

Figure 9. System architecture of LOCALMOR, (a) On-body network, (b) In-hospital network [31].

1.2.3. Data-centric multi-objectives QoS-aware routing (DMQoS)

The goal of the multi-objective, module-based DMQoS routing protocol is to satisfy the QoS criteria of many categories of produced data. Ordinary data packets (ODs), reliability-driven data packets (RPs), delay-driven data packets (DPs), and Critical Data Packets are the four classifications of data packets in DMQoS. receives the detected data from the bio-medical sensor nodes. Compared to bio-medical sensor nodes, the body sensor mote is a central node, and has less energy and compute capacity restrictions.

The DMQoS network design is depicted in figure (10). After the necessary data processing and aggregation, the body sensor mote sends the data via several body sensor mote hops in the direction of the sink [31].

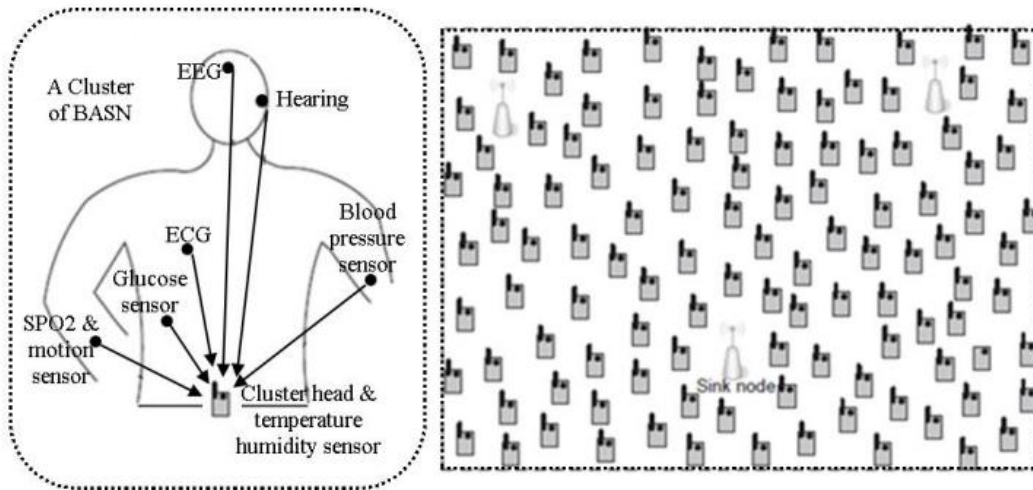

Figure 10. Network architecture for DMQoS [31].

After presenting the QoS-aware routing protocol class, the table [4] summarize the studied protocols.

Protocol	Goal	Network Size	Mobility	Delay	Energy Cons
Routing Service FW [28]	To provide priority-based routing & user specific QoS Support	Small	Yes	N/A	N/A
LOCALM OR [28]	To provide QoS support based on nature of Data	Medium	Yes	Low	High
DM QoS [28]	To provide Data Centric QoS support	Large	Yes	Low	Medium

Table 4: Qos routing protocols in body area networks [21].

1.3. Cluster-based routing protocols

The technique used in cluster-based routing is taken from WSNs, several tests have shown that the clustering approach is more suited for WBANs than the LEACH (Low Energy Adaptive Clustering Hierarchy) protocol, which is a classic work in the WBANs.

The clustering approach can guarantee network connection, balance network core and edge power consumption, adapt to dynamic structure, and improve network robustness as the number of nodes and the relative distance between nodes both grow [32].

1.3.1. Hybrid indirect transmission (HIT)

Hybrid indirect transmission (HIT) is based on a hybrid architecture that consists of one or more clusters, each of which is based on multiple, multi-hop indirect transmissions. In order to minimize both energy consumption and network delay, parallel transmissions are used both among multiple clusters and within a cluster. This is made possible by having each sensor independently compute a medium access controlling TDMA schedule [33].

1.3.2. Any body

The five phases that Any Body: A node first determines which other nodes it may directly connect with by exchanging hello messages with its 1-hop neighbors (step 1), nodes are then organized into clusters using this data, with one cluster leader for each cluster (step 2 and 3). In step 4, clusters are joined, and routing pathways are established for the sink node, as in the figure (11) [34].

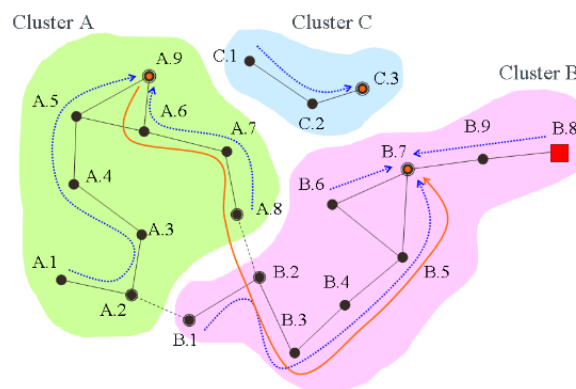

Figure 11. Hierarchical structure of cluster-based routing [34].

After presenting the Cluster-Based routing protocol class, the table [5] summarize the studied protocols.

Protocol	Goal	Metrics	Avg. Delay	Security	Energy Cons
HIT [33]	To maximize the network life and reduce the direct transmissions to the sink	Geographic information & residual energy of the nodes	Low	Yes	Low
Any Body [34]	To reduce the direct transmission of the nodes to the sink node	Nodes density	N/A	No	N/A

Table 5. Cluster- based routing protocol [21].

1.4. Postural-movement-based routing protocols

Body movements, link failure, and environmental obstacles all have an impact on the topology of the network, causing linkages to disconnect.

This problem has been studied extensively, and a cost function has been developed to determine the most effective way to send packets to the sink on a regular basis.

The following is a list of a few protocols that fit under this category [35].

1.4.1. On-body store and flood routing (OBSFR)

On-body store and flood routing (OBSFR) are proposed on-body packet routing technique for wireless body area networks (WBANs) that provides improved routing time and hop count. The proposed protocol employs an opportunistic forwarding strategy depending on node distance from the on-body sink node, see the figure (12). Furthermore, the end-to-end packet delay, number of packets per transmission, and packet delivery ratio are checked and compared to existing routing protocols [35].

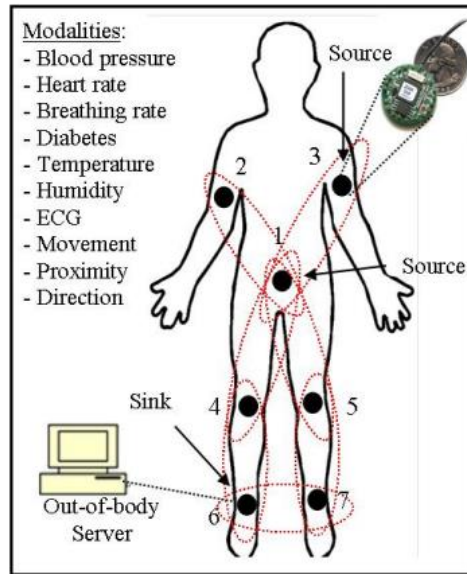

Figure 12: Network Architecture of OBSFR [35].

1.4.2. Opportunistic routing

An opportunistic routing is proposed to overcome this body movement problem. Actually, the idea of this protocol is simple, it is how to transmit data in LOS (Line of Sight) condition as long as possible. The idea could be realized by using a relay node located at a right place. In this proposal, it is assumed that the sink node is located on wrist and a sensor node is placed on chest. While the person is walking, his hand will go back and forth so sometimes the sensor node will transmit a LOS signal (when the wrist is in front of the body), while at other times, the signal is a NLOS (when the wrist is behind the body).

When the hand node is in LOS position, the sensor node will transmit the data directly to sink node, while when the hand node is in NLOS position, the sensor node will make use of relay node - which is in LOS position to both sink and sensor node - to send data to the sink node. The sensor node will opportunistically use the relay node to be able to transmit data in LOS condition as long as possible [36].

1.4.3. Energy efficient thermal and power aware routing (ETPA)

Authors proposed an energy efficient thermal and power aware routing protocol (ETPA), based on the posture-movement of the human body. ETPA aims to decrease the temperature rise and power consumption. ETPA uses the same network architecture used by PRPLC.

In this protocol the frames are divided into time slots using a Time Division Multiple Access (TDMA) scheme, where each node transmits in its own time slot. During each cycle (after every four frames), all nodes broadcast their hello messages to their neighbors containing the temperature and residual energy and then every node estimates the received power from neighbors nodes.

ETPA uses temperature, residual energy and transmission power of the node to calculate the cost function. When a node has a packet to send, it searches for an efficient route with minimum cost. If it finds nodes with an efficient route, it forwards the packet, otherwise it buffers the packet. A packet is dropped if it has been buffered for more than two frames. In order to decrease the delay, each packet can only pass through a pre-defined number of hops (max_hop_count), otherwise it will be dropped [37].

After presenting the Postural-movement-based routing protocol class, the table [6] summarize the studied protocols.

Protocol	Goal	Mobility	Metrics	Avg. Delay	Energy. Cons
OBSFR [36]	To decrease end-to-end delay and hop-count	Yes	Link Quality	1.88 s	High
Opportunistic [37]	To increase the life time of the network	Yes	LoS & NLoS Comm	N/A	Very Low
ETPA [38]	To reduce the temperature, rise & energy consumption	Yes	Link quality & nodes temp.	High	Low

Table 6. Postural-movement-based routing protocols [21].

1.5. Cross-layered routing protocols

The cross-layered routing protocols are the final group of WBANs routing protocols covered in this search. In order to enhance the network's overall performance, these protocols simultaneously address and attempt to resolve the

problems and challenges of the network and MAC levels. In the sections that follow, we've covered a few of the most significant cross-layered routing methods [21].

1.5.1. Wireless autonomous spanning tree protocol (WASP)

Wireless autonomous spanning tree protocol (WASP) is defined to achieve low delay and increased network reliability for WBANs. In WASP scheme a message is disseminated to update parent nodes with information of its child nodes. However, power balancing issue is not discussed. Authors applied tree algorithm with prioritization for WBANs, as shown in the figure (13). Where, a channel is dedicated for emergency data delivery and normal data transmission is lagged until the successful delivery of critical data. However, the dedicated channel results in loss of available resources [30].

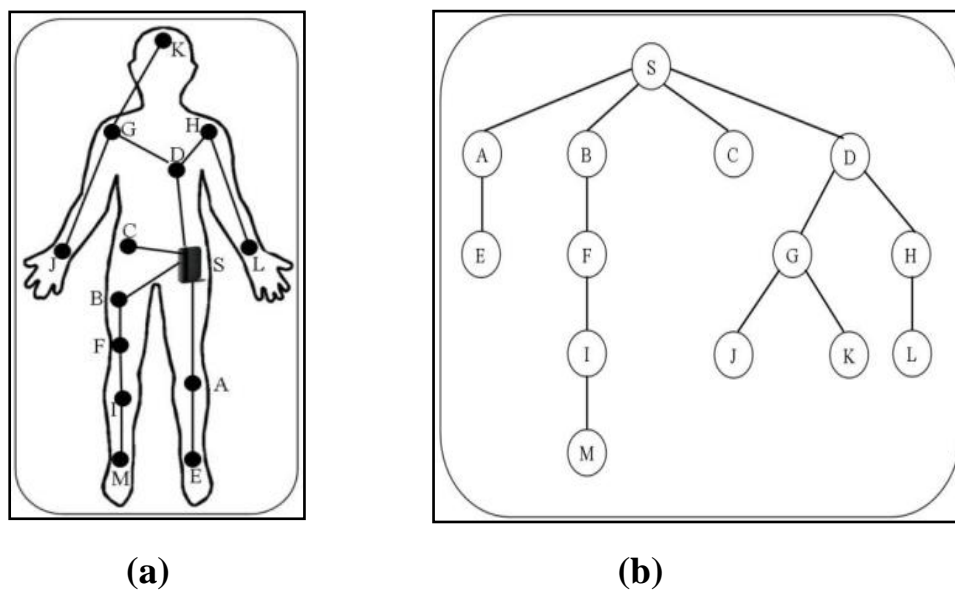

Figure 13. (a) Network on the body (b) Abstract view of the network [38].

1.5.2. Time zone coordinated sleeping scheduling (TICOSS)

By configuring the shortest path route to the WBAN coordinator, conserving energy, and reducing hidden terminal collisions through V-scheduling (due to V-shape communication flow), Time zone Coordinated Sleeping Mechanism (TICOSS) adjusts all nodes as Full Functional Devices (FDD) and enhances the IEEE 802.15.4 standard, doubling its operational lifetime for high traffic scenarios and extending IEEE 802.15.4 to support mobility [39].

1.5.3. BIOCOMM

Another cross-layer routing protocol for WBANs called BIOCOMM was created based on how the MAC and network layers interact to improve overall network performance. A distributed spanning-tree based method called "adaptive multi hop tree-based routing" (AMR) has been developed. It takes into account the battery level, the Received Signal Strength Indicator (RSSI), and the number of hops.

AMR extends network longevity and maximizes the number of transmissions per delivered packet by balancing energy consumption across nodes [40].

After presenting the Cross-layered routing protocol class, the table [7] summarize the studied protocols.

Protocol	Goal	Mobility	Metrics	Avg. Delay	Energy Cons
WASP [30]	To decrease PLR, energy consumption, & end-to-end delay	No	Hop count and routing	324 milli-seconds	Medium
TICOSS [39]	To improve IEEE 802.15.4 standard	Yes	Hop count and routing	N/A	Low
Bio-comm [40]	To optimize the overall performance of the network	No	Node temp, hop count, and delay	Medium	Medium

Table 7. Cross-layered routing protocols [21].

Here we have summarized the routing protocols in a diagram as shown in the figure (14).

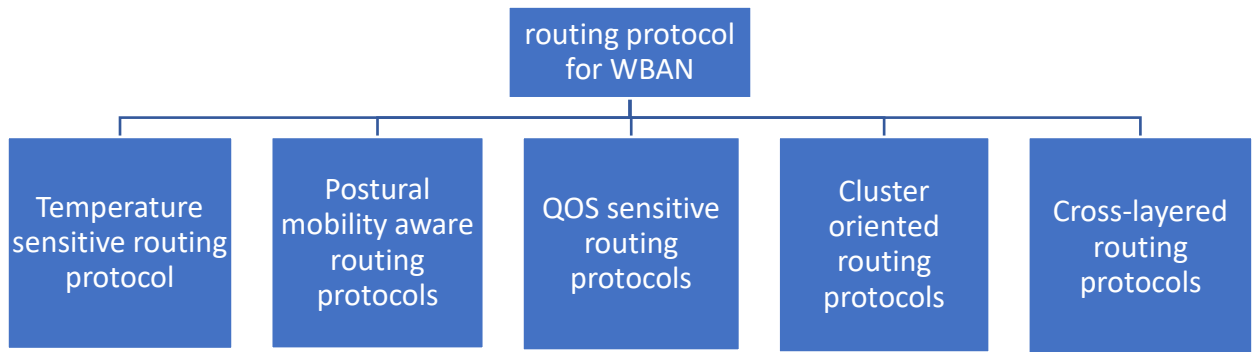

Figure 14: Categories of WBAN routing protocols.

Conclusion

We have tried through this chapter to provide a classification of routing protocols in WBAN networks and highlighting the work and purpose of each protocol.

In the next Chapter, we will implement RPL a routing protocol in application Contiki Cooja and Presentation of the results of evaluating the performance of the studied protocol.

Chapter 3

WBANs Implementatio

Introduction

After seeing the previous chapter concerning the classification of routing protocols .Implementing new algorithms or protocols for real networks is not an easy task. Therefore, developers and researchers use different simulation tools. In this chapter, we will use the cooja simulator dedicated to the Internet of Things and its descriptive studies, and from there we present the result of evaluating the performance of the studied protocol from: average power consumption , node information, network graph, etc...

1. Working environment and tools

we give a brief presentation of the ContikiOS operating system and its Cooja network emulator used to perform our simulations.

1.1.VMWARE workstation

VMware workstation is a line of desktop hypervisor products which lets users run virtual machines, containers and kubernetes cluste, the following figure represents it,see the figure (15) [41].

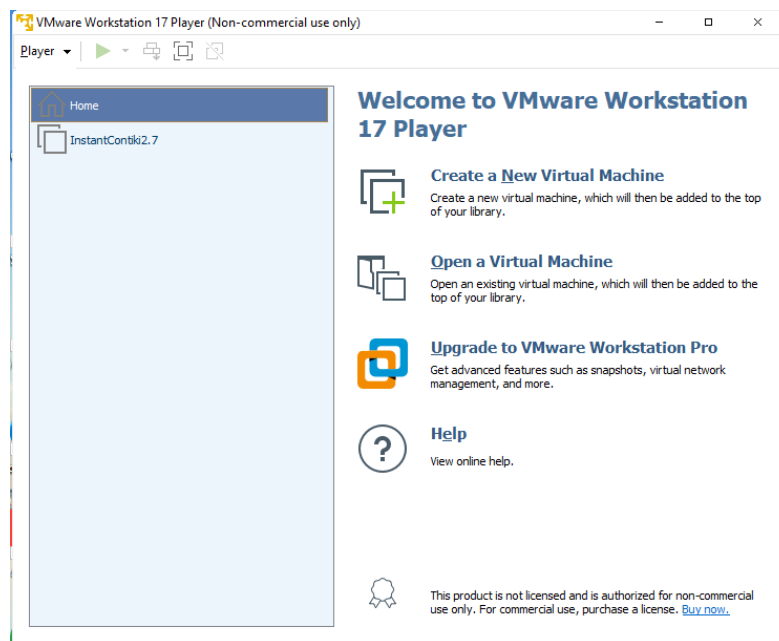

Figure15: VMWare Workstation 17 Player.

1.1.1. What is the VMware used for?

Although the VMware platform creates virtual machines and cloud computing solutions, it can be used for several applications. Key benefits include enabling seamless scalability, network flexibility, automated operations, remote workforces, and better security all of which businesses can use to cut costs [41].

1.1.2 What does VMware work?

In simple terms, it takes a single computer and creates multiple virtual computers that share the original's resources.

Imagine that your desktop Windows PC uses VMware on a single home-user basis. You could operate two or three other Windows environments, which function like two or three separate PCs. The only difference is that they're reliant on the underlying hardware of the original physical system [41].

1.2. CONTIKI

Contiki is an open source, light, flexible and generic system based on a hybrid operating model. This system was developed by a group of developers from industry and academia by Adam Dunkels of the Swedish Institute of Computing in 2002. Intended to be embedded in miniature sensors usually with limited resources, Contiki has presented the idea of using IP communication in low-power sensor networks. In addition, it supports the IPV6 and 6LOWPAN protocols, which is particularly useful insofar as the nodes communicate in IPV6 and use the 802.15.4 standard defined by the IEEE. Contiki contains two communications stacks : uIP and Rime.

uIP is a small TCP/IP stack that allows Contiki to communicate over the internet. Rime is a light weight communication stack designed for low power radios.

It provides a wide range of primitive communications.

Cooja is a simulator that come with Contiki [42].

2. working stages

2.1.Installing Contiki 2.7

In this part, we will describe the installation steps of Contiki 2.7 on Ubuntu 12.04 LTS 64 bits.

- Download contiki 2.7 from the following link :
<https://sourceforge.net/projects/contiki/files/Instant%20Contiki/>
- Unzip the file in /home/user/contiki using the command `sudo unzip contiki-2.7.zip`.

2.2. Cooja

COOJA is the acronym for Contiki OS Java Simulator.

To develop programs within Contiki, the system provides a network simulator called Cooja. The software allows you to emulate nodes and load a compiled program. This is particularly useful for testing programs before putting them into the flash memory of real nodes, since the software simulates the running and memory conditions of the I MSP430. Data collected from the sink via its standard output can be saved to files or read by software which can then process and present the data to the user.

Cooja can be loaded using command “sudo ant run-bigmem”.A new simulation can be generated in Cooja window. Cooja window is occupied by the main simulating tools. The functionality of each tool is given below:

- Network-It defines the location of each node in the network. It visualizes the status of node, including LED's, mote IDs, addresses, log outputs etc, After some time this window . will occupy sensors information.
- Simulation Control- this panel is used to handle the simulation parameters such as: pause, start, load execution time and simulation speed. It means that the events can run faster than actual execution .
- Notes-this is a simple notepad for making notes of the simulation. Mote output-output of all the nodes is in one window. If required, separate window for each node in the simulation is also possible.
- Timeline-here messages and events such as channel variation, log output, LEDs changes are displayed [43].

3. How to create the IoT network scenario using cooja simulator

Step-1 :

- Go to contiki/tools/cooja in terminal.
- Then give command ant run.
- Go to File option select New Simulation.

as in the figure(16).

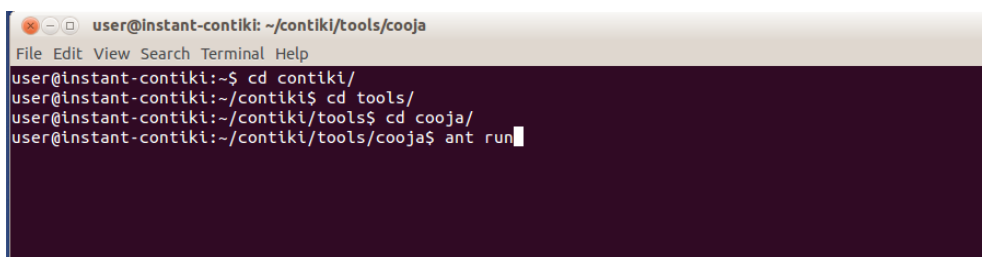

```
user@instant-contiki:~/contiki/tools/cooja
File Edit View Search Terminal Help
user@instant-contiki:~$ cd contiki/
user@instant-contiki:~/contiki$ cd tools/
user@instant-contiki:~/contiki/tools$ cd cooja/
user@instant-contiki:~/contiki/tools/cooja$ ant run
```

Figure 16: launch cooja from terminal.

Step-2 :

Create new simulation, as shown in the figure (17).

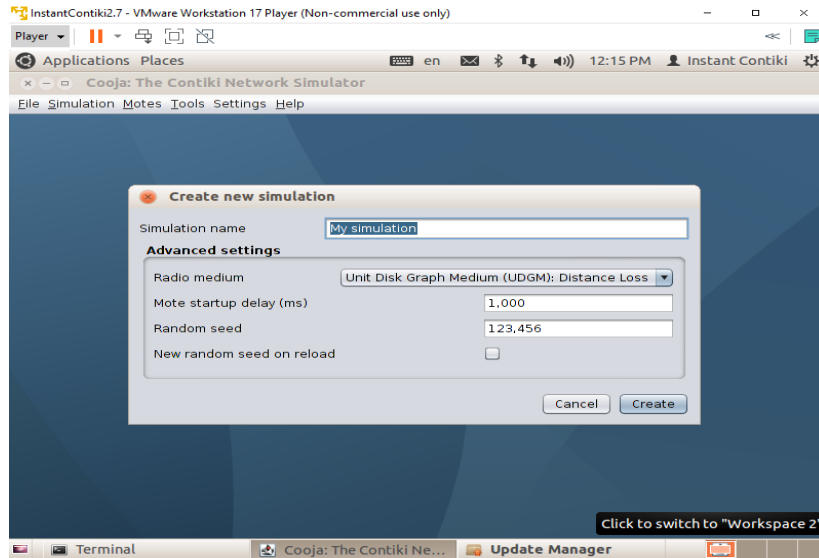

Figure 17: creation of a new simulation.

Step-3:

The network simulation is created, as in the figure(18).

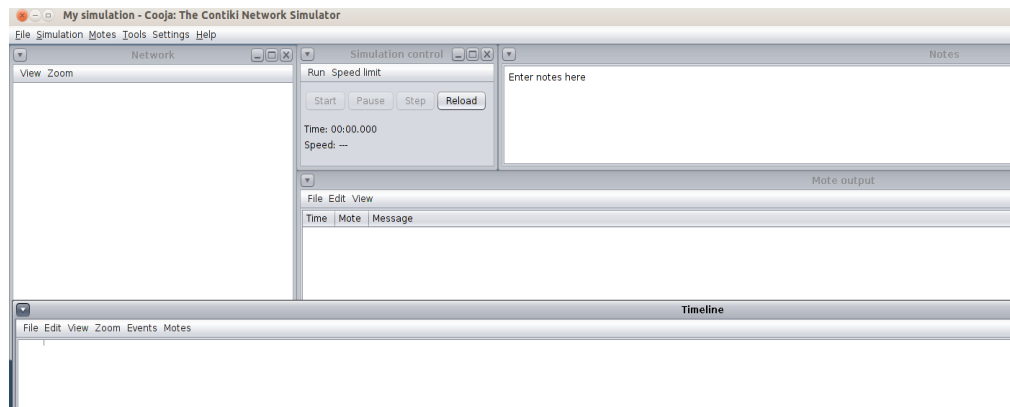

Figure 18: network simulation.

Step-4:

Then go to mote option select add motes and give create new mote type and select sky mote, as in the figure(19).

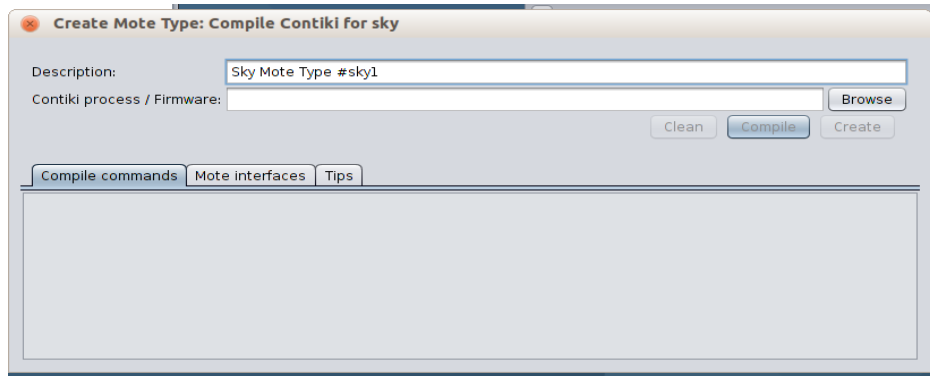

Figure 19 :create new mote.

Step-5:

Select any file for simulation then give clean and compile. Select create option, as in the figure(20).

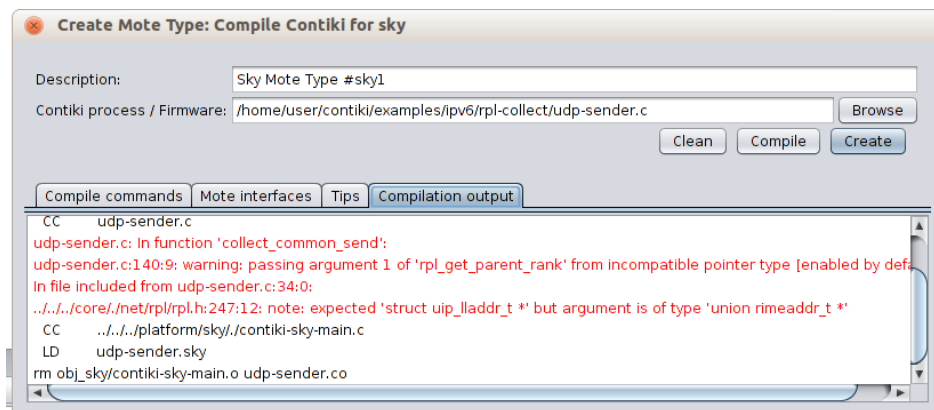

Figure 20: compilation terminated.

Step-6:

Now add motes and positioning, as in the figure(21).

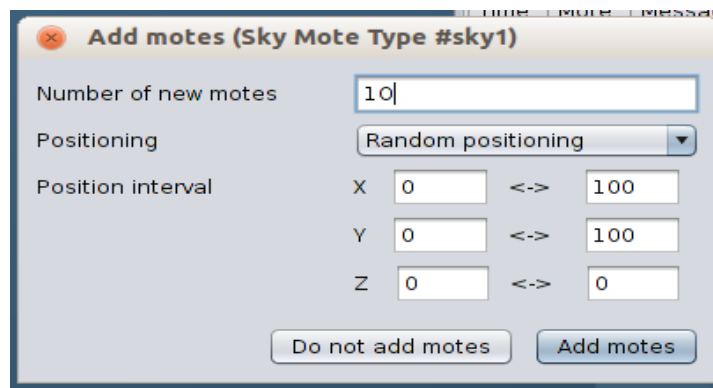

Figure 21: create motes.

Step-7:

Now the nodes are deployed in the network area, as shown in the figure (22).

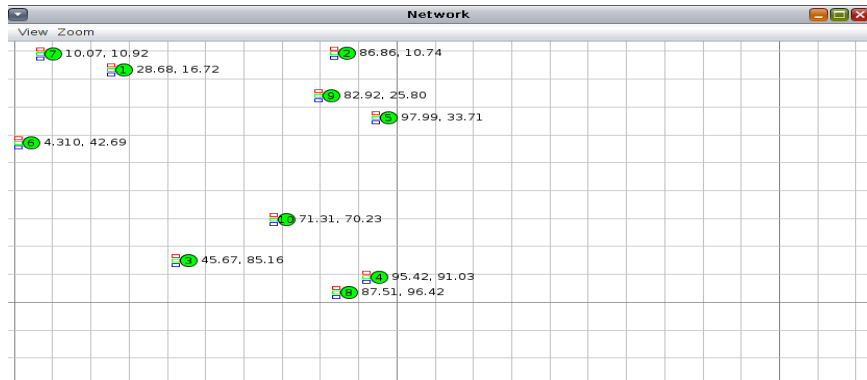

Figure 22: Node in the network area.

Step-8:

the sink are deployed in the network area, as in the figure(23).

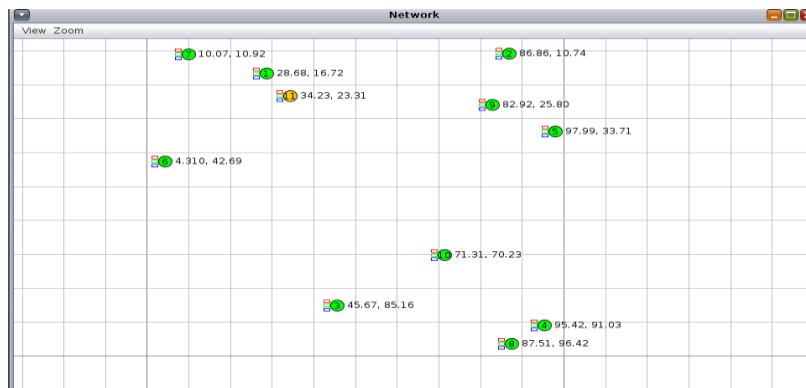

Figure 23 : the sink are deployed in the network area.

Finally launch the simulation with start, as shown in the figure(24).

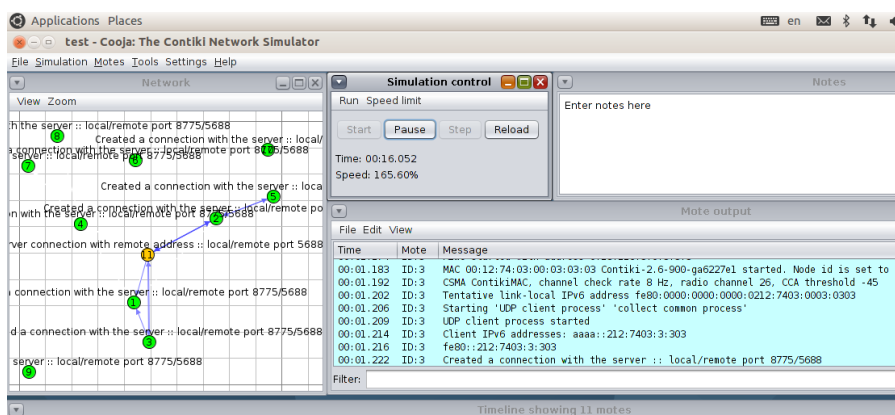

Figure 24: Launch the simulation.

4. Simulation and performance evaluation

This research analyzes the RPL protocol using the Contiki operating system and the Cooja emulator. This study is for the straightforward reason that researchers frequently use it to create real-time applications, and for a researcher to expand on their findings and create new applications, they need basic analysis information. Since simulations are event-driven, analyzing any scenario using them is more realistic.

4.1 RPL

RPL is a distant vector protocol designed for IPv6 lowpower devices, it operates on the IEEE 802.15.4 standard with the support of 6LoWPAN adaptation layer. This protocol creates a multi-hop hierarchical topology for nodes, where each node can send data to its parent node which in turn forwards it upward until it reaches the sink or gateway node. In the same way, the sink node can send a unicast message to target a specific node in its network.

RPL successfully and efficiently manages data routing for nodes that have restricted resources, it provides an operation framework that ensures bidirectional connectivity, robustness, reliability, flexibility and scalability. The key features of RPL come from its efficient hierarchy, the use of timers to minimise control messages and the flexibility of the objective function [44].

4.1.1.simulation parameters

Parameters	Value
OS	Contiki OS 2.7
Number of Nodes	7. 10. 15
Number of Sink	1 .2 .5.6
Node Transmission Range	20m
Node carrier sensing range	50m
Simulation duration	3min
MAC Layer	IEEE 802.15.4
Network protocol	ContikiRPL
Application program	Examples/ipv6/rpl-collect
Mote Type	Sky Mote
Network addressing	IP V6

Table 8: Simulation Parameters.

4.1.2.static network stability



Figure 25: static network stability.

- **ETX and HC**

The availability of neighbors was found to be justified by a cluster of 15 nodes, increasing ETX and HC, it was determined. Nodes can travel to their destination using HC. As packet transmission grows in a dense network, nodes are encouraged to send more packets. They thereby raise the possibility of packets being successfully received at the target. The increase in network density causes an increase in ETX.

- **Packet Delivery Ratio**

The simulation demonstrates that as the number of nodes rises, the packet ratio falls. This demonstrates RPL's superior performance in low-density networks in comparison to the supplied high packet ratio value. In contrast to low network density, which allows nodes with the same minimal rank to deliver data to various destinations, interference causes nodes to lose more packets. In this network can provide low link quality due to of density.

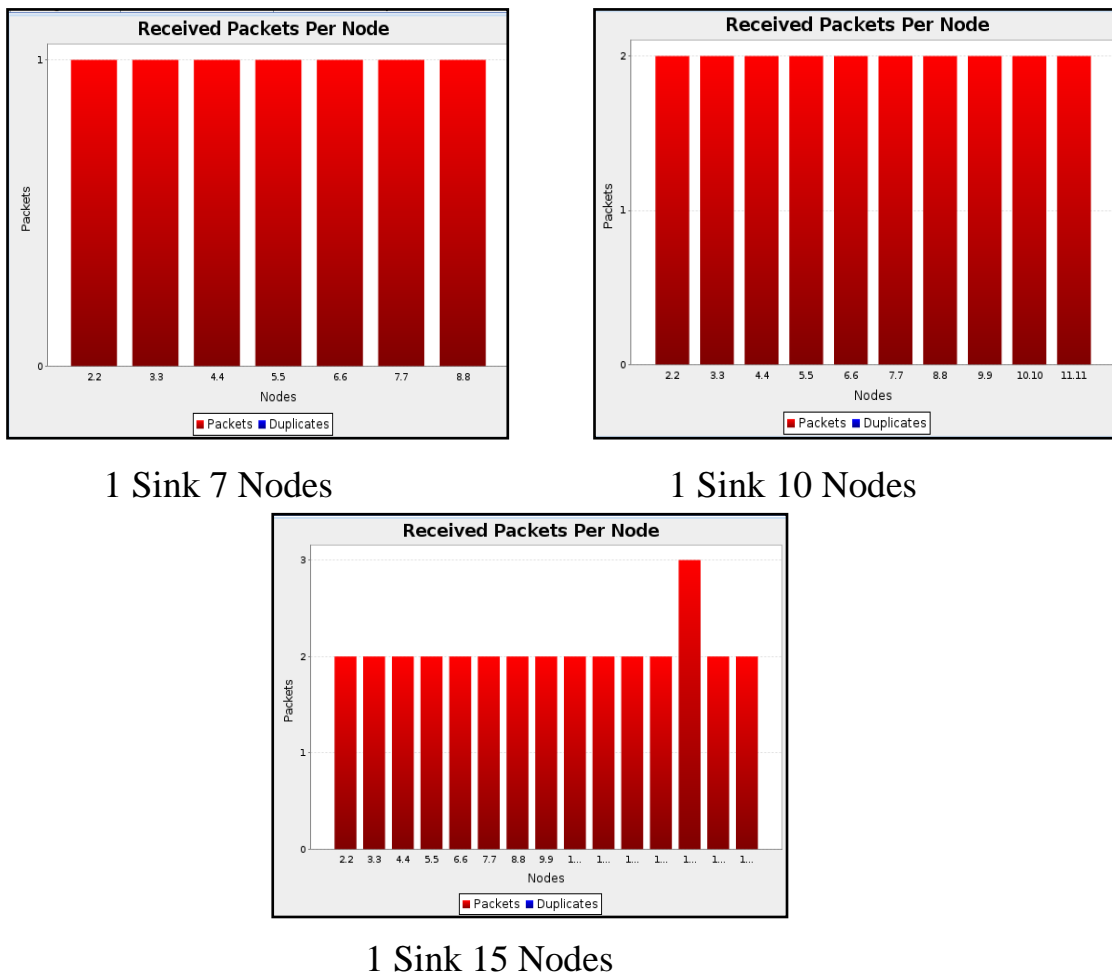

Figure27: Example of delivery ration.

- **Traffic Control overhead**

The nodes in a dense network provide the control message, which reduces the traffic management burden of the nodes in the low-density networks. In a high-density multicast network, nodes deliver more messages than they do spreading the routing table. While neighboring nodes continue to issue new DIO messages to update routing information, they transmit a DAO message in the routing tables. The importance of traffic control has increased with the increase in network density.

- **Energy Consumption**

We changed the network density to calculate the energy used. As the network got denser, it used more energy. The network grows as a result of nodes' transmission of packets. As the number of nodes rises from 7 to 15, more energy is used.

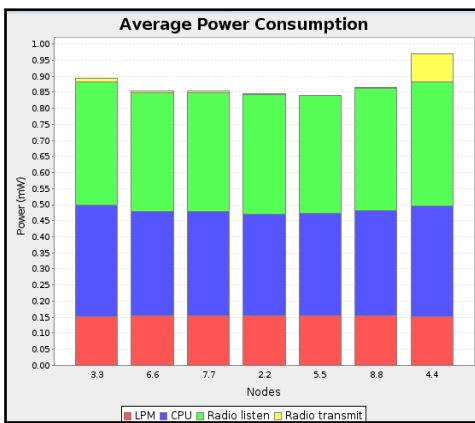

1 Sink 7 Nodes

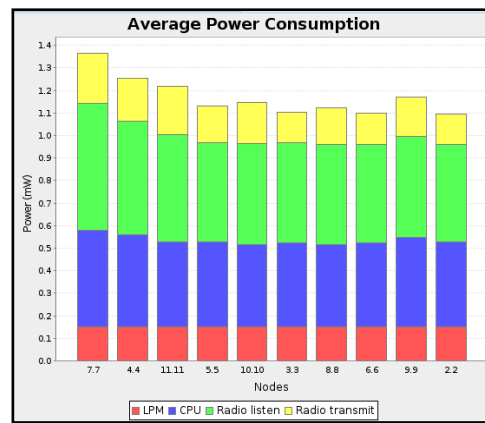

1 Sink 10 Nodes

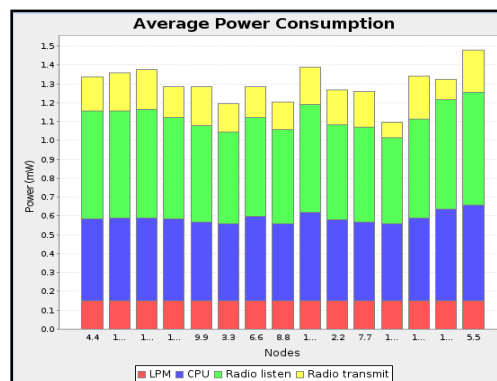

1 Sink 15 Nodes

Figure28: Example of Energy Consumption.

b. Multiple Sink

In this we consider the various metrics ETX and HC, packet delivery ratio, and energy consumption as per the multiple sink .

- **ETX and Hop Count**

As sink nodes grow, the hop count reduces. This shows that the sink node receives the data from the senders. Additionally, the sender node distributes the data to one or more sink nodes within the same transmission range. If they are far from the senders, some sink nodes won't be able to receive any data. The outcome demonstrates that sink nodes have a direct impact on lowering the ETX and Hop Count measures.

- **Packet Delivery Ratio**

According to the simulation results, the sink nodes have been raised while remaining the same as the sender nodes to calculate the packet loss ratio. When using fewer sink nodes, "RPL performance" suffers greatly. A small proportion of packets are lost during the data transmission from the sender to the closest sink due to the huge number of sink nodes.

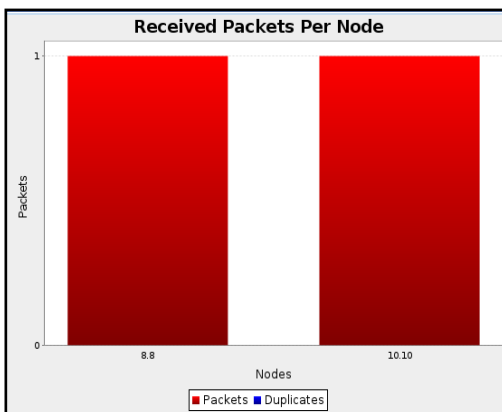

6 Sink 4 Nodes

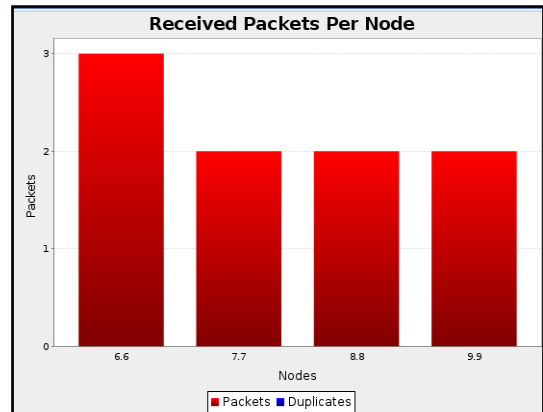

2 Sink 8 Nodes

Figure29: Example of Packet Delivery Ratio in multiple sink.

- **Traffic Control Overhead**

Since the traffic management overhead is significant, high value nodes provide traffic reduction. In addition, there are more sink nodes with fewer packets sent. Compared with a single-tub network, the basin with several troughs is more reliable. Redundancy and retransmissions by the sender are reduced thanks to the rank-based sink node.

- **Energy Consumption**

The ability to consume fewer resources is enabled by an increase in sink nodes. As a result, it can be demonstrated that as the number of sink nodes increases, energy

consumption from nodes 1 to 10 decreases. Because the sink node simply receives data from the sender and does not required to transmit the packet, it uses very little energy. To enable the sink node to send the first message, all nodes must be present. After that, sink nodes operate as a server and all sender nodes attempt to deliver their acquired data to them. Low energy usage is present in this situation.

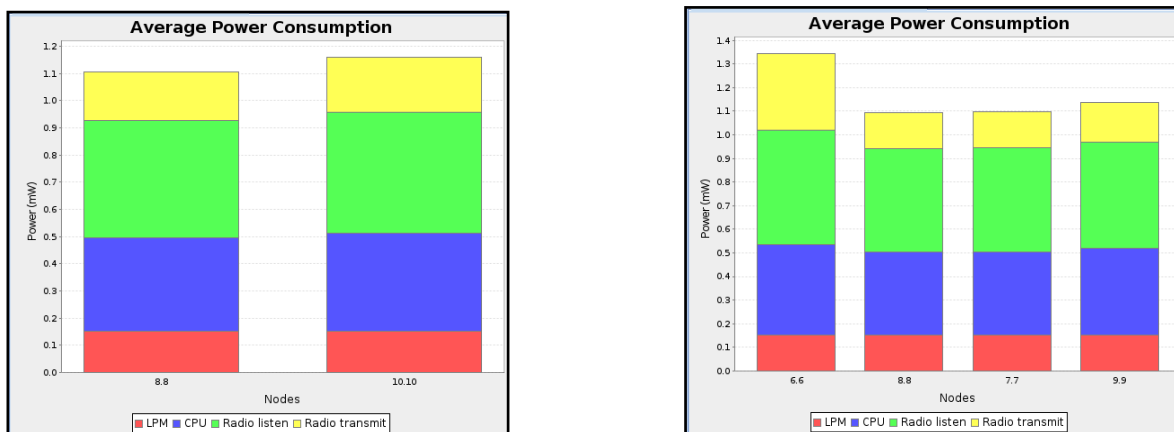

6 Sink 4 Nodes

2 Sink 8 Nodes

Figure30: Example of Energy Consumption in multiple sink.

After the implementation, we summarize the following:

- 1- The higher the number of nodes, the higher the power consumption.
- 2- Energy consumption decreases as the sinks increases.
- 3- The number of nodes increases and the percentage of packates increases.
- 4- A network with multiple sinks is more stable than a single sink.
- 5- The pelvic node receives only the proximal nodes.

Conclusion

The Internet of Things has emerged as the latest technology in a number of industries, including medical monitoring.

There are several protocols. In this chapter, we have examined the RPL protocol, which is used to transfer data from one node to another. and evaluation The behavior of the RPL protocol on fixed and multiple sink nodes .

General Conclusion

General Conclusion

The development of information and communication technology has reached a new stage represented by WBANs. Due to the diversity of its applications in various sectors, especially in the field of human health monitoring, this new issue is receiving increasing attention. A top priority for WBANs is finding ways to reduce the power consumption of sensors, which are typically powered by cells or batteries with limited storage space.

First, we made a broad introduction to our thesis in which the problem and goal were defined. In Chapter 1, we gave an overview of WBANs, including body sensor network architecture and operation, working topologies and applications of WBANs, as well as WBAN issues. We have categorized the routing protocols and identified the most important thing each protocol does in Chapter 2.

In Chapter 3, we briefly analyzed the current routing protocol used in WBANs, particularly in the Internet of Things (RPL). Clearly, a routing protocol is essential to the development of any effective, reliable, and affordable wireless sensor network. Routing protocols for WBANs are divided into five classes based on the shape and type of networks: block-based, layer-based, traffic-based, QoS-sensitive, and temperature-sensitive. It was found that each protocol must meet four conditions to be classified as the best protocol, namely that it must consume the minimum amount of energy, the information transmission process must be fast because the measurement or the delay in transmission leads to the death of the person, that the temperature is not high So much so that the nodes may overheat due to transmitting and receiving, so that the standards do not conflict and are complementary to each other.

Distinctive protocols are used for regular tracking and critical medical cases. A parameter comparison study was performed for each protocol in order to select the best one for the target application. In order to focus on the challenges of open research, the two challenges should focus on the different parameters that need to be addressed while designing routing protocols in WBAN. It is also useful while examining the WBAN routing protocols currently used in healthcare systems. They are power consumption, traffic control, and packet delivery ratio And ETX and the number of hops.

Among the tasks to be completed in the future is the creation and application of a body sensor prototype using an innovative, energy-efficient and reliable routing protocol for rehabilitation of the elderly using a microcontroller-based system with appropriate sensors. Future routing protocols for WBANs must be taken into account for reliable QoS and data. So, data security must be taken into consideration.

To transfer data successfully, networks must be upgraded in terms of capacity and quality. More biosensors can be applied to the human body to prevent hotspot nodes, by designing a steering system that consumes as little energy as possible, this can be achieved. As a result, the tissues of the human body will not be affected.

Reference

- 1-** Reema Goyal, 1 Nitin Mittal and others, Chandigarh University, Mohali, India. Routing Protocols in Wireless Body Area Networks: Architecture, Challenges, and Classification. Hindawi Wireless Communications and Mobile Computing Volume 2023, Article ID 9229297, 19 pages. published 17 january 2023,wrote in 1 april 2023.
- 2-** Bangash, J.I. ; Abdullah, A.H. ; Anisi, M.H. ; Khan, A.W. A Survey of routing protocols in Wireless body sensor networks. Sensors 2014, 14, 1322–1357,wrote in 1 april 2023 .
- 3-** K. Hasan, K. Biswas, K. Ahmed, N. S. Nafi, and M. S. Islam, "A comprehensive review of wireless body area network," Journal of Network and Computer Applications, vol. 143, pp. 178-198, 2019. doi:http://dx.doi.org/10.1016/j.jnca.2019.06.016.,wrote in 06jun 2023.
- 4-** B. Latré, B. Braem, I. Moerman, C. Blondia, and P. Demeester, "A survey on wireless body area networks," Wireless networks, vol. 17, no. 1, pp. 1-18, 2011. doi: http://dx.doi.org/10.1007/s11276-010-0252-4,wrote in 06jun 2023.
- 5-** Zhong, L. ; He, S. ; Lin, J. ; Wu, J. ; Li, X. ; Pang, Y. ; Li, Z. Technological Requirements and Challenges in Wireless Body Area Networks for Health Monitoring : A Comprehensive Survey. Sensors 2022, 22, 3539 ,wrote in 3 april 2023.
- 6-** Al-Sauda, K.A. ; Mohamed, A. ; Mahmuddin, M. Survey on Wireless Body Area Sensor Networks for healthcare applications : Signal Processing, data analysis and feedback. In Proceedings of the 3rd International Conference on Computing and Informatics (ICOCI 2011), Bandung, Indonesia, 8–9 June 2011,wrote in 5 april 2023.
- 7-** Saleh, Y.N. ; Chibelushi, C.C. ; Abdel-Hamid, A.A. ; Soliman, A.H. Privacy Preservation for Wireless Sensor Networks in Healthcare : State of the Art, and Open Research Challenges. ArXiv 2020, arXiv :2012.12958,wrote in 8 april 2023.
- 8-** Rahangdale, H. A Review on WMSN (Wireless Medical Sensor Networks) for Health Monitoring Systems. ECS Trans. 2022, 107, 1973,wrote 12 in april 2023.
- 9-** Huynh, D.T. ; Chen, M. An energy efficiency solution for WBAN in healthcare monitoring system. In Proceedings of the 2016 3rd International Conference on Systems and Informatics (ICSAI), Shanghai, China, 19–21 November 2016 ; IEEE : Piscataway, NJ, USA, 2016 ; pp. 685–690,wrote in 13 april 2023 .
- 10-** Mounsla, H. ; Touati, N. ; Mehaoua, A. Efficient heterogeneous communication range management for dynamic WBAN topology routing. In

Reference

Proceedings of the 2013 First International Symposium on Future Information and Communication Technologies for Ubiquitous Ubiquitous (Ubi-HealthTech), Jinhua, China, 1–3 July 2013 ; IEEE : Piscataway, NJ, USA, 2013 ; pp. 1–5,wrote in 15 april 2023.

11- Cornet, B. ; Fang, H. ; Ngo, H. ; Boyer, E.W. ; Wang, H. An Overview of Wireless Body Area Networks for Mobile Health Applications. IEEE Net. 2022, 36, 76–82,wrote in 15 april 2023.

12- Ullah, S. ; Shen, B. ; Islam, S.R. ; Khan, P. ; Saleem, S. ; Kwak, K.S. A study of MAC protocols for WBANs. Sensors 2009, 10, 128–145,wrote 15 april 2023.

13- Kurian, A. ; Divya, R. A Survey on energy efficient routing protocols in wireless body area networks (WBAN). In Proceedings of the 2017 International Conference on Innovations in Information, Embedded and Communication Systems (ICIIECS), Coimbatore, India, 17–18 March 2017 ; IEEE : Piscataway, NJ, USA, 2007 ; pp. 1–6,wrote in 16 april 2023.

14- Sagar, A.K. ; Banda, L. ; Sahana, S. ; Singh, K. ; Singh, B.K. Optimizing quality of service for sensor enabled Internet of healthcare systems. Neurchi. Inform. 2021, 1, 100010,wrote in 18 april 2023.

15- Filipe, L. ; Fdez-Riverola, F. ; Costa, N. ; Pereira, A. Wireless body area networks for healthcare applications : Protocol stack review. Int. J. Distrib. Sens. Netw. 2015, 11, 213705 ,wrote in 18 april 2023.

16- Asam, M. ; Jamal, T. ; Adeel, M. ; Hassan, A. ; Butt, S.A. ; Ajaz, A. ; Gulzar, M. Challenges in wireless body area network. Int. J. Adv. Comput. Sci. Appl. 2019, 10, 336–341,wrote 18 april 2023.

17- Channa, A. ; Popescu, N. ; Skibinska, J. ; Burget, R. The rise of wearable devices during the COVID-19 pandemic : A systematic review. Sensors 2021, 21, 5787,wrote in 27april 2023.

18- Darwish, A. ; Hassanien, A.E. Wearable and implantable wireless sensor network solutions for healthcare monitoring. Sensors 2011, 11, 5561–5595 ,wrote in 27 april 2023.

19- Barakah, D.M. ; Ammad-uddin, M. A Survey of challenges and applications of wireless body area network (WBAN) and role of a virtual doctor server in existing architecture. In Proceedings of the 2012 3th International Conference on Intelligent Systems Modelling and Simulation, Kota Kinabalu, Malaysia, 8–10 February 2012; IEEE : Piscataway, NJ, USA, 2012 ; pp. 214–219,wrote in 29 april 2023.

Reference

- 20-** Bouhassoune, I. ; Saadane, R. ; Chehri, A. Wireless body area network based on RFID system for healthcare monitoring : Progress and architectures. In Proceedings of the 2019 15th International Conference on Signale-Image Technology Internet-Based Systems (SITIS), Sorrento-Naples, Italy, 26–29 November 2019 ; IEEE : Piscataway, NJ, USA, 2019 ; pp. 416–421,wrote in 29 april 2023.
- 21-** Javed Iqbal Bangash. ; Abdul Hanan Abdullah and others. A Survey of Routing Protocols in Wireless Body Sensor Networks, www.mdpi.com/journal/sensors, Published 13 January 2014,wrote in 2 march 2023.
- 22-** Kornepati Sai Sandeep and others. TARA : Thermal-Aware Routing Algorithm for Implanted Sensor Networks, Published June 2005,wrote in 2 march 2023.
- 23-** Faisal Jamil and others. Adaptive Thermal-Aware Routing Protocol for Wireless Body Area Network. Published 1 January 2019,wrote in 3 march 2023.
- 24-** Australia Samaneh Movassaghi. ; Mehran Abolhasan. A Review of Routing Protocols in Wireless Body Area Networks. Published MARCH 2013,wrote in 4 march 2023.
- 25-** Bag, A. ; Bassiouni, M.A. Energy Efficient Thermal Aware Routing Algorithms for Embedded Biomedical Sensor Networks, Published 12 October 2006,wrote in 4 march 2023.
- 26-** Anirban Bag and others, Hotspot Preventing Routing algorithm for delay-sensitive applications of in vivo biomedical sensor networks. Published 21 February 2007,wrote in 4 march 2023.
- 27-** Shabnam Jalili Marandi, Mehdi Golsorkhtabaramiri and others. IoT based thermal aware routing protocols in wireless body area networks : Survey : IoT based thermal aware routing in WBAN . Published 29 May 2022,wrote in 8 march 2023.
- 28-** Liang, X., & Balasingham, I. (2007, October). A QoS-aware routing service framework for biomedical sensor networks. In 2007 4th International Symposium on Wireless Communication Systems (pp. 342-345). IEEE,wrote in 10 march 2023.
- 29-** Tabandeh, M. Jahed, M. and others. A Thermal-Aware Shortest Hop Routing Algorithm for in vivo Biomedical Sensor Networks. Published 29 April 2009,wrote in 15 march 2023.
- 30-** Javaid, N. ; Abbas, Z. and others. M-ATTEMPT : A new energy-efficient routing protocol for wireless body area sensor networks, Published 2013,wrote in 15 march 2023.

Reference

- 31-** Liang, X., & Balasingham, I. (2007, October). A QoS-aware routing service framework for biomedical sensor networks. In 2007 4th International Symposium on Wireless Communication Systems (pp. 342-345). IEEE,wrote in 20 march 2023.
- 32-** Djenouri, D., & Balasingham, I. (2009, September). New QoS and geographical routing in wireless biomedical sensor networks. In 2009 Sixth International Conference on Broadband Communications, Networks, and Systems (pp. 1-8). IEEE,wrote in 20 march 2023.
- 33-** Anand Kumar M, Dr. C. Vidya Raj. A Comprehensive Survey of QoS-Aware Routing Protocols in Wireless Body Area Networks, Published 1 January 2017,wrote in 20 march 2023.
- 34-** Djenouri, D., & Balasingham, I. (2009, September). New QoS and geographical routing in wireless biomedical sensor networks. In 2009 Sixth International Conference on Broadband Communications, Networks, and Systems (pp. 1-8). IEEE, wrote in 22 march 2023.
- 35-** Melody Moh, Design and analysis of Hybrid Indirect Transmissions (HIT) for data gathering in wireless micro sensor networks, ACM SIGMOBILE Computing and communications Review, Published January 2004,wrote in 20 march 2023.
- 36-** Thomas Watteyne, Mischa Dohler, AnyBody : a Self-organization Protocol for Body Area Networks,wrote in 25 march 2023.
- 37-** V. Bhanumathi and C. P. Sangeetha, A guide for the selection of routing protocols in WBAN for healthcare applications, Published (2017),wrote in 25 march 2023.
- 38-** Farman Ulla, M. Zahid Khan. Energy Efficiency and Reliability Considerations in Wireless Body Area Networks : A Survey, Published 17 January 2022,wrote in 27 march 2023.
- 39-** Omar Smail, Adda Kerrar and others. ESR : Energy aware and Stable Routing protocol for WBAN networks. Published 26 May 2016,wrote in 27 march 2023.
- 40-** Movassaghi, S. ; Abolhasan, M. Energy Efficient Thermal and Power Aware (ETPA) Routing in Body Area Networks, Published 12 September 2012,wrote in 28 march 2023.
- 41-** Techjury.net,wrote in 2 mai 2023.

Reference

42- ContikiOS1, (2018) <http://www.contiki-os.org/> (accessed on 8.21.2018), wrote in 2 mai 2023.

43- Contiki OS2, (2018)

http://anrg.usc.edu/contiki/index.php/Main_Page(accessed on 9.21.2018), wrote in 15 mai 2023.

44- Kharrufa, H, Al-Kashoash, HAA and Kemp, AH (2019) RPL-Based Routing Protocols in IoT Applications : A Review. IEEE Sensors Journal, 19 (15). pp. 5952-5967. ISSN 1530-437X , <https://doi.org/10.1109/JSEN.2019.2910881> , wrote in 18 mai 2023.

