

REPUBLIQUE ALGERIENNE DEMOCRATIQUE ET POPULAIRE  
MINISTRE DE L'ENSEIGNEMENT SUPERIEUR ET DE LA RECHERCHE SCIENTIFIQUE  
UNIVERSITE MOHAMED BOUDIAF - M'SILA

Faculté des Mathématiques et de  
l'Informatique

Département d'Informatique

N° : .....



DOMAINE : Mathématiques et  
Informatique

FILIERE : Informatique

OPTION : .....

Mémoire présenté pour l'obtention  
Du diplôme de Master Académique

Par: Mekki Dounya  
Sahraoui Bouchra

Intitulé

**RRH-BBU  
assignment in Cloud Radio Access Networks**

Soutenu devant le jury composé de :

Nom et prénom Enseignant

Université de M'sila

Président

**Sayad Lamri**

Université de M'sila

Rapporteur

.....

Université de M'sila

Examineur

Année universitaire : 2021 / 2022



REPUBLIQUE ALGERIENNE DEMOCRATIQUE ET POPULAIRE  
MINISTERE DE L'ENSEIGNEMENT SUPERIEUR ET DE LA RECHERCHE SCIENTIFIQUE  
UNIVERSITE MOHAMED BOUDIAF - M'SILA

Faculté des Mathématiques et de  
l'Informatique

Département d'Informatique

N° : .....



DOMAINE : Mathématiques et  
Informatique

FILIERE : Informatique

OPTION : .....

Mémoire présenté pour l'obtention  
Du diplôme de Master Académique

Par: Mekki Dounya  
Sahraoui Bouchra

Intitulé

**RRH-BBU  
assignment in Cloud Radio Access Networks**

Soutenu devant le jury composé de :

Nom et prénom Enseignant

Université de M'sila

Président

**Sayad Lamri**

Université de M'sila

Rapporteur

.....

Université de M'sila

Examineur

Année universitaire : 2021 / 2022

## Dedication

- ❖ Praise be to God, who opened the doors of success for me, set my path for me, and made up for what I missed. Thank you for the pitfalls I encountered in my path, because it taught me that whoever does not suffer does not learn, and that falling is the beginning of success. May God bless you for a lifetime...No matter what I said or did, I never thanked you properly. Thanks to your encouragement, kindness and presence by my side, I have made this respectable journey.
- ❖ I hope you are proud of me and that I was able to fulfill the hopes you placed in me  
Thank you dad... mom...
- ❖ My brothers...the first line of defense...and the safe haven...the permanent bond...to all those for whom I have all the love and respect, to those who always wish the best for me..
- ❖ .To my fiancé, to all the family of Mekki, Ben Djoudi , Yahia El Sharife and
- ❖ Djawada., to all those for whom I have all my love and respect, to those who always wish me well...
- ❖ To my friends the beautiful thing in everything Positive energy Feeling safe Thank you To those who taught me a letter one day, to everyone who was credited with my arrival here, to everyone in the heart, whose names did not fit the lines....., and finally to everyone who contributed directly or indirectly to the completion This work even if praying.

Thanks.

## Dedication

- ❖ Praise be to God, who opened the doors of success for me... and charted my way for me and compensated me for what I missed...
- ❖ Thank you for the bumps I encountered on my way...because it taught me that he who does not suffer does not learn and that falling is the beginning of success...
- ❖ I present my success to my mother and father... and I say what I have become now is from God's grace to me.... Hence your satisfaction, may God bless you for a whole life.... Thank you, my father... Thank you, my mother....
- ❖ Thank you.....to my brothers...the first line of defense...and the safe haven...the permanent bond...
- ❖ Thank you... to all those for whom I have all the love and respect, to those who always wish me well (y.ked)...
- ❖ Thank you... to my friends, the beautiful thing about everything, the positive energy, the feeling of safety, especially (Wiam, Ikram)....
- ❖ Thank you.... to those who taught me a letter one day, to everyone who was credited with getting me here, to everyone in the heart, and their names could not contain the lines.... Especially (Dr. Wafaa).....
- ❖ Thank you....to my family, the supportive family....(Sahraoui) ... family...the ones close to them and far away...

## **Thanks**

First, I would like to thank God for giving me the strength, will and patience to complete This humble work. Next, I would like to thank my supervisor, Dr. Sayad Lamri for his work Managing this business, my best wishes for complete health, longevity and always Tenderness and tenderness, and I also do not forget to thank everyone Professors of the Faculty of Mathematics and Computer Science at the University of M'Sila In general, and computer science professors in particular. I would like to thank all the people Who helped me directly or indirectly in completing this work.

# Table of content

Dedication.....	I
Thanks.....	IV
Table of content.....	V
List of tables.....	VII
List of figures .....	VIII
List abbreviations.....	IX
General Introduction.....	1
<b>Chapter 1: Background</b> .....	<b>3</b>
1. Introduction.....	4
1.1 Radio Access Network.....	4
1.1.1 Components RAN.....	5
1.1.2 Types of Radio Access Network (RAN). .....	5
1.2 C-RAN architecture.....	6
1.3 C-RAN benefits.....	8
1.4 Drawbacks of C-RAN.....	10
1.5 C-RAN challenges.....	10
1.6 C-RAN and 5G.....	12
2. Conclusion.....	13
<b>Chapter 2 C-RAN optimization: Mathematical background and state-of-the-art</b> .....	<b>14</b>
1. Introduction.....	15
1.1. Related work.....	15
2. System model.....	20
2.1 Network model.....	20
2.2 Energy model.....	22
3. Problem formulation.....	21
3.1 RRH-BBU association constraints.....	21
3.2 Process capacity constraints.....	21
3.3 Power supply constraints.....	21
4. Conclusion.....	25

<b>Chapter 3 Design And Implementation</b> .....	26
1.Introduction.....	27
1.1Netbeans.....	27
1.2 Reminders for Java Architecture.....	28
1.3 General description of the architecture.....	28
2. Implementation.....	30
2.1 the BBU class.....	30
2.2 The RRH class.....	31
2.3 The BBURRH class.....	32
2.4 The main class.....	33
2.5 Results.....	34
Conclusion.....	36
Bibliography.....	37
Abstract.....	40

## **List of tables**

Table 1: Related work.....	16
Table 2 : List of notations.....	21

## List of Figures

Figure1.1: Basic RAN architecture.....	5
Figure1.2: Traditional RAN to C-RAN architecture.....	7
Figure1.3: C-RAN architecture and components.....	8
Figure1.4: Small cell-based C-RAN architecture for 5G networks.....	13
Figure2.1: Green energy powered C-RAN.....	20
Figure 3.1: NetBeans IDE 8.2.....	27
Figure 3.2: The execution environment of a Java programme.....	28
Figure 3.3 the BBU class.....	30
Figure 3.4: The RRH class .....	31
Figure 3.5: The BBURRH class.....	32
Figure 3.6: the main class.....	33
Figure 3.7: the result.....	34
Figure 3.8: the result2.....	35

## List of abbreviations

- BBU: BaseBand Unit.
- CAPEX: CAPital Expenses.
- COMP: Coordinated Multi-Point
- CoMPT: coordinated multi-point transmission.
- CPU: Central Processing Unit.
- C-RAN: Cloud-Radio Access Network.
- CPRI: Common Protocol Radio Interface.
- DAS :Distributed Antenna Systems .
- DSP: Digital Signal Processing.
- D-RAN: Distributed RAND.
- EE.energy efficiency .
- E-UTRAN: Evolved Universal Terrestrial RAN,
- eMBB: enhanced Mobile BroadBand.
- eICIC: enhanced inter-cell interference coordination .
- eNodeB: evolved Node B.
- EPC: Evolved Packet Core • FFD: First-Fit Decreasing.
- GSM: Global System for Mobile communications.
- GSM EDGE RAN: Enhanced Data GSM Environment.
- HARQ: Hybrid Automatic Repeat request.
- ICIC: Inter-cell Interference Coordination.
- ILP: Integer Linear Programming.
- IoT: Internet of Thing.
- LP: Linear Programming.
- MAC: Medium Access Control.
- MINLP; mixed integer Nonlinear programming .
- MILP: Mixed Integer Linear Program.
- mMTC: massive Machine-Type Communications.
- mmWave: millimeter Wave.
- NFV:network function virtualization .
- OAI: OpenAirInterface.
- OPEX: OPerating Expenses.
- PHY: Physical layer.

- QoS: Quality of Service .
- RAN: Radio Access Network
- RF: Radio Frequency.
- RLC: Radio Layer Control.
- RRH: Remote Radio Heads.
- SA: Simulated Annealing.
- SE: spectral efficiency.
- SDC-RAN:a software-defined cloud radio access network .
- SDN: Software Defined Network.
- SDR: Software Defined Radio.
- UE: User Equipment.
- URLLC: Ultra-Reliable and Low-Latency Communications .
- UMTS: Universal Mobile Telecommunications System.
- VM: Virtual Machine.
- 3GPP: Third Generation Partnership Project.
- 4G: Fourth Generation.
- 4G-LTE: Fourth Generation-Long Term Evolution.
- 5G: Fifth Generation.

## **General Introduction**

# General Introduction

## General Introduction

The emergence of mobile cloud computing in wireless networks makes it possible to develop new services in a more flexible environment, which RAN must also take into account. Mobile devices are ubiquitous, from Smartphone to connected objects (vehicles, machines, cities, etc.). As a result, data traffic has grown exponentially in recent years and appears to be accelerating. To keep pace with this growth, mobile operators must redouble their efforts to increase the capacity of their access networks. Network refinement has been suggested as a solution to this problem. However, this solution is very expensive as it requires the implementation of new access points. In this case, in order to reduce costs, the Cloud RAN network is proposed, which provides all the advantages of a typical cloud computing.

Cloud RAN is a very promising network for the next generation of 5G cellular networks as it has the opportunity to take advantage of all the contributions of cloud computing, particularly in terms of flexibility, scalability, efficiency and performance. As a result, changes can be more easily incorporated into emerging wireless network technologies. As a result, C-RAN enables baseband functionality to be virtualized in the cloud for centralized management and processing. Therefore, C-RAN combines better spectral efficiency and power with lower costs. However, it also raised challenges that still need to be addressed, such as limited capacity of front-end networks, resource allocation, cell aggregation, security, etc. Within this framework, our research work is being carried out with the aim of suggesting a new approach to improve the performance of C-RAN networks.

Cloud RAN has been proposed to deal with the traffic explosion. Which separates the baseband processing unit (BBU) from the remote radio header (RRH). On the other hand, it is widely believed that heavy use leads to a significant increase in energy consumption. Therefore, reducing electricity consumption in the network becomes an interesting topic. Smart grids break the boundaries of traditional grids, focusing on distributed power generation (DER) and bidirectional power distribution, resulting in a wireless power source. In this work, we investigate combined RRH-BBU to reduce the association of Brownian energy consumption and energy allocation problems in C-RAN to green energy.

# General Introduction

The problem was formulated in the form of Mixed Integer Linear Programming (MILP) to deal with the computational complexity of a MILP solution, and the experimental two-stage polynomial algorithm was proposed and evaluated via extensive simulation-based studies. However, this new paradigm also brings with it its own challenges. For example, remote users, cloud resources, front-end network bottlenecks, C-RAN capacity bottlenecks, etc. need to update the architecture. Moreover, the release of a large number of RRHs leads to significant perturbations. Especially in the uplink, each RRH compresses the received signal so that it can be sent to the central BBU via the bound forward link. In addition, the processing of large amounts of data by mobile devices limits their battery life on the one hand, and on the other hand, a large number of BBUs must be activated to meet user requirements. Therefore, C-RAN systems must also deal with the associated power consumption issues at the network and mobile station level. These issues are addressed in our work by examining common RRH-BBU issues of correlation and energy sharing to reduce brown energy consumption in green-powered C-RAN.

## **Structure of the note :**

This report is organized as follows:

- The first chapter presents the basic concepts necessary to understand the problem. First, it presents the concept of wireless access network and its components RAN and types of wireless access network (RAN), and we touched on the structure of C-RAN, the benefits of C-RAN and some of its disadvantages C-RAN and the challenges of C-RAN and finally the relationship between C-RAN and 5G.
- The second chapter describes some of the previous work and studies related to our research, and we also touched on introducing an in-depth analysis system model, including the network model and the energy model.
- The third chapter describes the programming environment and introduces the realized application.

Finally, we concluded our work with a general conclusion.

# **Chapter 1**

## **background**

# Chapter 1

## Background

### 1. Introduction

The exponential growth of mobile traffic is a real obstacle for mobile network operators today. New traffic patterns with different latency and bandwidth requirements are introduced. Faced with such demands, mobile network operators employ flexible and efficient solutions to meet ongoing traffic demands without compromising their financial cost and return on investment. Cloud Radio Access Networks, known as Cloud-RAN or C-RAN, were introduced to address the challenges faced by MNOs and their requirement to reduce capital expenditure (CAPEX) and operational expenditure (OPEX). The concept of C-RAN architecture is based on "cloudification". In particular, the baseband processing elements, or BBUs, will be migrated to cloud data centers, where centralized management of baseband tasks will be introduced. Lightweight Radio Components (i.e. RRHs), Still distributed in many locations to provide access to the UE. This chapter introduces the C-RAN architecture and compares it with the traditional architecture Distributed RAN (D-RAN). In addition, the rationale behind the C-RAN architecture is presented and various challenges are outlined. This chapter also describes the purpose of the work .

### 1.1 Radio Access Network

A radio access network (RAN) is the part of a mobile network that connects end-user devices, like smart phones, to the cloud. This is achieved by sending information via radio waves from end-user devices to a RAN's transceivers, and finally from the transceivers to the core network which connects to the global internet. For telecommunications network operators, RANs are crucial connection points that represent significant overall network expenses, perform intensive and complex processing, and now face rapidly increasing demand as more edge and 5G use cases emerge for Telco customers. Just as the virtualization of network functions has enabled telcos to modernize their networks, similar principles can also be applied to RAN. This is especially important as the future of the industry focuses on the transition to 5G—in fact, the ongoing 5G network transformation often depends on the virtualization of RAN, and increasingly assumes that it is container-based and cloud-native[1].

### 1.1.1 Components RAN:

RAN components include base stations and antennas that cover a specific region, depending on their capacity. Silicon chips in both the core network and the user equipment provide RAN functionality[2].

A RAN is made up of three essential elements:

1. Antennas convert electrical signals into radio waves.
2. Radios transform digital information into signals that can be sent wirelessly and ensure that transmissions are in the correct frequency bands with the right power levels.
3. Baseband units (BBUs) provide a set of signal processing functions that make wireless communication possible. Traditional baseband uses custom electronics combined with multiple lines of code to enable wireless communication, typically using the licensed radio spectrum. BBU processing detects errors, secures the wireless signal and ensures that wireless resources are used effectively.

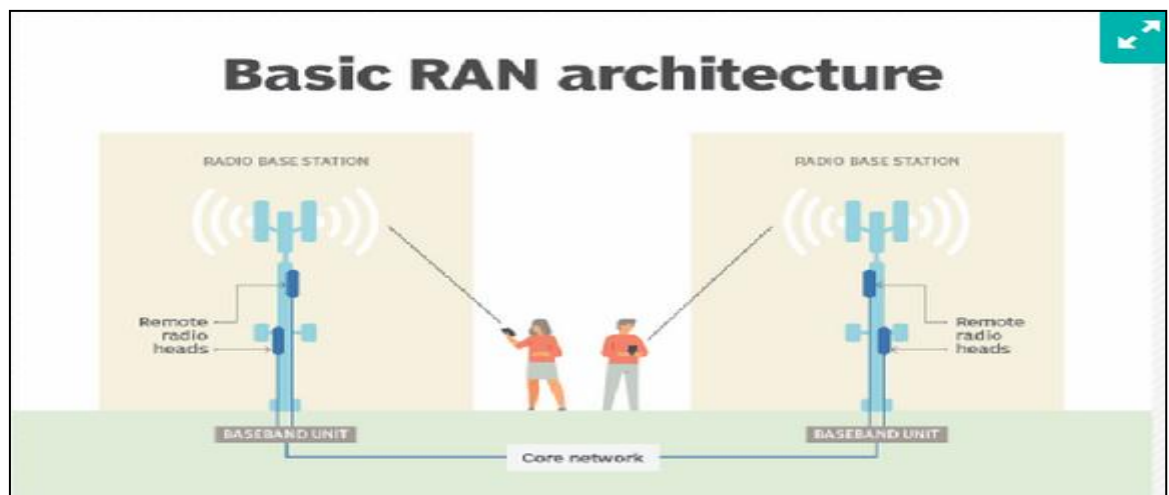

Figure1.1: Basic RAN architecture.

### 1.1.2 Types of Radio Access Network (RAN)

RAN trends include the following[2]:

- **Open RAN** is the hot topic in the access network world. It involves developing interoperable open hardware, software and interfaces for cellular wireless networks that use white box servers and other standard equipment, rather than the custom-made hardware typically used in base stations.
- **D-RAN Architecture** In conventional architecture, base stations operate in a distributed fashion. In particular, each base station deployed on a site, consists of a BBU and a RRH. The BBU is an intelligent element used to perform the baseband tasks functionalities (i.e, physical and MAC layers functionalities). The RRH is a light weighted radio element, acting as a passive antenna, and used to perform signal modulation and amplification. The BBU and RRH are linked through a fiber optic link using the Common Protocol Radio Interface (CPRI) .

- **C-RAN** separates the radio elements in a base station into remote radio heads (RRHs). These can be used atop the cell towers for the most efficient radio coverage. RRHs must be connected to centralized baseband controllers via fiber or microwave radio links. Most base band processing uses standard white box servers.
- **Global System for Mobile communications (GSM) RAN**, or GRAN, was developed for 2G.
- **GSM EDGE RAN**, or GERAN is similar to GRAN, but it specifies the inclusion of Enhanced Data GSM Environment packet radio services.
- **Universal Mobile Telecommunications System (UMTS) Terrestrial RAN**, or UTRAN, came about with 3G.
- **Evolved Universal Terrestrial RAN**, or E-UTRAN, is part of LTE.

In the following, we detail the fundamental aspects of C-RAN architecture and its main components. Then, we discuss the main advantages of this architecture and finally, we outline the most important challenges that we are facing while deploying C-RAN architecture.

## 1.2 C-RAN architecture

Current generation mobile networks use traditional radio access networks (RAN), including where the radio and baseband processing functions are located the same base station. Indeed, as shown in Figure 1.2, traditional base stations Consists of two components, the antenna (RRH) and the BBU (data center), located in the same macro site (eNodeB). However, these networks no longer exist Capable of delivering high data rates to meet and guarantee high latency requirements High QoS for end-user needs. To achieve these goals, C-RAN Proposed as a promising architecture for next-generation cellular networks (5G) Meet diverse service needs. The main concepts of C-RAN are Decouple the BBU from the antenna and bundle computing resources In the central data center, i. H. BBU pool. The BBU compute pool will Shared by multiple base stations to achieve resource utilization gain and save network costs..Figure 1.2 illustrates the main difference between the traditional RAN (the left part of Figure 1.2) and C-RAN architecture (the right part of Figure 1.2) in terms of resource pooling and BBU centralization.

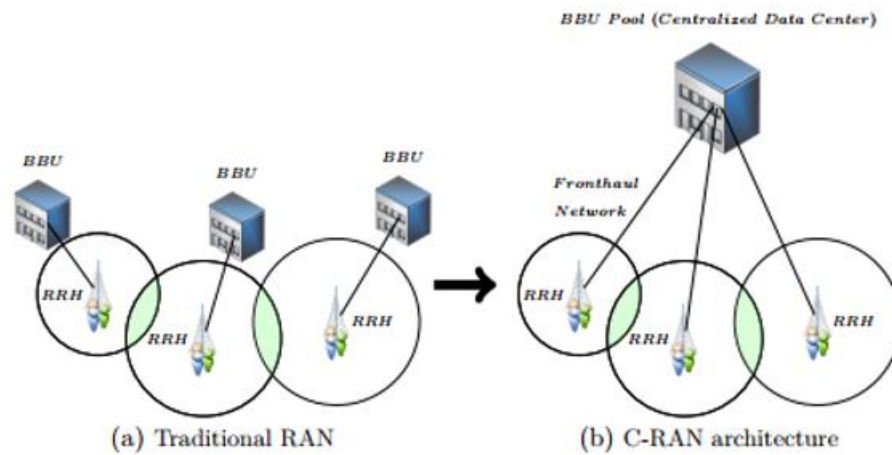

Figure1.2: Traditional RAN to C-RAN architecture.

As mentioned above, the proposed C-RAN architecture consists in centralizing the baseband processing of antennas demands from several cell sites in BBU pools when the RRHs are connected to the centralized data centers through fronthaul network. Figure 1.3 illustrates C-RAN architecture focusing on three main components:

- **RRHs or antennas:** are located at the cell sites and they forward the baseband signals received from User Equipments (UEs) to the BBU pools for centralized processing in the uplink while transmitting Radio Frequency (RF) signals to UEs in the downlink. RRHs perform radio functions including RF conversion, amplification, filtering, analog-to-digital conversion and digital-to-analog conversion.

- **BBU pool or centralized data center:** is a centralized location of computing and processing resources shared among multiple cell sites. In fact, each BBU pool can serve 10 to 1000 RRHs and it consists in centralizing the processing of baseband signals of antennas demands and then optimizing the allocation of computing resources.

- **Fronthaul network:** is a set of communication links between RRHs and BBU pool. The fronthaul traffic exchanged between antennas and centralized data centers can be transmitted using typical protocols including OBSAI and CPRI, which is the most widely used in cellular networks. Fronthaul network can be released by different technologies such as optical fiber communications, standard wireless communications, or millimeter Wave (mmWave) communications [3].

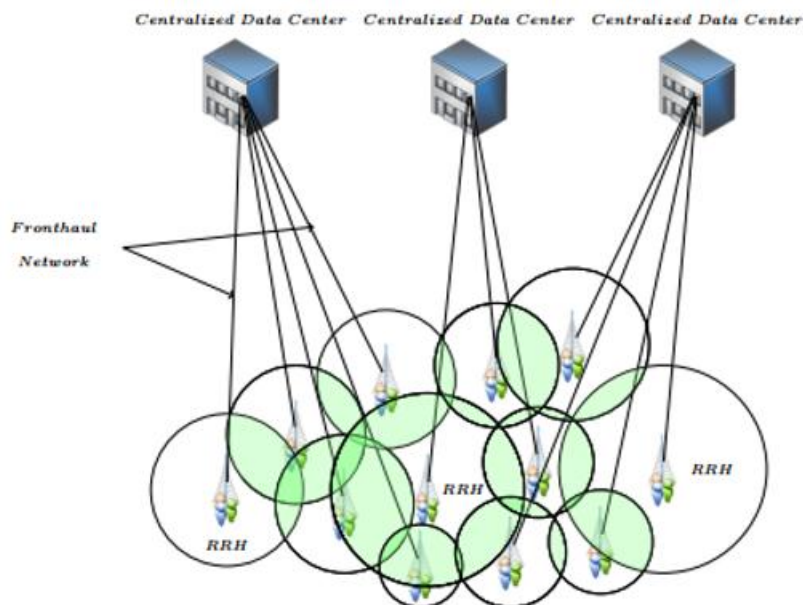

Figure1.3: C-RAN architecture and components

### 1.3 C-RAN benefits

C-RAN has some great advantages over the existing counterpart as summarized below [4].

- Reduced CAPEX (CAPitalEXPenses) and OPEX (OPERatingEXPenses):** Deployment and commissioning of a macrocell BS (MBS) is expensive and time-consuming. In contrast, C-RAN involves less cost, space and time to deploy, install, and operate RRHs. Furthermore, C-RAN can make it possible to more effectively equipment sharing leading to reduced CAPEX. A quantitative analysis presented in [4] showed that CRANs has the potential to reduce CAPEX up to 15% per kilometer. Besides, computing resources in C-RAN are aggregated in few big clouds leaving simpler functions in RRHs, which can save a large portion of OPEX and management cost.
- Improved EE:** Number of BBUs required in a C-RAN is less than a conventional RAN leading to reduction in power consumption. Besides, air conditioning of radio modules in C-RANs can be decreased around 90% as RRHs are naturally cooled by air hanging on masts or building walls. Furthermore, C-RANs allow both UEs and MBSs to offload their data intensive energy-consuming computations to a nearby cloud saving their energy. One study conducted by ZTE estimated that C-RAN can achieve up to 80% energy savings compared to traditional RAN.
- Improved spectral efficiency (SE):** C-RAN can also improve the SE of cellular networks. For instance, implementation of coordinated and cooperative transmission/reception strategies, such as enhanced inter-cell interference coordination (eICIC) and coordinated multi-point transmission (CoMP) across the RRHs connected to the same cloud will be much simpler and more effective resulting in higher SE.

- **Reduced latency:** C-RAN has the capability to reduce latency in performing various operations. For instance, the time needed to perform handovers will be reduced as it can be done inside a cloud instead of between BSs. Failure rate in handover can also be decreased. Moreover, the general amount of signaling information sent to core network can be reduced in C-RAN and hence latency will be reduced.
- **Facilitate the switching of BBUs:** C-RAN relaxes the constraint of keeping each BS on for all time. As all processing functionalities are implemented in a remote cloud, power and load congestion can be reduced by dynamically allocating processing capability and migrating tasks in the BBU pool. Thus several BBUs can be turned to low power sleep mode or even be shut down for saving energy.
- **Improved interference management:** C-RAN enables ease sharing of channel state information (CSI), traffic data and control information of mobile services among cooperating BSs. This will allow more effective multipoint cooperation and enable multiplexing more streams on the same channel with substantially reduced mutual interference. Due to the decrease of interference, link quality as well as throughput will be greatly improved.
- **Ease of maintenance and expansion:** The inherent centralized architecture of C-RAN makes it easily scalable and thus simplifies the cellular network upgrading and maintenance. For example, a network operator only needs to add new RRHs connecting with the cloud for covering more service areas or split the cell for higher capacity. C-RAN also facilitates on demand installation of virtual resources in cloud. Besides, C-RAN provides a smooth way for introducing new standards, as hardware needs to be placed in few centralized locations. Moreover, centralization of BBUs in cloud enables easy and more frequent CPU updates than that in the traditional systems. Furthermore, the native centralized support for multi-standard operation will make inter-RAN operation relatively easy.
- **Adaptability to non-uniform traffic:** Modern day cellular networks exhibit a substantial amount of tempo-spatial diversity in traffic. However, BSs are dimensioned for busy hours implying a wastage of processing power during off-peak hours. Since in C-RAN, baseband processing of multiple BSs is carried out in the centralized BBU pool, resources to the BSs can be allocated in an optimum way based on the instantaneous traffic demand and thus the overall resource utilization rate can be improved.

## 1.4 Drawbacks of C-RAN

C-RAN also has some shortcomings that need to be addressed before implementing a C-RAN based cellular network. For example, the security and trust issues of C-RAN are one of the main issues of particular concern. In a wireless network, due to its open transmission nature, it can be accessed by authorized or unauthorized users. In addition to security threats common to traditional wireless networks, such as Due to its own provision, C-RAN will face more serious security threats and trust issues . Also, C-RAN faces a huge risk of a single point of failure as many BS's BBUs are clustered in the cloud, ie. H. If the cloud goes down, the entire network goes down. On the other hand, the RAN architecture introduces huge overhead for the optical fronthaul link between the RRH and the cloud., which can be up to 50 times higher than the backhaul requirement . Furthermore, latency/jitter between cloud and RRH, complex operating system operations in cloud, and the risk of losing native hardware compatibility are some of the major drawbacks of C-RAN . In some cases, there is also an opportunity to increase latency due to centralized signal processing[4].

## 1.5 C-RAN challenges

While the C-RAN architecture brings all the advantages (as described above), the Many challenges must be addressed to enable and facilitate deployment via C-RAN. In this section, we will focus on the main challenges of C-RAN mentioned in this manuscript[3].

- **Strong latency expectations on front haul network:** in C-RAN architecture, the fronthaul network that connects RRHs to BBU pools must carry a significant amount of data traffic demands in real time with high bandwidth and strong latency requirements. In fact, the transmission delay on a link between RRHs and the centralized data centers should be kept below **1 millisecond** to meet HARQ<sup>1</sup>requirements which impose that the maximum distance between RRH and BBU pool must not exceed 20 to 40 kilometers[21].
- The fronthaul capacity and delay constraints can be alleviated by flexibly splitting the baseband processing between BBU pools and RRHs. The envisioned solution consists in moving a part of baseband processing functions in centralized data centers in order to reduce the increasing data throughput and the overheads of the signal transmitted through fronthaul network. The evaluation of different options of BBU functions split in C-RAN will be detailed of Chapter 2.

---

<sup>1</sup>HARQ (Hybrid Automatic Repeat reQuest) is the process that poses the most stringent delay requirement for cellular networks.

- **New resource allocation algorithms:** another key challenge of C-RAN is the assignment of computing and radio resources shared among multiple cell sites. Network operators should investigate new approaches to determine the best strategies to assign heterogeneous antennas demands to the available edge data centers when satisfying hard latency requirements. An optimal assignment between RRHs and BBUs enables to achieve resource utilization gains by reducing the number of edge data centers used to satisfy antennas demands. This will also minimize the network costs including CAPEX and OPEX. This exciting research challenge .
- **Inter-cell interference reduction:** in C-RAN architecture, each BBU pool should be able to support 10 to 1000 RRHs and provide optimal and joint baseband processing of antennas demands. Moreover, network operators need to increase the density of cells by deploying more antennas in order to meet the growing number of end-users' demands. This requires to investigate new algorithms to reduce inter-cell interference while guaranteeing the full network coverage.
- **BBU functions placement:** the centralization of RAN functions in BBU pools allows capitalizing on computational gain and improving mobile network functions, e.g. scheduling and flow control. Nevertheless, the processing of RAN functionalities in a centralized location increases the fronthaul data rate demands and requires strict latency requirements. Therefore, there is a need for addressing the trade-off between RAN functions centralization and transport requirements by finding the optimal placement of baseband functions in C-RAN architecture.
- **Virtualization:** In addition to the centralization of baseband processing, network virtualization is an important technique for the realization of C-RAN architecture. In fact, virtualization decouples the computing resources from the physical hardware and creates new virtual entities called Virtual Machines (VMs) which are responsible for handling BBU functions in each centralized data center (for more details, see and ). Recent efforts investigated new software solutions to implement virtualized RAN. In fact, authors in and propose a new software platform called OpenAirInterface (OAI), which is an open-source Software Defined Radio (SDR) implementation for 4G/5G networks including both RAN and Evolved Packet Core (EPC) functionalities. This challenge has been very well studied in the literature (see for instance [5], [6] and [7]) and this is not in the scope of our work.

## 1.6 C-RAN and 5G

The fifth generation (5G) cellular network is a new paradigm of cellular technologies mainly consists of three main features[8],

1) millimeter wave spectrum, 2) ultra-densification, and 3) massive multiple-input-multiple-output (MIMO). A large number of different use cases such as applications of the Internet of things (IoT) as well as machine-type communication (MTC), direct device-to-device (D2D) communication will integrate into 5G networks to improve user experience and network capacity. In addition, controlling and coordination among multi-cell, multi-users with distinct use cases require a new infrastructure for 5G networks. In 5G networks, a single layer of macro cell based traditional wireless network will change to densely deployed small cells on top of the macro cell layer. Recently, cloud-RAN (CRAN) has been considered as an enabling technology for 5G network where baseband processing is managed in a centralized pool, called baseband unit (BBU) pool.

The key idea of C-RAN is to pool the baseband units from multiple base stations to a centralized BBU pool. In C-RAN, the pool of BBUs works like servers to process requests from users in a centralized, cooperative, and coordinated way. Furthermore, centralized and cloud-based BBU pools can share resources, mitigate interference, manage mobility among users. The major benefits of C-RAN over conventional RAN are that C-RAN architecture reduces capital expenditure (CAPEX) and operating expenditure (OPEX) cost as well as supports scalability and flexibility of further deployment of small cells in terms of deployment of remote radio heads (RRHs). Figure 4 depicts a small cell-based C-RAN architecture where RRHs are responsible for RF signal transmission from/to users in the small cell and to/from BBU pool through fronthaul links. To satisfy the demand for large bandwidth and data rate, the optical fiber is generally considered as an ideal fronthaul link for C-RAN, whereas wired and wireless links support C-RAN backhaul. There are several challenges associated with C-RAN. For example, the optimization issues of fronthaul include RRH deployment; BBU-RRH mapping, BBU-RRH function visualization, BBU allocation etc. are the major challenging tasks in C-RAN networks. Resource allocation is another challenging task in C-RAN. Generally, two types of resources are considered for allocation: 1) IT resources (e.g., computing servers or BBU, memory, GPU etc.) for computation and 2) wireless resources (e.g., bandwidth) for transmission. The authors in [1] proposed a location-specific energy-efficient resource allocation in C-RAN, where computation tasks are executed in the devices or the cloud depending on the overall power budget. The framework for processing base stations in to a data center is proposed. Similarly, the authors

considered bin packing scheme to match processing requirements to computing servers with the aim to minimize the number of servers or bin to be used. the authors studied energy-efficient resource allocation in queue-aware multimedia heterogeneous C-RAN, where CRAN maintained a queue for each RRH user. However, the round trip time (RTT) or response time (RT) requirement has not been studied in the resource allocation literature. The RTT or RT is an important QoS parameter for delay sensitive applications.

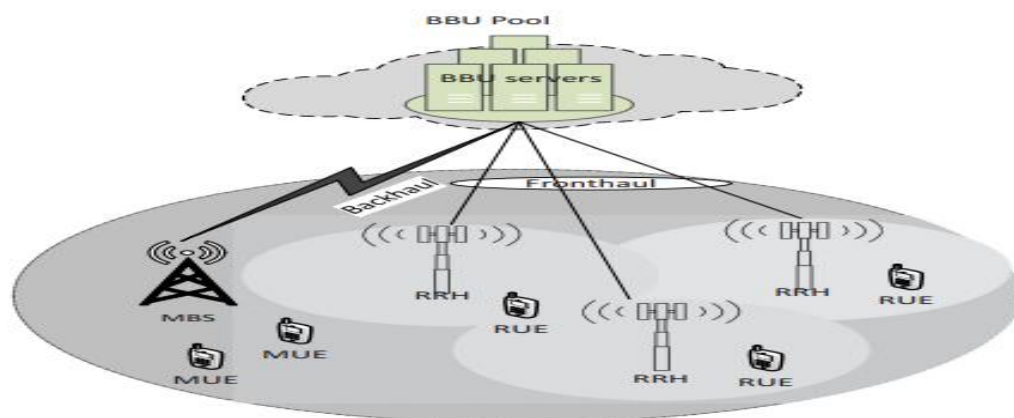

Figure 1.4: Small cell-based C-RAN architecture for 5G networks

## 1. Conclusion

In this work, we addressed the problem of service mode in Cloud Radio Access Networks (CRANs), a new network paradigm to address challenges in 5G networks. We have discussed that in order to take advantage of this network model, an efficient service mode scheme is mandatory to meet strict latency requirements, we mentioned the concept of wireless access network, its components RAN and types of radio access networks (RAN), and we touched on the architecture of C-RAN, the benefits of C-RAN and some of its disadvantages C-RAN And the challenges of C-RAN and finally the relationship between C-RAN and 5G.

**Chapter2**  
**C-RAN optimization:**  
**Mathematical background and state-of-the-art**

## Chapter-2

### C-RAN optimization:

#### Mathematical background and state-of-the-art

### 1. Introduction

Network operators are investigating new algorithms for resource allocation problems to enable and facilitate the deployment of the C-RAN architecture. Total optimization is one of the most effective approaches to addressing such issues. In the first section of this chapter, we describe some of the previous work, studies, research, and findings of researchers in relation to our research. In the second section, we touched on presenting an in-depth analysis system model, including the network model and the energy model.

#### 1.1 Related work

In the last few years, RAN is attracting more and more researchers.. Sun et al. [14] integrates NFV, software-defined radio (SDR), and SDN for 4G/5G networks, and identifies C-RAN as a core component of future 5G networks. Therefore, a lot of work has recently been put into this area [9, 15-17]. C-RAN is energy efficient by centralizing the BBU and enabling dense RRH deployment. He and others. [9] Derives upper and lower bounds on the traversal downlink capacity that can be achieved in C-RAN. On the other hand, pioneering researchers have also investigated how to explore the flexibility afforded by the separation of BBU and RRH. Liu et al. [15] discussed reconfigurable backhaul in C-RAN, which allows one-to-many mapping between RRHs and BBUs, enabling dynamic activation of BBUs and energy saving. A study by Sundaresan et al. also supports this concept. in [13]. Some recent efforts are mainly devoted to infrastructure sharing and spectrum sharing.

As described in [18], some recent efforts have focused on infrastructure and spectrum sharing. Due to the great advantages in network flexibility and power efficiency, some recent studies on energy efficiency in C-RAN have also contributed. Sabella et al. [10] discusses the energy efficiency benefits of C-RAN theoretically by introducing a generalized overall performance model that considers RRH, BBU and backhaul link power consumption. Alhumima et al. [12] records the power consumption of individual components and examines the impact of various parameters, such as B. number of antennas and system bandwidth, on the energy efficiency of C-RAN. Suryaprakash et al.[11] show that C-RAN requires approximately 10% to 15% less capital expenditure persquare kilometer than traditional LTE networks. To optimize the C-RAN energy efficiency, Tang et al.

[19] investigate how to adjust the BBU process rate according to the traffic demand. Kong et al. [16] construct an energy-efficiency BBU cluster reference tested referred as eBase for C-RAN concept verification and performance evaluation. Pompili et al. [17] propose a demand-aware virtual base stations resizing scheme to adapt to the demand fluctuation of the cellular networks.

Furthermore, these concepts and schemes for optimizing resource allocation in C-RAN can be extended to develop software-defined networking (SDN) and network function virtualization (NFV) solutions for C-RAN.

Unfortunately, the traditional 5G C-RAN architecture is not yet able to cope with massive network demands. In conclusion, most existing resource allocation schemes in C-RAN do not yet fully exploit the concept of centralized virtual base stations. Resource allocation issues for large RRHs and BBUs still need to be considered.

Reference	year	Objet	Algorithm
[9]	2014	To optimize the flexibility afforded by the separation of BBU and RRH.	Study of the problem of deriving differential strength analytical limits for cell edge Distributed Antenna Systems (DAS) users in cloud radio access. Networking (C-RAN) under low signal and noise (SNR) conditions by focusing on downlink amplitude. Which is the user equipment reception (UE) capacity of The signal is transmitted simultaneously by $N > 1$ cells.
[10]	2015	To optimize introducing a generalized overall performance model that considers RRH, BBU.	It studies aspects of energy efficiency and related benefits From implementing RANaaS (using commodity hardware) as an evolution of LTE-Advanced Networks toward 5G infrastructure. In fact, from the point of view of the future definition of 5G systems.

[11]	2015	To optimize the C-RAN energy efficiency.	He studies a theoretical framework that enables this Calculate the network deployment cost (similar to using different spatial point operations). After that, the obtained framework is used with Complex model enables information computation Network processing costs, to compare the cost of deployment Cloud-based network versus traditional LTE network, And to analyze why it is more economical. Using This Framework and typical budget.
[12]	2016	to optimize the power consumption of individual components and examines the impact of various parameters	Propose a composite, linear, and specific PM, which explores the individual components relevant to computer analysis, particularly for a software-defined cloud radio access network (SDC-RAN) Architecture. The model determines the energy efficiency (EE) by capturing the computer of individual components.
[13]	2013	to optimize to infrastructure sharing and spectrum sharing.	FluidNet Proposal - A scalable and lightweight framework to realize the full potential of C-RAN. FluidNet deploys logically reconfigurable forward spaces to implement appropriate transport strategies in

			different parts of the network.
[14]	2015	identifies C-RAN as a core component of future 5G networks	This article suggests, Network Function Virtualization (NFV), Software Defined Radio (SDR), and Software Defined Network (SDN). In particular, we are investigating both existing standards And potential additions to 4G / 5G mobile networks, followed by a few open.
[15]	2013	enabling dynamic activation of BBUs	Design Implementation of the first OFDMA-based C-RAN test bed with a Reconfigurable hitch allows 4 oversized units to connect flexibly With 4 RAUs using fiber optic technology.
[16]	2013	energy saving construct and performance evaluation.	He is developing a BBU block test, eBase, into Integrates multiple isolated BBUs into a virtual BBU and Then provide the unified baseband resource pool for the RAN. Present Engineering and implementation of eBase in detail.
[17]	2015	propose a demand-aware virtual base stations.	Study of the stability problem of a nonlinear Kirchhoff series with nonlinear limitscontrol. Nonlinear boundary control is the negative feedback of the tangential velocity of the

			chain atOne end, which meets sector constraints. Using the integral type multiplier method, we created The apparent absolute exponential stability of the Kirchhoff series system.
[18]	2016	to optimize on infrastructure and spectrum sharing	The Karnaugh-map-like Embedding Algorithm (KEA) ,he extend the classical WSRM problem to the QWSRM problem, and then propose a BnB solution for the latter.
[19]	2015	to optimize adjust the BBU process rate according to the traffic demand	<b>Algorithm 1</b> BnB algorithm for QWSRM problem. <b>Algorithm 2</b> Iteratively WMMSE approach for the ESUM problem. <b>Algorithm 3</b> Shaping-and-Pruning Algorithm. BnB algorithm for QWSRM problem Discrimination The problem of allocating resources across layers as a mixed integer Nonlinear programming (MINLP), which jointly studies flexible service scaling, RRH selection, and common beam forming.

Table1: Related work

## 2. System model

In this section, we introduce the system model, including both network model and energy model [22]. For the conveniences of the readers, the major notations used in this paper are listed in Table 2. In existing studies, additional integer variables and complex boundary conditions are usually introduced to ensure radial topology in power distribution system planning and operational optimization. A straightforward way to deal with radial constraints is to find all the loops in the power distribution system and make sure that at least one branch of each loop is open. However, an efficient method for all circuits in a power distribution system has still not been found. Based on graph theory, a model for detecting whether an edge-introduced graph of a graph is a ring or a ring group is proposed, and a method for searching all rings in a power distribution system is proposed. All loops in the allocation system are searched in ascending order of the number of edges contained in the loop. The proposed method is formulated as a mixed integer linear programming (MILP) model. The simulation results verify the feasibility and effectiveness of the proposed method [23].

### 2.1 Network model

We consider a general C-RAN network powered by green energy, as shown in Figure 2.1. The main network entities in a C-RAN network are the BBU and RRH, referred to as sets  $B$  and  $R$ , respectively. BBU and RRH are scattered in the network area. Without loss of generality, we assume that both BBU and RRH are connected to each other. That is, the RRH can be served by any BBU in the network. Since the RRH and BBU do not need to be co-located, their association can be freely defined according to various uses. RRH directly serves users within its transmission range. Let  $\lambda_r$  be the arrival rate of communication requests on RRH  $r \in R$ . Each BBU can handle a limited number of workloads, limited by its processing power. We assume that all BBUs are homogeneous and have the same processing power  $\mu_{max}$ .

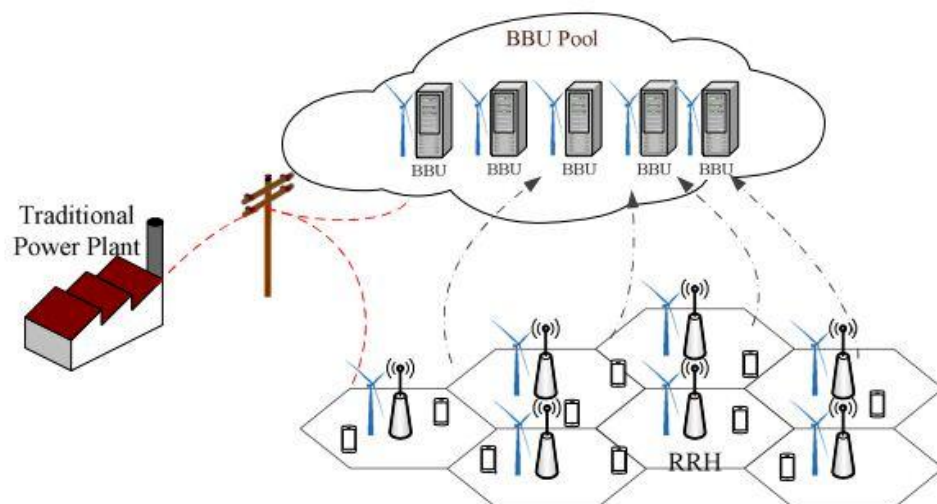

Fig2.1: Green energy powered C-RAN

Table 2 : List of notations

symboles	<u>Description</u>
$B$	The BBU set
$b$	A BBU $b \in B$
$R$	The RRH set
$r$	A RRH $r \in R$
$\lambda_r$	The communication request arrival rate at RRH $r \in R$
$p_b$	Total power consumption at BBU $b \in B$ .
$e_b$	Static power consumption at BBU $b \in B$
$y_b$	Whether BBU $b \in B$ is activated or not
$g_b$	Power generation rate at BBU $b \in B$
$\alpha$	Power consumption and request processing ratio at BBU
$\mu_b$	Total requests at BBU $b \in B$
$p_r$	Total power consumption at RRH $r \in R$
$e_r$	Static power consumption at RRH $r \in R$
$\beta$	Power consumption and

	request processing ratio at RRH
$g_r$	Power generation rate at RRH $r \in R$ or not
$\eta_{xy}$	Power transferring ratio between DERs at network entities $x$ and $y$ , $x, y \in R \cup B$
$x_{rb}$	Whether RRH $r$ is associated with BBU $b \in B$
$\mu_{max}$	The maximum processing capacity at BBU $b \in B$
$p_{ey}$	The brown energy consumed by network entity $y \in R \cup B$

Table 2 : List of notations

## 2.2 Energy model

We adopt an energy model given in [20] where each transmission consumes a unit of energy from the base station. Accordingly, we calculate the total energy consumed at any active BBU  $b \in B$  As

$$p_b = e_b + \alpha \gamma_b \quad (1)$$

Where  $e_b$  is the static energy consumption of BBU  $b$ , regard less of its actual usage once activated and  $\alpha \gamma_b$  is the dynamic power consumption proportional to the workload  $\mu b$  allocated to the BBU with ratio  $\alpha$  similarly, the power consumed by RRH  $r \in R$  can be calculated as

$$p_r = e_r + \beta \lambda_r \quad (2)$$

Where  $e_r$  is the static energy consumption of RRH  $r$ , and  $\beta \lambda_r$  is the dynamic part proportional to the workload  $\lambda_r$  with ratio  $\beta$ . All the network entities are simultaneously powered by both brown energy from traditional power grid and green energy from DERs. The green energy generated at a DER is typically random with certain rate. Without loss of generality, we assume that the energy generated

C-RAN optimization: Mathematical background and state-of-the-art from DER at network entity  $b \in B$  and  $r \in R$  are with rate  $g_b$  and  $g_r$ , respectively. The green energy can be shared among the network entities. As indicated in [21], it is impossible to transfer power between DERs without any loss. The loss may account for 7% of the transferred energy or may even reach 55% in extreme cases. To represent such loss relationship, we use  $\eta_{xy}$ ,  $x, y \in R \cup B$  to denote the efficiently energy transferring ratio between the DERs on different network entities. Specially, we define  $\eta_{xy} \equiv 1$ ,  $\forall x \in R \cup B$  to indicate that no energy loss will be experienced at local DER.

### 3. Problem formulation

#### 3.1 RRH-BBU association constraints

Thanks to the pooling of BBU resources in [22]. The association between BBU and RRH becomes flexible and can be adjusted at runtime. We denote the association relationship between a RRH  $r \in R$  and a BBU  $b \in B$  as a binary variable

$$x_{rb} = \begin{cases} 1, & \text{if RRH is associated with BBU } b, \\ 0, & \text{otherwise} \end{cases} \quad (3)$$

Each RRH must be attached to one BBU by creating a back-haul link between them. Therefore, we have

$$\sum_{b \in B} x_{rb} = 1, \forall r \in R. \quad (4)$$

Note that, from the consideration of energy efficiency, not all BBUs must be activated. To denote such status, we define a binary variable

$$y_b = \begin{cases} 1, & \text{if BBU } b \text{ is active} \\ 0, & \text{otherwise} \end{cases} \quad (5)$$

Consequently, the value of  $x_{rb}$  shall be constrained by  $y_b$  as

$$x_{rb} \leq y_b, \quad \forall r \in R, b \in B, \quad (6)$$

Indicating that a RRH can only be associated with an active BBU, i.e.,  $y_b = 1$ ; otherwise,  $x_{rb}$  is forced to be 0 if  $y_b = 0$ .

#### 3.2 Process capacity constraints

According to the C-RAN communication process, the workload on a BBU is related to its associated RRHs. The total workload  $\mu_b = \sum_{r \in R} x_{rb} \lambda_r$  allocated to BBU  $b \in B$  shall not exceed its processing capacity, i.e.,

$$\sum_{r \in R} x_{rb} \lambda_r \leq y_b \mu_{max}, \forall b \in B \quad (7)$$

#### 3.3 Power supply constraints

To describe the energy consumption transferring relationship, we define variables  $p_{xy}$ ,  $x, y \in R \cup B$  to represent the energy transferring amount from DER at network entity  $x$  to  $y$ . specially, note that we allow  $x = y$ , e.g.,  $p_{xx}$ ,  $x \in R \cup B$ , indicating the amount of green energy from the local DER. When the green energy cannot catch up with the energy demand of a network entity, certain brown energy

C-RAN optimization: Mathematical background and state-of-the-art must be retrieved from the power grid. We use  $p_{ey}$  to denote the amount of brown energy retrieved from the power grid to the network entity  $y$ , which could be either a RRH or a BBU. To ensure the functionality of a network entity, its total energy supply must satisfy its energy requirement. That Is

$$\sum_{r \in R} p_{rb} \eta_{rb} + \sum_{x \in B} p_{xb} \eta_{xb} + p_{eb} \geq y_b e_b + \alpha \sum_{r \in R} x_{rb} \lambda_r, \quad \forall b \in B, \quad (8)$$

And

$$\sum_{r \in R} p_{xr} \eta_{xr} + \sum_{r \in R} p_{br} \eta_{br} + p_{er} \geq e_r + \beta \lambda_r, \quad \forall r \in R, \quad (9)$$

Where  $p_{eb}$  and  $p_{er}$  denote the brown energy retrieved from the power grid to BBU  $b$  and RRH  $r$ , respectively. The green energy transferring amount is limited by the green energy generation rate. Therefore, we have

$$\sum_{x \in RUB} \sum_{y \in RUB} p_{xy} \leq \sum_{r \in R} g_r + \sum_{b \in B} g_b. \quad (10)$$

Our objective to maximize the energy efficiency is equivalent to minimizing the brown energy usage. Taking all the constraints discussed above, we eventually obtain an MILP as.

**MILP:**

$$\sum_{r \in R} p_{er} + \sum_{b \in B} p_{eb}$$

st. : (4), (6), (7) - (10),

$$x_{rb} \in \{0, 1\}, y_b \in \{0, 1\}, \forall r \in R, b \in B$$

$$\sum_{r \in R} p_{er} + \sum_{b \in B} p_{eb}$$

st. : (4), (6), (7) - (10),

$$x_{rb} \in \{0, 1\}, y_b \in \{0, 1\}, \forall r \in R, b \in B.$$

## Conclusion

In this chapter, we investigate a brown energy consumption minimization problem by joint optimization of the RRHBBU association and green energy sharing. We formally describe the problem by MILP and then propose a two phase heuristic algorithm to obtain a sub-optimal solution. The efficiency of our proposed algorithm is extensively verified by the fact it performs much close to the optimal solution and exhibits much advantage over the other two competitors. Our study identifies the advantage of joint optimization of network resources and energy resource in green energy powered C-RAN and will open up more research directions to pursue the high performance efficiency and high-energy efficiency next-generation wireless networks.

## **Chapter 3**

# **Design And Implementation**

## chapter3

# Design And Implementation

## 1. Introduction :

On the practical side, there are many software applications. We have used java because of its ease and simplicity, as it is a common language and we improve its mastery.

### 1.1 Netbeans:

NetBeans IDE was developed at the initiative of Sun Microsystems. It presents everything Characteristics necessary for a quality environment, whether developing Java, Ruby, C/C++ and even PHP.

Net beans is under an open source license, which allows rapid development and deployment Free graphical Swing applications, Applets, JSP/Servlets, J2EE architecture in a highly customizable environment.

NetBeans IDE is based on the powerful core NetBeans platform and you can use it You can also use it to develop your own Java applications and plug in system Powerful, allowing modular IDE. In addition to the full version of the IDE There are different versions of NetBeans focused on one or one platform Precise languages (Java ME, Java: SE + ME + EE, Ruby, C/C++, PHP).

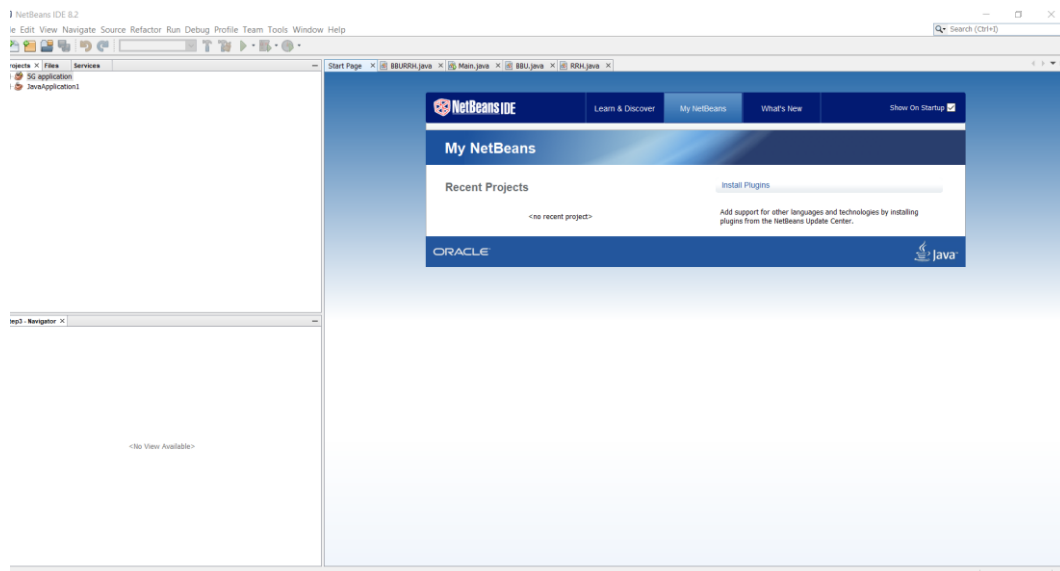

Figure 3.1 NetBeans IDE 8.2

In addition to support for CVS and SubVersion, NetBeans also includes support for Clear Case, Also applies to Mercurial. It also allows deploying web applications instead of Only works with Tomcat and Glassfish included with the "Web Pack", also works with JBoss, WebSphere 6.1, WebLogic 9.

NetBeans Supports Web Application Development with Improvements For editing JSPs, server management and support for the latest version of Tomcat.

Finally, this IDE has a high-quality debugger and an improved graphical interface.

## **1.2 Reminders for Java Architecture:**

The Java language and runtime environment are the result of research work that has been done Developed by Sun .Microsystems in the 1990s as part of the Stealth Project (later renamed the Green Project). The goal is to create a high-level, object-oriented and Inspired by C++, fill the gaps in the management of the latter Storage (Add Garbage Collector) and Programming At the same time (native management of multithreading). The project was originally aimed at the market Thin clients (PDAs, etc.), but repositioned in the early 1990s Network related applications.

The rise and popularity of Java largely depends on the rise of web technologies. Sun's free runtime environment and tools Development over the Internet (compilers) also contributed to The different Subsequent versions of the language and execution environment since version 1.0, Released in 1996 to the latest stable version (1.6) available since 2006. One of the goals of Java is to ensure The same Java program can be used in different environments (UNIX, Windows, Mac, etc.). So Sun decided to develop an execution platform (or environment) Default, virtual machine based. Detailed explanation of the platform architecture in the next section.

## **1.3 General description of the architecture:**

The execution environment of a Java program, shown in Figure 3.2, includes various more or less standardized elements. The figure distinguishes three sets:

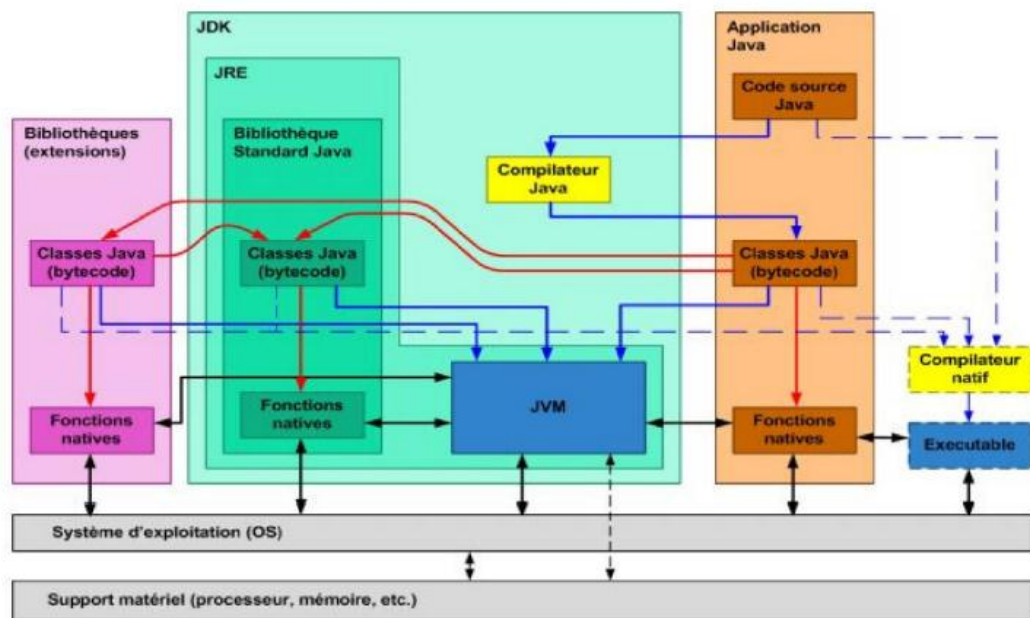

Figure 3.2 The execution environment of a Java programme.

1. Java applications are developed by programmers using the Java language. The application's source code is compiled into an intermediate form: Java byte code. The latter is performed by the Java Runtime Platform.

Applications may also contain native code (in C or C++ for example) to perform operations that cannot be specified in the Java language. However, this type of code is not recommended as it reduces 2. To run Java applications on hardware and software platforms (OS) different, Sun has defined a standard execution platform based on a virtual machine: the JVM (Java Virtual Machine). Besides the JVM, the platform also includes a standard Java library. The minimum set of elements for running a Java application, which includes, among other things, a implementation of the JVM and the standard library, is referred to as JRE (Java Runtime Environment). The JDK (Java Development Kit) is a superset of the JRE for developing Java applications. It includes, in addition the elements of the JRE, the Java compiler which converts the source files (in Java) into class files (in Java byte code).

1. The Java application may also rely on third-party libraries (designated here under the term extension libraries). These are usually provided in the form of class files (bytecode) grouped in archives (JAR). Those libraries can also use native code. Unlike the standard library, these libraries are not part of the runtime platform standard and must be installed separately. They simply allow reuse existing code without necessarily having the source code.

## 2. Implementation

### 2.1 the BBU class:

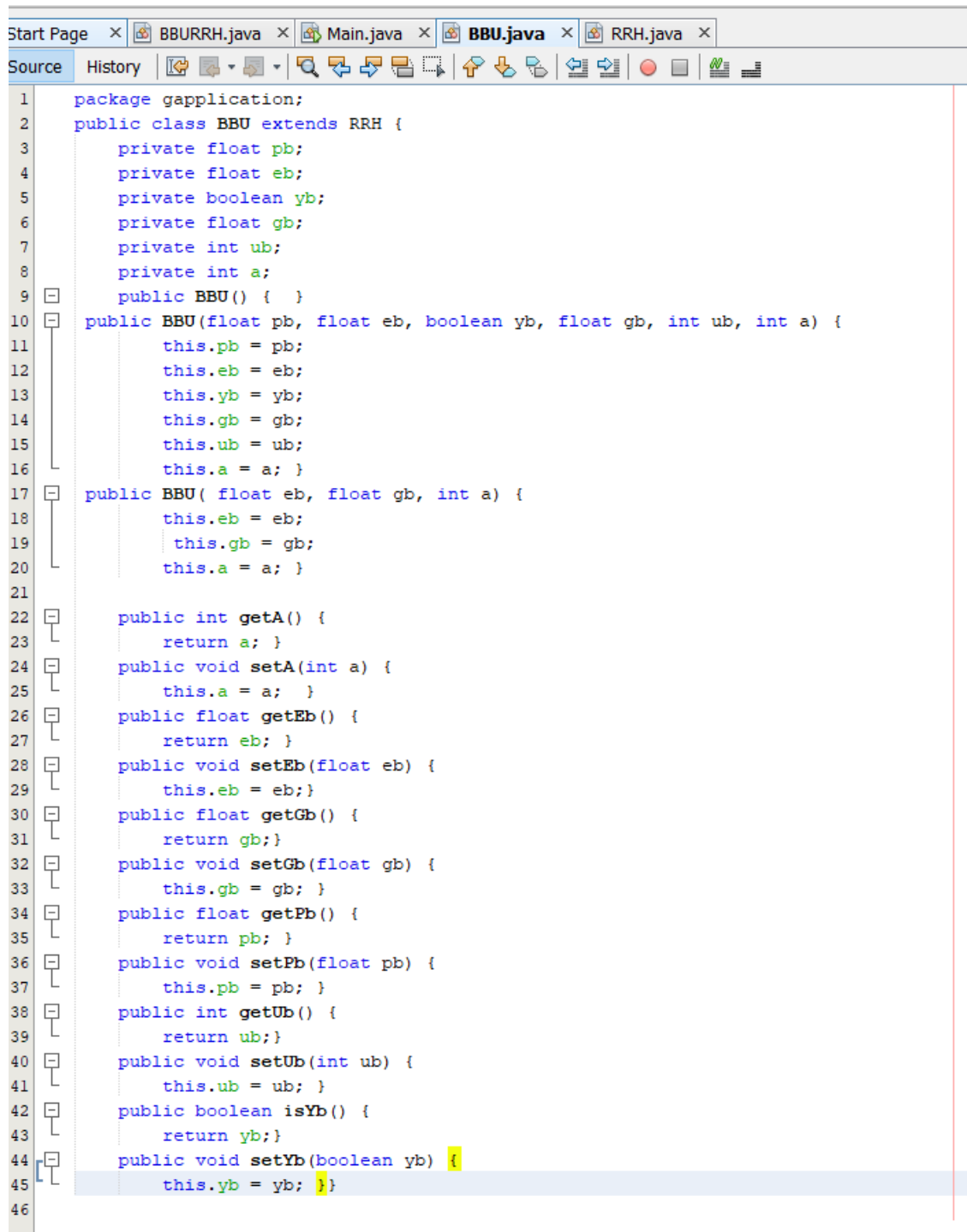

```

1  package gapplication;
2  public class BBU extends RRH {
3      private float pb;
4      private float eb;
5      private boolean yb;
6      private float gb;
7      private int ub;
8      private int a;
9      public BBU() { }
10     public BBU(float pb, float eb, boolean yb, float gb, int ub, int a) {
11         this.pb = pb;
12         this.eb = eb;
13         this.yb = yb;
14         this.gb = gb;
15         this.ub = ub;
16         this.a = a; }
17     public BBU( float eb, float gb, int a) {
18         this.eb = eb;
19         this.gb = gb;
20         this.a = a; }
21
22     public int getA() {
23         return a; }
24     public void setA(int a) {
25         this.a = a; }
26     public float getEb() {
27         return eb; }
28     public void setEb(float eb) {
29         this.eb = eb;}
30     public float getGb() {
31         return gb;}
32     public void setGb(float gb) {
33         this.gb = gb; }
34     public float getPb() {
35         return pb; }
36     public void setPb(float pb) {
37         this.pb = pb; }
38     public int getUb() {
39         return ub;}
40     public void setUb(int ub) {
41         this.ub = ub; }
42     public boolean isYb() {
43         return yb;}
44     public void setYb(boolean yb) {
45         this.yb = yb; }
46

```

Figure 3.3 the BBU class.

For simulate the BBU we try to create class BBU that contain the characteristics as args with the getter and setter methods

## 2.2 The RRH class:

```

1 package gapplication;
2 public class RRH {
3     private float pr;
4     private double er;
5     private boolean yr;
6     private float gr;
7     private int ur;
8     private int b;
9     private int r;
10    public RRH() {}
11    public RRH(float pr, float er, boolean yr, float gr, int ur, int b, int r) {
12        this.pr = pr;
13        this.er = er;
14        this.yr = yr;
15        this.gr = gr;
16        this.ur = ur;
17        this.b = b;
18        this.r = r; }
19    public RRH( double er, float gr, int r) {
20        this.er = er;
21        this.gr = gr;
22        this.r = r; }
23    public int getB() {
24        return b; }
25    public void setB(int b) {
26        this.b = b; }
27    public double getEr() {
28        return er; }
29    public void setEr(float er) {
30        this.er = er;}
31    public float getGr() {
32        return gr; }
33    public void setGr(float gr) {
34        this.gr = gr; }
35    public float getPr() {
36        return pr; }
37    public void setPr(float pr) {
38        this.pr = pr;}
39    public int getUr() {
40        return ur; }
41    public void setUr(int ur) {
42        this.ur = ur;}
43    public boolean isYr() {
44        return yr;}
45    public void setYr(boolean yr) {
46        this.yr = yr;}}
47

```

Figure 3.4 The RRH class

We do the same for simulate RRH with the specific args and getter and setter method.

## 2.3 The BBURRH class:

```

1 package gapplication;
2 public class BBURRH {
3     BBU[] bbus;
4     RRH[] R;
5     static boolean [] x_rb=new boolean[15] ;
6     //phase one
7     public static BBU[] sort(BBU[] bbus, int n) {
8
9         for( int i=1; i< n;i++){
10            int j = i;
11            BBU a = bbus[i];
12            while ((j > 0) && (bbus[j-1].getGb() >a.getGb())){
13                bbus[j] = bbus[j-1];
14                j--;
15            }
16            bbus[j] = a;
17        }
18        return bbus;
19    }
20    private static void initialise(boolean [] x){
21        for( int j =0; j<15; j++){
22            x[j] = false;
23        }
24    }
25    public static void step3(BBU[] bbu, RRH[] rrh, int n){
26        initialise(x_rb);
27        for( int i =0; i<n; i++){
28            for( int j =0; j<n; j++){
29                if(bbu[i].getGb()== rrh[j].getGr()){
30                    x_rb[i] = true;
31                }
32                if(bbu[i].isYb()){
33                    bbu[i].setYb(true);
34                }
35                //update the accumulated workload ub and the remain process capacity on baccording to r
36            }
37        }
38    }
39    //phase2
40    public void phase2(BBU[] bbu, RRH[] rrh, int n){
41        for( int i=0;i<n;i++){
42            //calculate surplus energy
43            for( int j=0;j<n;j++){
44                float min = bbu[i].getPb()+ rrh[j].getPr();
45            }
46        }
47    }
48 }

```

Figure 3.5 The BBURRH class.

In this class we try to implement the necessary methods and args that work with code with deferent type of constructors Our methods is simulation for two-phase algorithm:

1. sort method :

The main idea of this method is for sort the bbu units depending on its energy (parameter gb).

2. step two:

After we get bbu sorted we try to taste its activity According to the idea of this algorithm the bbu could be activated if its energy values could be in rrh table and this exactly what we did in our simulation.

## 2.4 The main class:



```

1  package gapplication;
2
3  public class Main {
4
5      public static void main(String[] args) {
6
7
8          BBU[] b = new BBU[15];
9          RRH[] r = new RRH[40];
10         double randi;
11         for (int i = 0; i < 15; i++) {
12             randi = Math.random();
13             b[i] = new BBU(1, Math.round(randi * 15), 2);
14         }
15         for (int i = 0; i < 40; i++) {
16             randi = Math.random();
17             r[i] = new RRH(0.1, Math.round(randi * 40), 4);
18         }
19
20         BBU[] bbusorted = BBURRH.sort(b, 15);
21
22         BBURRH.step3(b, r, 15);
23
24         System.out.print("BBU\t RRH\t isBBUinRRH \n");
25         for (int i = 0; i < 15; i++) {
26             System.out.print(bbusorted[i].getGb()+"\t"+r[i].getGr()+"\t"+ BBURRH.x_rb[i)+"\t" + "\n");
27         }
28         System.out.print("*****\n");
29         for (int i = 0; i < 40; i++) {
30             System.out.print("rrh:\n " + r[i].getGr() + "\n");
31         }
32     }
33     System.out.print("*****\n");

```

Figure 3.6 the main class.

We create a table of `bbu` and a table of `rrh`. Those two tables have random values depending on our interval  $B=15; R=40$ . We sort the `bbu` table and we test if there is any active `bbu`. We could get to this step different results in multiple execution.

## 2.5 Results

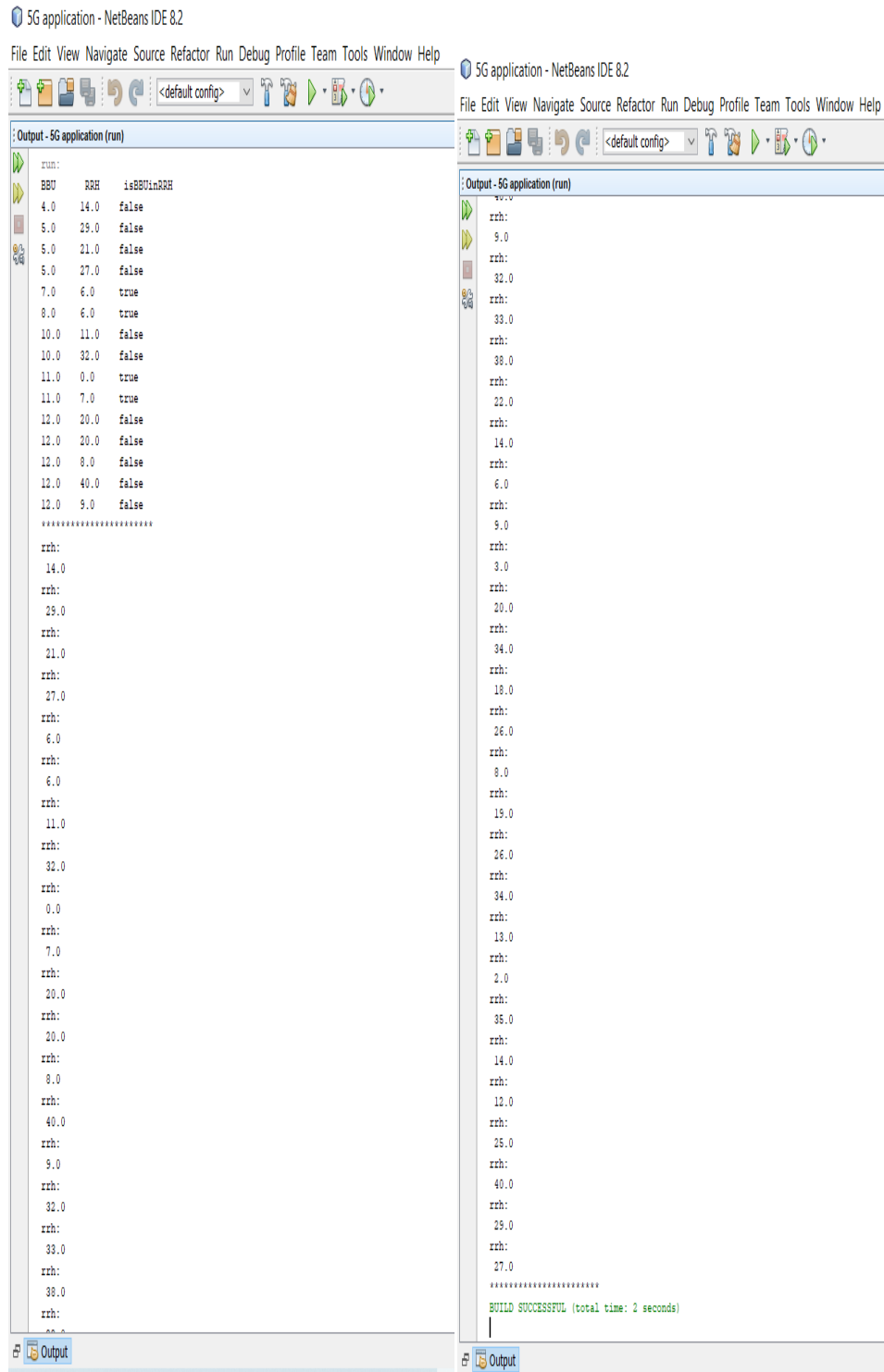

Figure 3.7 the result.

The result is output by multiple process, first step is generating the bbu table and the rrh table randomly on the interval  $B = 15$ ;  $R = 40$ . The second step is by sorting the bbu table, next, we test for each value in bbu table, if it exists in rrh table then it's active, else it's not.

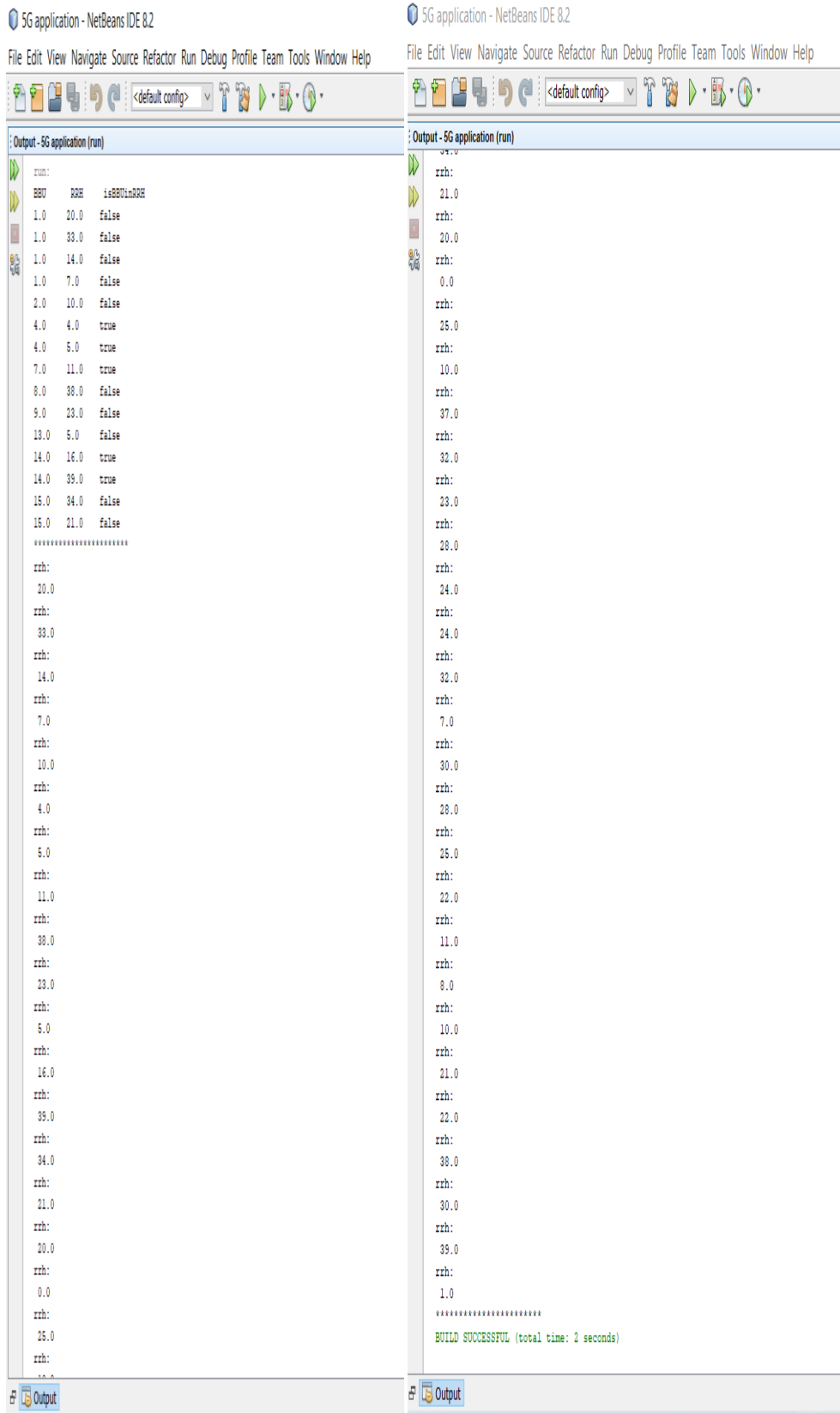

Figure 3.8 the result2.

## Conclusion

In this area of our research, we have addressed the problem of resource allocation in the CRAN environment by implementing and evaluating an existing algorithm that is scalable and low-cost optimization technique. In fact, C-RAN is a promising network for 5G cellular network architecture to meet different business needs and handle new business opportunities. C-RAN Network costs is expected to be reduced and resource efficiency should be increased. Therefore, we investigated the problem of optimizing the RRH-BBU allocation in C-RAN.

Therefore, the problem is formulated by MILP and then a heuristic algorithm has been used to obtain a suboptimal solution. The efficiency of this algorithm is universal. This is confirmed by the fact that it is close to the optimal solution and has many advantages over other solutions. Our research identifies hinge benefits optimize network resources.

## Bibliography

- [1] <https://www.redhat.com/en/topics/5g-networks/what-is-radio-access-network>., consulté le : 01/02/2022
- [2] <https://www.techtarget.com/searchnetworking/definition/radio-access-network-RAN>, consulté le : 01/02/2022.
- [3] NieziMharsi. Cloud-Radio Access Networks : design, optimization and algorithms. Networking and Internet Architecture [cs.NI]. Université Paris-Saclay, 2019. English. ffNNT : 2019SACLTO43ff. fftel-02373002ff
- [4] Md. Farhad Hossain<sup>1</sup>, AymanUddin Mahin<sup>2</sup>, Topojit Debnath<sup>3</sup>, FarjanaBinte Mosharrof<sup>4</sup> and KhondokerZiaul Islam<sup>5</sup> ,Department of Electrical and Electronic Engineering, Bangladesh University of Engineering and Technology, Dhaka-1205, Bangladesh Email: 1mfarhadhossain@eee.buet.ac.bd,
- [5] X. Wei, H. Liu, Z. Geng, K. Zheng, R. Xu, Y. Liu, and P. Chen, “Software Defined Radio Implementation of a Non-Orthogonal Multiple Access System Towards 5G,” *IEEE Access*, vol. 4, pp. 9604–9613, 2016.
- [6] S. Sun, M. Kadoch, L. Gong, and B. Rong, “Integrating network function virtualization with SDR and SDN for 4G/5G networks,” *IEEE Network*, vol. 29, pp. 54–59, May 2015.
- [7] Z. Feng, C. Qiu, Z. Feng, Z. Wei, W. Li, and P. Zhang, “An effective approach to 5G: Wireless network virtualization,” *IEEE Communications Magazine*, vol. 53, pp. 53–59, Dec 2015.
- [8] LilatulFerdouse Department of Electrical and Computer Engineering Ryerson University Toronto, Canada lilatul. WaleedEjaz Department of Electrical and Computer Engineering Ryerson University Toronto, Canada
- [9] He Y, Dutkiewicz E, Fang G, Shi J (2014) Differential capacity bounds for distributed antenna systems under low SNR conditions. In: 2014 IEEE International conference on communications, ICC 2014, pp 5550–5554.
- [10] Sabella D, De Domenico A, Katranaras E, Imran MA, Di Girolamo M, Salim U, Lalam M, Samdanis K, Maeder A (2015) Energy efficiency benefits of RAN-as-a-service concept for a cloud-based 5G mobile network infrastructure. *IEEE Access* 2:1586–1597.

- [11]Suryaprakash V, Rost P, Fettweis G (2015) Are heterogeneous cloud-based radio access networks cost effective? *IEEE J Selected Areas Commun* 33(10):2239–2251.
- [12]Alhumaima RS, HS Al-Raweshidy (2016) Evaluating the energy efficiency of software defined-based cloud radio access networks. *IET Commun* 10(8):987–994.
- [13]Sundaresan K, Arslan MY, Singh S, Rangarajan S, Krishnamurthy SV (2013) FluidNet: a flexible cloud-based radio access network for small cells. In: *Proceedings of the 19th annual international conference on mobile computing & networking - MobiCom '13*. ACM Press, New York, p 99.
- [14].Sun S, Kadoch M, Gong L, Rong B (2015) Integrating network function virtualization with SDR and SDN for 4G/5G networks. *IEEE Netw* 29(3):54–59
- [15]Liu C, Sundaresan K, Jiang M, Rangarajan S, Chang GK (2013) The case for reconfigurable backhaul in cloud-RAN based small cell networks. In: *Proceedings - IEEE INFOCOM*, pp 1124– 1132.
- [16]Kong Z, Gong J, Xu CZ, Wang K, Rao J (2013) EBase: a baseband unit cluster testbed to improve energy-efficiency for cloud radio access network. In: *IEEE International conference on communications*, pp 4222–4227.
- [17]). *Ad Hoc Netw* 30:128–143Pompili D, Hajisami A, Viswanathan H (2015) Dynamic provisioning and allocation in cloud radio access networks .
- [18] Baliosian J, Serrat J, Gorricho J-I (2016) Resource slicing in virtual wireless networks. *A Survey* 4537(c):1–14
- [19] Tang J, Tay WP, Quek TQS (2015) Cross-layer resource allocation with elastic service scaling in cloud radio access network. *IEEE Trans WirelCommun* 14(9):5068–5081.
- [20]. Li D, Saad W, Guvenc I, Mehdodniya A, Adachi F (2015) Decentralized energy allocation for wireless networks with renewable energy powered base stations. *IEEE Trans Commun* 63(6):2126–2142.
- [21] Gkatzikis L, Iosifidis G, Koutsopoulos I, Tassiulas L (2015) Collaborative placement and sharing of storage resources in the Smart Grid. In: *2014 IEEE international conference on Smart Grid communications, SmartGridComm 2014*, pp 103–108.
- [22] Song Guo<sup>1,2</sup> · Deze Zeng<sup>3</sup> · Lin Gu<sup>4</sup> · Jiangtao Luo<sup>2</sup>,(2018) When Green Energy Meets Cloud Radio Access Network: Joint Optimization Towards Brown Energy Minimization.Published online: 15 February 2018© Springer Science+Business Media, LLC, part of Springer Nature 2018.

[23][https://www.researchgate.net/publication/359398411\\_Searching\\_Loops\\_in\\_Distribution\\_Systems\\_A\\_MILP-Based\\_Method](https://www.researchgate.net/publication/359398411_Searching_Loops_in_Distribution_Systems_A_MILP-Based_Method), consulté le : 05/04/2022.

## Abstract:

Wireless networks have experienced rapid growth over the past few decades. Various advanced wireless technologies have been suggested. To keep up with the ever-increasing demands of various communications, Cloud Radio Access Network (C-RAN), Schemes have been used to separate the baseband processing unit (BBU) from the remote radio head (RRH) in another. On the other hand, it is widely recognized that, due to heavy usage, huge energy consumption is increased. Cellular network. Therefore, reducing power grid energy consumption has become a hot topic. To fight limitations of traditional grids, smart grids with emphasis on distributed energy sources (DER) and bidirectional Energy sharing, advocated for powering wireless networks. In this work, we are motivated to study a common RRH-BBU Linking and energy sharing problems for minimizing brown energy consumption in C-RAN with green power. That The problem is expressed in MILP (Mixed Integer Linear Programming) form. Handling Computational Complexity To solve MILP, a two-stage heuristic polynomial-time algorithm by using and evaluated using extensive simulations study.

Keywords: Cloud RAN; green energy; MILP; RRH-BBU.

### المخلص:

شهدت الشبكات اللاسلكية نموًا سريعًا خلال العقود القليلة الماضية. تم استعمال العديد من التقنيات اللاسلكية المتقدمة. لمواكبة المتطلبات المتزايدة باستمرار للاتصالات المختلفة، شبكة الوصول إلى الراديو السحابي (C-RAN)، تم استعمالنا مخططات لفصل وحدة معالجة النطاق الأساسي (BBU) عن رأس الراديو البعيد (RRH) في جهة أخرى، من المسلم به على نطاق واسع أنه بسبب الاستخدام الكثيف، يزداد استهلاك الطاقة الهائل. شبكه خلوية. لذلك، تقليل طاقة شبكة الكهرباء أصبح الاستهلاك موضوعًا ساخنًا. لمحاربة قيود الشبكات التقليدية والشبكات الذكية مع التركيز على مصادر الطاقة الموزعة (DER) ومشاركة الطاقة ثنائية الاتجاه، والتي تمت الدعوة لها لتشغيل الشبكات اللاسلكية. في هذا العمل، نقوم بدراسة مشاكل ربط ومشاركة الطاقة RRH-BBU الشائعة لتقليل استهلاك الطاقة البنية في C-RAN مع الطاقة الخضراء. يتم التعبير عن المشكلة بصيغة MILP (البرمجة الخطية المختلطة الصحيحة). معالجة التعقيد الحسابي لحل MILP، تم استعمال وتقييم خوارزمية إرشادية متعددة الحدود للوقت من مرحلتين باستخدام دراسة المحاكاة المكثفة.

الكلمات الرئيسية: Cloud RAN؛ الطاقة الخضراء؛ ميل؛ رأس الراديو البعيد؛ وحدة

معالجة النطاق الأساسي.

## Résumé:

Les réseaux sans fil ont connu une croissance rapide au cours des dernières décennies. De nombreuses technologies sans fil avancées ont été utilisées. Pour suivre le rythme des demandes toujours croissantes de différentes communications, Cloud Radio Access Network (C-RAN), nous avons utilisé des schémas pour séparer l'unité de traitement de bande de base (BBU) de l'en-tête radio distant (RRH). l'énorme puissance la consommation augmenter. Réseau cellulaire. Par conséquent, la réduction de la consommation d'énergie du réseau électrique est devenue un sujet brûlant. Combattre les limites des réseaux traditionnels et intelligents en mettant l'accent sur les sources d'énergie distribuées (DER) et le partage d'énergie bidirectionnel, qui ont été réclamés pour alimenter les réseaux sans fil.

Dans ce travail, nous sommes ravis d'étudier les problèmes communs de liaison et de partage d'énergie RRH-BBU a fin de réduire la consommation d'énergie structurelle dans C-RAN avec de l'énergie verte. Le problème est exprimé en MILP (Mixed Integer Linear Programming). Abordant la complexité de calcul de la solution MILP, un algorithme heuristique polynomial temporel à deux étapes a été utilisé et évalué à l'aide d'une étude de simulation intensive.

Mots-clés: Cloud RAN; énergie verte; MILP; RRH-BBU.