

Real-Time Eddy Current Measurement of Aeronautical Construction Material Coating Thickness

Abdelhak. Abdou^{1,2}, Tarik. Bouchala³, Bachir. Abdelhadi^{4,5}, Amor. Guettafi^{4,5}, Azzeddine. Benoudjit⁴

¹ Electrical Engineering Department, Mohamed Boudiaf University, M'sila (2800), Algeria

² Research Laboratory on the Electrical Engineering, Faculty of Technology, Mohamed Boudiaf University, M'sila (2800), Algeria

³ Electrical Engineering Department, Mohamed Boudiaf University, M'sila (2800), Algeria

⁴ Electrical Engineering Department, Batna2 University. Batna (0500), Algeria

⁵ Laboratory of Electric Traction Systems (LSTE), Batna2 University, Batna (0500), Algeria

Corresponding Author Email: abdelhak.abdou@univ-msila.dz

<https://doi.org/10.18280/i2m.xxxxxx>

ABSTRACT

Received:

Accepted:

Keywords:

Eddy Current Sensor; Coating Thickness; Inverse Problem; coupled circuits method; metal sheet.

In this paper, a new method of contactless coating thickness measurement of aeronautical construction materials such as Al, AU4G, Ti and Inox 304L is developed. This method is essentially based on the association of the coupled circuits forward model with a new and efficient research algorithm. The proposed method is very fast because few second are sufficient to calculate coating thickness, for a starting research interval of [0.1mm-3mm] to and tolerance of 1nm. So, the study of the calculation time according to the starting interval width has showed that an optimal choice has to be made in order to improve the rapidity while preserving its precision. Considering its rapidity and its simplicity of implementation, this method is more adapted, for automated industrials applications.

1. INTRODUCTION

In the field of aeronautics, aircraft are periodically subject to inspection and maintenance operations, as in the case of Algeria's aircraft maintenance division. In the nondestructive testing workshop, eddy current technique is widely used for evaluating and controlling the relevant parts of aircraft. Among these applications, the non-conductive coating thickness measurement, [1]. So, dielectric coatings such as paint and varnish are used in aeronautic construction for heat-shielding, heat resisting, anticorrosive, [2]. In industrial automatic application, several iterative inversion methods are used to accomplish this objective. In general, the flowchart constitutes an iteration buckle containing the forward model associated to an inversion algorithm [3-4]. We recall that analytical forward method of Dodd and Deeds gives the exact solution but the skin and the proximity effects in the exciting coil turns are neglected, [5]. On other hand, the finite element method (FEM) is applicable to any complex devices without restrictions, but it's relatively slow in comparison to the analytical ones. For this reason, our effort is mainly focused on the application of the coupled electric field method (CEFM) that we have recently developed and performed because it is fast and can take into consideration both skin and proximity effects [6]. In this paper, our goal is to associate the coupled circuit method and a new deterministic optimization method that we have recently developed for measuring the non-conductive coating thickness of Al, AU4G, Ti and Inox-304L sheet metals, [7].

A coating thickness meter is a scientific instrument for measuring the thickness of layers on a base material called substrate or support. So, coating thickness measurement is a very useful discipline in materials science. Thickness of conductive or nonconductive coating thickness is one of the essential criteria for characterizing a coating; a minimum layer thickness on a part is required to ensure physical, electrical, mechanical or aesthetic properties, [1]. Typical application areas are the automotive, microelectronics and aeronautics industries. In aircraft and aeronautical domains, several sheet metal materials such as Al, AU4G, Ti and stainless steel 304L with coating layer are used to ensure resistance to mechanical thermal and chemical constraints, Fig.1.

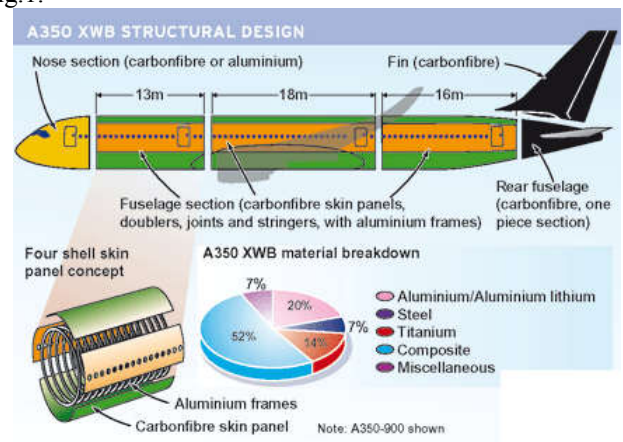

Figure 1. Aeronautic construction materials.

2. COATING THICKNESS MEASUREMENT IN AERONAUTIC

The plane cockle is made, in majority, of aluminium alloys formed by aluminium mixed respectively with copper and zinc.

Aluminium is used in general because its volume density is very weak, what presents an advantage in aeronautics. Indeed, more the plane is light, it consume less. Aluminium is also very appreciated its good resistance for corrosion. Aluminium is easily malleable what makes the construction of different more easier, [8, 9].

3. STUDIED DEVICE

In our study, the metal presents a flat surface with thin nonconductive coating. In a concrete study, when using eddy current to measure non conductive coating thickness, it is important to ensure that the other factors are kept under control. A pancake-type probe formed of coil used whose axis is perpendicular to the surface of the tested piece, [10, 16]. This type of sensor is used for flat surface inspections, Fig.2. In our study, we neglect the parameters that affect commonly coating thickness measurement such as: edge effects, curvature, cleaning of surface and perpendicularity of the sensor probe.

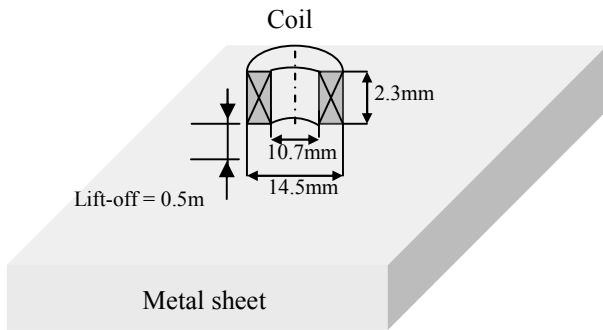

Figure 2. Studied device.

The geometrical and physical characteristics are given in Table 1.

Table 1. Characteristics of the studied device.

Coil	
Current intensity	0.04A
Frequency	10kHz
Inner radius	5.35 [mm].
Length	2.35 [mm].
High	2.3 [mm].
Plate	
Thickness	2 [mm].
Electric conductivity	That of Al, Inox 304L, Ti
Magnetic permeability	1

4. COUPLED ELECTRIC FIELD MOTHOD

The electromagnetic phenomenon intervening in eddy current non-destructive systems is described by the following generalized punctual equations, [9-15].

$$\frac{2\pi r(p)}{\sigma} J(p) + \mu_o r(p) G(p, q) \frac{dI(q)}{dt} = u(p) \quad (1)$$

$$G(p, q) = \sqrt{\frac{r(p)}{r(q)}} E(k(p, q)) \quad (2)$$

$$E(k) = \frac{(2 - k^2)E_1(k) - 2E_2(k)}{k} \quad (3)$$

$$k(p, q) = \sqrt{\frac{4r(p)r(q)}{(r(p) + r(q))^2 + (z(p) - z(q))^2}} \quad (4)$$

Where:

$G(p, q)$ is called Green's function and represents the response of the system at a point $p(r, z)$ to Dirac's distribution located at a point q .

$E_1(k)$ and $E_2(k)$ are respectively the first and the second species of the Legendre elliptic function, [9].

ω is the pulsation.

$r(p)$ and $r(q)$ are the radial coordinate of the point p and q respectively.

$z(p)$ and $z(q)$ are the axial coordinate of the point p and q respectively.

Equation (2) expresses the creation of the current intensity $I(p)$ at a point p of electric conductivity $\sigma(p)$ under the influence of the voltage $u(p)$ applied at this point, and the current intensity $I(q)$ situated in q .

The above equations describe only the electromagnetic effect of one point upon another. To realize the electromagnetic contribution of the complete domain Ω upon point p , equation (1) is rewritten in the following form:

$$\frac{2\pi r(p)}{\sigma(p)} J(p) + j\omega\mu_o r(p) \iint_{\Omega} G(p, q) J(p, q) d\Omega = u(p) \quad (5)$$

In our case, we need to express eddy current probe impedance variation caused by the presence of the conductive material, according to its thickness E_c and electric conductivity σ .

The current density $J(p)$ can be expressed according to the electric field $E(p)$ as follows:

$$\begin{cases} J(p) = \sigma(p)E(p) \\ I(p) = s(p)\sigma(p)E(p) \end{cases} \quad (6)$$

$s(p)$ is the cross section of the turn p .

By introducing the transformation of equation set (6), equation (5) leads to equation (7). We have named this latter the generalized coupled electric field equation:

$$2\pi r(p)E(p) + \mu_o r(p) \iint_{\Omega} G(p, q) \sigma(p)E(p) d\Omega = u(p) \quad (7)$$

The next sections will be devoted to the modeling of axi-symmetrical configuration by applying equation (6) on the exciting coil region and equation (8) on the tested conductive piece.

5. GEOMETRICAL MODEL DESCRIPTION

In the present study, the metal sheet is considered as a flat surface with or without a thin nonconductive coating. In fact, the exciting coil of domain Ω_o delivers a sinusoidal magnetic field that induces eddy current in a massive metal sheet of domain Ω_c .

In view of the fact that the system is axially symmetric, the magnetic field calculation is performed only in a half domain.

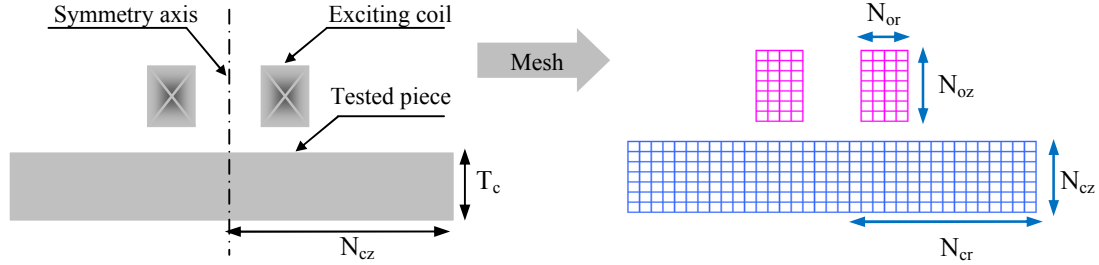

Figure 3. Two-dimensional geometry and meshing.

6. SENSOR EQUATION

The domain Ω is divided into two active regions: the one of the sensor coil is denoted Ω_o while the other region of the piece is denoted Ω_c . The presence of induced currents in the piece influences the source current density J_o . To express this influence, we apply equation (5) to both coil and piece domains respectively.

$$\begin{aligned} \frac{2\pi r_o(p_o)}{\sigma_o(p_o)} J_o(p_o) + j\omega\mu_o r_o(p_o) \iint_{\Omega_o} G(p_o, q_o) J_o(q_o) d\Omega_o + \\ j\omega\mu_o r_o(p_o) \iint_{\Omega_c} G(p_o, q_c) J_c(q_c) d\Omega_c = u(p_o) \end{aligned} \quad (8)$$

According to Figure 2, when the previous domains Ω_o and Ω_c are meshed into N_o and N_c elementary loops respectively and by considering that the sensor is subjected to a total voltage U , equation (8) becomes:

$$\begin{aligned} \sum_{p_o=1}^{N_o} \frac{2\pi r_o(p_o)}{\sigma_o(p_o) S_o(p_o)} I_o + j\omega\mu_o I_o \sum_{p_o=1}^{N_o} r_o(p_o) \sum_{q_o=1}^{N_o} G(p_o, q_o) + \\ j\omega\mu_o \sum_{p_o=1}^{N_o} r_o(p_o) \sum_{q_c=1}^{N_c} G(p_o, q_c) S_c \sigma_c E_c(q_c) = U \end{aligned} \quad (9)$$

Where S_o and r_o are respectively the section and the radius of the coil loop, and σ_o is the electric conductivity. G is a function of relative coordinates between elementary loops.

7. INSPECTED PIECE EQUATION

To describe the induced electric field E_c in the massive conductive piece, we apply on it equation (8), then we can write:

In addition, since the depth penetration is relatively deep in comparison to the turn's section radius, we admit that the current density distribution in this section is uniform. Therefore, the number of elements on the sensor is equal among turns of both reels. In other words, the number of elements is N_o distributed on N_{or} on the radial direction and N_{oz} on the axial direction. The inspected metal sheet is subdivided into $N_c(N_{cr}, N_{cz})$ elements as illustrated in Figure 3.

$$\begin{aligned} 2\pi E_c(p_c) + j\omega\mu_o \sum_{\substack{q_c=1 \\ q_c \neq p_c}}^{N_c} G(p_c, q_c) S_c \sigma_c E_c(q_c) + \\ j\omega\mu_o I_o \sum_{q_o=1}^{N_o} G(p_c, q_o) = 0 \end{aligned} \quad (10)$$

Where S_c and r_c are respectively the section and the radius of the tested piece loop.

8. IMPEDANCE VARIATION

The impedance is the quotient between the voltage U and the exciting current intensity I_o . The calculation approach of the impedance variation is very important for material characterization, [9]. The impedance variation is the difference between the impedance Z in presence of the piece and the one in free space Z_0 .

$$\Delta Z = Z - Z_0 \quad (11)$$

From equation (9) and relation (11), one can finally deduce the expression of this impedance variation:

$$\Delta Z = \frac{j\omega\mu_o}{I_o} \sum_{p_o=1}^{N_o} r_o(p_o) \sum_{q_c=1}^{N_c} G(p_o, q_c) S_c \sigma_c E_c(q_c) \quad (12)$$

We have also:

$$S_c = \frac{E_c T_c}{N_c} \quad (13)$$

$$\Delta Z = \frac{j\omega\mu_o L_c}{I_o N_c} \sum_{p_o=1}^{N_o} r_o(p_o) \sum_{q_c=1}^{N_c} G(p_o, q_c) E_c(q_c) T_c \sigma_c \quad (14)$$

After having accomplished the development of the forward model, the next section will be dedicated to resolve the inverse problem which consists in measuring the coating thickness.

9. IMPEDANCE COMPONENT ACCORDING TO COATING THICKNESS

After implating the coupled circuit method on MATLAB software, we study the effect of non conductive coating thickness on sensor impedance component such as amplitude, resistance and reactance; the coated sheet metal is made of Inox304L, Aluminium, AU4G and Titanium.

From these results, we remark clearly that the resistance variation increases with the increase of coating thickness. Furthermore, greater variations are obtained for high frequencies.

Our objective in this section is not to make a deep analysis of these results because this problem is already treated in previous works, but we want to make in evidence that resistance variation ΔR changes more rapidly in comparison to the reactance variation ΔX . The next section is reserved to exploit the developed forward model for resolving the inverse problem which consists in measuring nonconductive coating thickness.

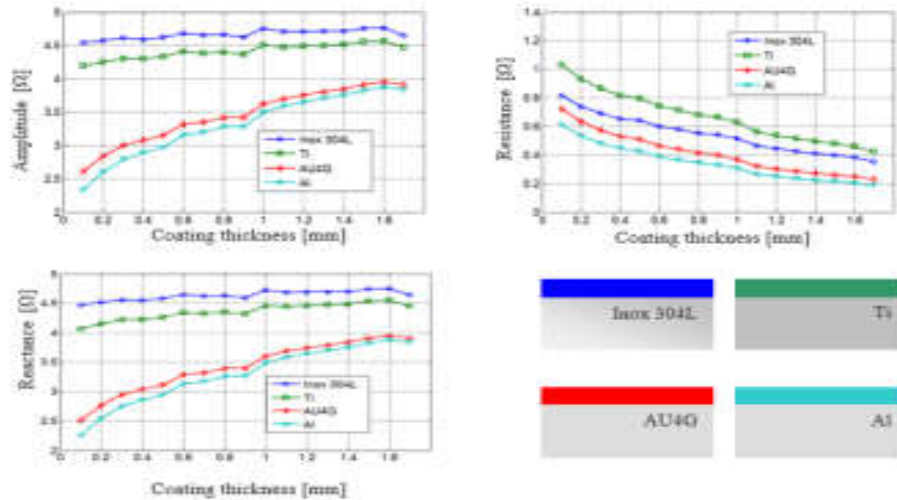

Figure 4. Impedance variation according to coating thickness for different material type. fr =10KHz

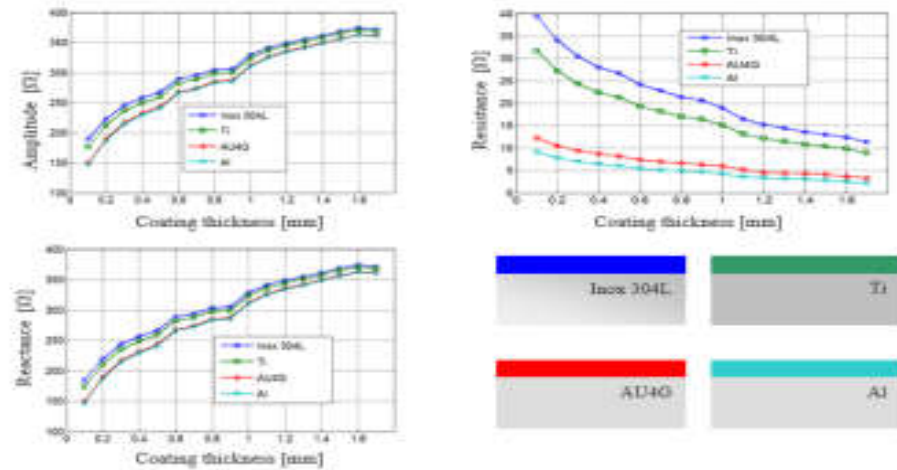

Figure 5. Impedance variation according to coating thickness for different material type. fr =10Mhz

10. DEVELOPMENT OF THE INVERSE METHOD FOR COATING THICKNESS MEASUREMENT

The inverse method that we propose in this contribution is based on the association of the forward developed model and

an algorithm researching the inverse problem solution, which is the tested piece coating thickness, from the measured impedance variation, [7]. The algorithm exploits the fact that the sensor resistance variation according to coating thickness is an increasing function ($\Delta R = f(E)$). While knowing

the physical and geometric parameters of the studied system and the starting interval limits (E_{inf} and E_{sup}), successively, by lower and upper coating thickness, the forward model determines the resistance variation corresponding to the intermediate coating thickness $\frac{E_{inf} + E_{sup}}{2}$.

If the calculated resistance ΔR is lower than ΔR_{mes} , the coating thickness E_{sup} is replaced by $\frac{E_{inf} + E_{sup}}{2}$. Otherwise, if ΔR is greater than ΔR_{mes} , the coating thickness E_{sup} is replaced by $\frac{E_{inf} + E_{sup}}{2}$. This process is repeated until the

difference between ΔR and ΔR_{mes} becomes lower than the tolerance ($|\Delta R - \Delta R_{mes}| \leq \epsilon$). These process steps are summarised in Figure 6.

This algorithm presents several advantages such as: the solution is guaranteed in advance if the sought value belongs to the starting interval. Certainly, in the industrial applications the expert knows the starting interval of coating thickness.

In the following sections, we apply the developed inverse method to determine non-conductive coating thickness of Inox304L, Aluminium, AU4G and Titanium. So, the evolution of the coating thickness, for exciting field frequency 1 kHz and 1 MHz, according to iteration number is shown on figures 7 and 8. The dielectric coating thickness is about of 0.2mm, 0.5mm and 1.2mm.

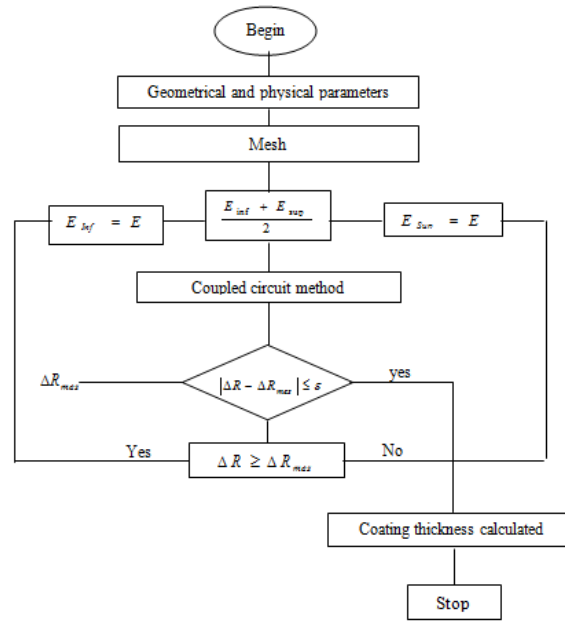

Figure 6. Proposed optimization flowchart.

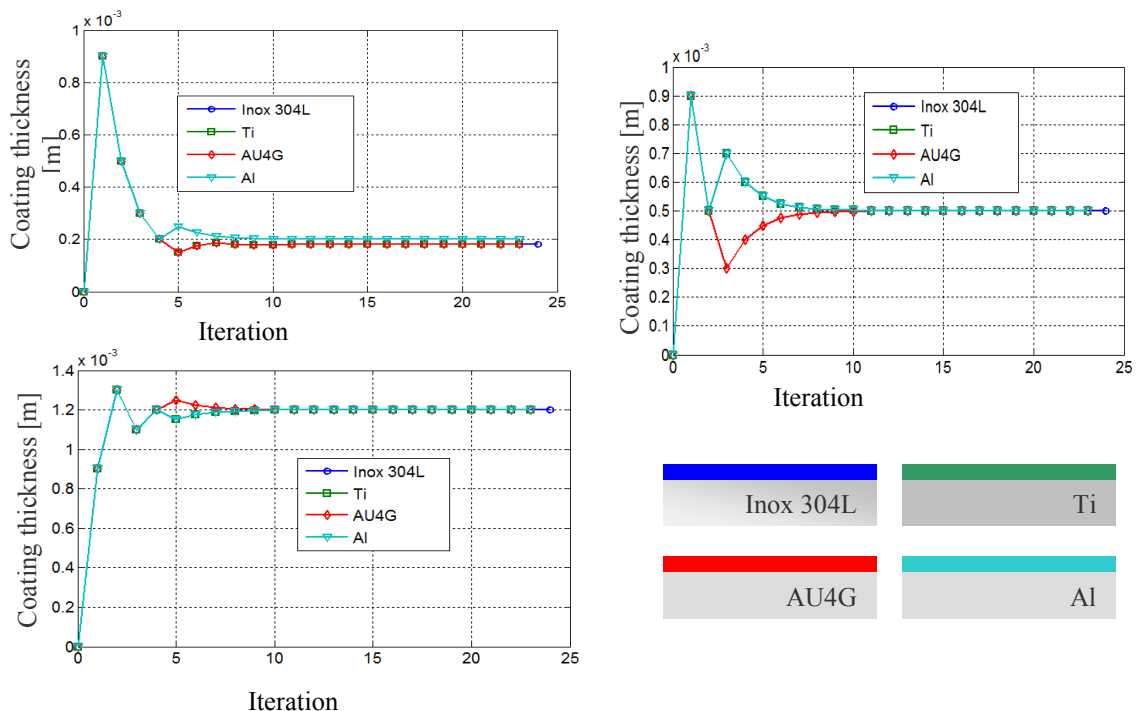

Figure 7. Coating thickness for different material type according to iteration. $f_r = 10\text{kHz}$. $f_r = 10\text{kHz}$ calculated with the proposed algorithm.

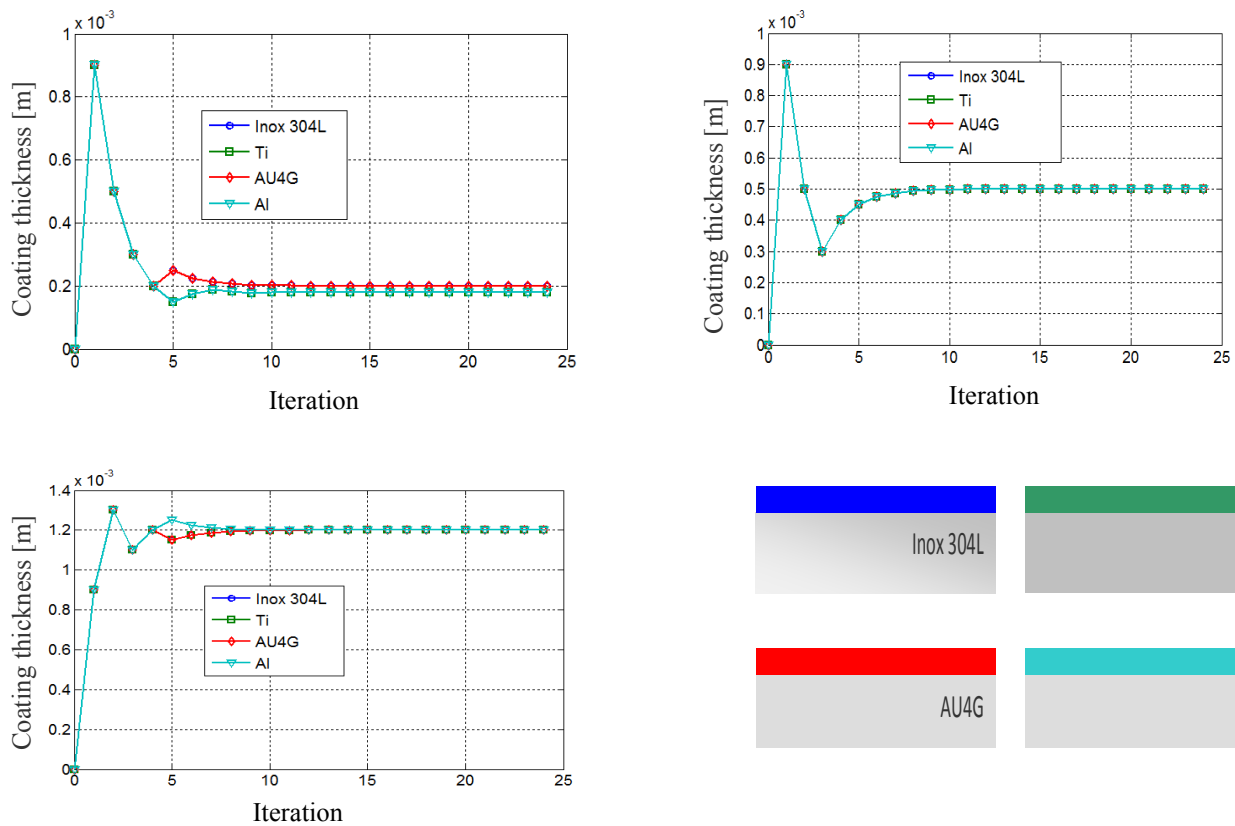

Figure 8. Coating thickness for different material type according to iteration. $f_r = 10\text{MHz}$ calculated with the proposed algorithm.

During this application, we have seen that the values obtained by the proposed method are very precise and closer to desired ones, which shows the robustness of this method. In fact, for all sheet metal type, less than 10 iteration are sufficient to determine coating thickness (0.2mm, 0.5mm and 1.2mm). Also, we know that probabilistic methods such as genetic algorithm is very expensive in computation time because of the high number of objective function evaluations at each iteration. On the other hand, to achieve an acceptable accuracy, the population size must be increased what induce a significant computation time. As a result, the proposed method is more preferred; because it is faster and its performance doesn't change when the calculation is reset, which is not the case for the other stochastic methods, [18-21].

11. CONCLUSIONS

In this paper we have exploit the deterministic method that we have recently developed for non-destructive evaluation of coating thickness aircraft construction materials, [6]. So, after implementing and running the inversion technique under Matlab environment, the simulation results has shown its rapidity and robustness while making a judicious configuration choice for initial parameters such as initial interval search and tolerance. In fact, while using this algorithm, few iteration number are sufficient for real time coating thickness measurement. As future work, we look forward to extend this inversion procedure to characterize the aeronautical metal sheet by introducing its thickness and that coatingan unknown parameters.

REFERENCES

- [1] Javier G-M, Jaime G-G, Ernesto V-S (2011). Non-destructive techniques based on eddy current testing. *Sensors Journal*, Volume 11, Issue 3, pp:2525–2565. DOI:10.3390/s110302525
- [2] Oliver Bruchwald, Martin Nicolaus, Wojciech Frackowiak, Wilfried Reimche, Kai Mohwald, Hans Jurgen Maier (2016). Material Characterization of Thin Coatings Using High Frequency Eddy Current Technology. *NDT.net Issue: 07, 19th World Conference on Non-Destructive Testing WCNDT*. <https://www.ndt.net/article/wcndt2016/papers/th3i5.pdf>
- [3] Lunin, V.P (2006). Phenomenological and algorithmic method for the solution of inverse problem of electromagnetic testing. *Russian Journal of Nondestructive Testing*, Volume 42, Issue 6, pp 353–362. DOI:10.1134/S1061830906060015
- [4] Han W., Que P. (2005). An Improved Genetic Local Search Algorithm for Defect Reconstruction from MFL Signals. *Russian Journal of Non-destructive Testing*, Volume 41, Issue 12, pp 815–821. <https://link.springer.com/article/10.1007/s11181-006-0038-z>
- [5] Dodd, C. V. and Deeds W.E (1968). Analytical Solutions to Eddy-Current Probe-Coil Probe Problems. *Journal of applied physics*, Volume 39, Issue 6, pp. 2829–2839. DOI: 10.1063/1.1656680
- [6] Amrane S., Latreche M.E.H., Feliachi M. (2010). Coupled circuits model combined with deterministic and stochastic algorithms for the inductor design.

- International-journal-of-applied-electromagnetics-and-mechanics, vol. 32, no. 4, pp. 195-206. DOI:10.3233/JAE-2010-1074
- [7] Bouchala T, Abdelhadi B, Benoudjit A (2015). New Contactless Eddy Current Non-destructive Methodology of Electric Conductivity Measurement. *Journal of Non-destructive testing and Evaluation*. Francis and Taylor. Volume 30, Issue 1, pp. 63-73. DOI: 10.1080/10589759.2014.992431
- [8] H. Zhang G. Y. Tian A. Simm M. Alamin (2013). Electromagnetic methods for corrosion under paint coating measurement. Eighth International Symposium on Precision Engineering Measurement and Instrumentation, pp. 875919-1-875919-10. DOI.org/10.1117/12.2014567
- [9] Yating Y, Pingan D, Luchuan X (2008). Coil impedance calculation of an eddy current sensor by the finite element method. *Russian Journal of Non Destructive Testing*, Volume 44, Issue 4, pp :296–302. DOI: 10.1134/S1061830908040104
- [10] Bouchala T, Abdelhadi B, Benoudjit A (2013). Novel coupled electric field method for defect characterization in eddy current non destructive testing. *Journal of Non Destructive Testing Evaluation*, Volume 32, Issue 3, pp1–11. DOI: 10.1007/s10921-013-0197-5
- [11] Maouche, B., Feliachi, M. (2006). A half analytical formulation for the impedance variation in axisymmetrical modeling of eddy current non destructive testing. *European Physical Journal - Applied Physics*, vol.33, Issue 1, pp 59–67. DOI: 10.1051/epjap:2005093
- [12] Doirat, V. (2007). Contribution à la modélisation des systèmes de contrôles non destructifs par Courants de Foucault, application à la caractérisation physique et dimensionnelle de matériaux de l'aéronautique. Doctorate Thesis Nantes University
- [13] Maouche B., Feliachi M. (1997). Analyse de l'effet des Courants induits sur l'impédance d'un système électromagnétique alimenté en tension BF ou HF. Utilisation de la méthode des circuits couplés. *Journal de Physique III*, Volume 7, Numéro 10, pp1967–1973. DOI: 10.1051/jp3:1997235
- [14] Mouhallelbi, H., Bouali, F., Feliachi, M (2010). Use of half analytical method for detection of defects in diet pulses. *Studies in Applied Electromagnetics and Mechanics*, Ebook Volume 35: Electromagnetic Nondestructive Evaluation (XIV), pp 183 – 191. DOI: 10.3233/978-1-60750-750-5-183
- [15] Zerguini S, Maouche B, Latreche M, Feliachi M (2009). A coupled fictitious electric circuit's method for impedance of a sensor with ferromagnetic core calculation. Application to eddy currents non destructive testing. *European Physical Journal Applied Physics*, Volume 48, Number 3, Number of page 6. DOI:10.1051/epjap/2009190
- [16] T. Bouchala T, Abdelhadi B, Benoudjit A (2015). Application of coupled electric field method for eddy current non-destructive inspection of multilayer structures. *Journal of Non-destructive testing and Evaluation*, Francis and Taylor, Volume 30, Issue 2. DOI.org/10.1080/10589759.2015.1018253
- [17] S. Bennoud, M. Zergoug (2014), Modeling and Simulation for 3D Eddy Current Testing in Conducting Materials. *International Journal of Mechanical, Aerospace, Industrial, Mechatronic and Manufacturing Engineering* Volume:8, Issue:4. <https://pdfs.semanticscholar.org/50ca/9656138e5b90f854765ae66d413a96075198.pdf>
- [18] A. Bouzidi, B. Maouche and M. Feliachi (2015). Pulsed Eddy Current NDE of Groove Dimensions by Inversion With Simplex Method Associated With Coupled Electric Circuits Method. *IEEE transactions on magnetics*, Volume 51, Issue 3. DOI:10.1109/TMAG.2014.2363194.
- [19] J. Yen, J. C. Liao, B. Lee, D. Randolph (1998). A hybrid approach to modelling metabolic system using a genetic algorithm and simplex method. *IEEE Transaction On System Cybernetics*, Vol. 28 Issue 2, pp. 173 - 191. DOI: 10.1109/3477.662758
- [20] A Hamel, H Mohellebi, M Feliachi (2012). Imperialist Competitive Algorithm and Particle Swarm Optimization Comparison for Eddy Current Non-destructive Evaluation. *International Journal of Computer Science*.
- [21] Mohdeb N, Mekideche MR. (2010). A fast hybrid algorithm for solving materials properties determination inverse problem. *IAENG International Journal of Computer Science*, 37(2):18–26. http://www.iaeng.org/IJCS/issues_v37/issue_2/IJCS_37_2_02.pdf