

المسيلة في : 2023/12/19

الرقم : 199/اق.إ. 2023/

شهادة إدارية

بعد الإطلاع على التقارير الإيجابية الواردة من السادة الخبراء أعضاء لجنة دراسة المطبوعة الجامعية والآتية أسماؤهم:

- | | | |
|-----------------------------|-------|--------------|
| جامعة محمد بوضياف - المسيلة | أستاذ | • روابح خالد |
| جامعة محمد بوضياف - المسيلة | أستاذ | • بوراس منير |
| جامعة فرحات عباس - سطيف 01 | أستاذ | • عياد مولود |

صادق أعضاء اللجنة العلمية على قبول المطبوعة البيداغوجية مع إمكانية إتخاذها سندا في تدريس طلبة السنة الثالثة ليسانس إتصالات، في ميدان علوم و تكنولوجيا و أن تعتمد في أي تقييم المسار العلمي للأستاذ المعني شلابي عز الدين (أستاذ محاضر قسم "أ" - جامعة محمد بوضياف - المسيلة) تحت عنوان :

Communication numérique (Digital Communication)

رئيس اللجنة العلمية

رئيس القسم

مز عاش عمار

طياخ بوضياف



PEOPLE'S DEMOCRATIC REPUBLIC OF ALGERIA
MINISTRY OF HIGHER EDUCATION AND SCIENTIFIC RESEARCH



UNIVERSITY OF MOHAMED BOUDIAF-M'SILA
FACULTY OF TECHNOLOGY
ELECTRONICS DEPARTMENT

Course handout

Module: Digital Communication

Level: 3rd year LMD, Telecommunications

Teacher: Dr. CHALABI Izzeddine

Academic year: 2023/2024

Semestre: 6
Unité d'enseignement: UEF 3.2.1
Matière: Communications numériques
VHS: 67h30 (Cours: 3h00, TD: 1h30)
Crédits: 6
Coefficient: 3

Objectifs de l'enseignement:

Les systèmes de télécommunications sont essentiellement composés de trois parties à savoir : l'Émetteur, le Canal et le Récepteur. Au niveau de l'émetteur et du récepteur des systèmes de télécommunications numériques plusieurs étapes de traitements numériques sont effectuées. L'objectif de cette matière est de donner à l'étudiant les fondements de base de ces opérations numériques.

Connaissances préalables recommandées:

Télécommunications fondamentales, Théorie du signal, Traitement du signal, Communication analogique.

Contenu de la matière:

Chapitre 1. Transmission numérique en bande de base (3 Semaines)

Éléments d'une chaîne de transmission numérique, modulation en bande de base. Codes en ligne (Conversion bits/symboles et Mise en forme), Code NRZ Bipolaire, Code NRZ unipolaire, Code RZ unipolaire, Code Biphase/Manchester, Code HDB3 (Haute Densité Bipolaire d'ordre 3), Codes en lignes M-aires (Codes NRZ M-aires), Densité spectrale de puissance des codes en ligne, Critères de choix d'un code en ligne. Notion d'enveloppe complexe.

Chapitre 2. Récepteur optimal (3 Semaines)

Structure d'un récepteur à M signaux, représentation vectorielle des signaux et du bruit, détection optimal (détecteur MAP pour maximum a posteriori et détecteur ML pour maximum likelihood), Structure du récepteur optimal (autocorrélation ou filtrage adapté sur chacune des voies puis décision).

Chapitre 3. Transmission sans interférence entre symboles (3 Semaines)

Effet du Canal sur la forme d'onde du code en ligne, Caractéristiques de l'Interférence entre symboles, Diagramme de l'œil, Condition d'absence d'interférence entre symboles, Critère de Nyquist, filtre en cosinus surélevé, Performances en termes de probabilité d'erreur d'un système M-aire avec filtrage de Nyquist, Répartition du filtrage entre l'émission et la réception.

Chapitre 4. Performances pour une transmission en bande de base (3 Semaines)

Détection d'un signal binaire et test des hypothèses, critère du maximum de vraisemblance, rapport de vraisemblance, récepteur binaire optimal à deux corrélateurs, à un seul corrélateur et à base de filtre adapté. Probabilité d'erreur pour le cas d'un bruit blanc gaussien avec filtre passe bas et filtre adapté.

Chapitre 5. Modulations numériques à bande étroite (3 Semaines)

Principe, Modulation à déplacement d'amplitude (ASK), Modulation OOK, Modulations M-ASK symétriques, Réalisation physique et performances, Modulation à déplacement de phase (PSK), Constellations, Modulations M-PSK, Réalisation physique et performances, Modulation à deux porteuses en quadratique (QAM), Réalisation physique et performances, Modulation à déplacement de fréquence (FSK), Modulation MSK, Réalisation physique et performances d'une FSK binaire

Mode d'évaluation:

Contrôle continu: 40% ; Examen: 60%.

Contents

Chapter 1: Baseband Digital Transmission

1.1	Elements of Digital Transmission Chain	5
1.2	Line Codes	5
1.2.1	Bipolar NRZ	6
1.2.2	Unipolar NRZ	6
1.2.3	Unipolar RZ	7
1.2.4	Bipolar RZ	7
1.2.5	Manchester	8
1.2.6	Differential Manchester	8
1.2.7	AMI	9
1.2.8	Miller	9
1.2.9	NRZI	10
1.2.10.	M-ary NRZ	10
1.3	Power Spectral Density	11
1.4	Criteria for Choosing a Line Code	13
1.5	Exercises	14

Chapter 2: Optimum Receivers

2.1	Waveform and Vector Channel Models	17
2.2	Vector View of Signals and Noise	17
2.2.1	Waveform Energy	18
2.2.2	Representation of the AWGN Noise	18
2.3	Matched Filter	19
2.4	Optimal Detector	21
2.4.1	Maximum <i>A Posteriori</i> (MAP) Decision Rule	21
2.4.2	Maximum Likelihood (ML) Decision Rule	21
2.5	Exercises	22

Chapter 3: Transmission Without Intersymbol Interference

3.1	Introduction	25
3.2	Intersymbol Interference	25
3.3	Nyquist Criterion	27
3.4	Eye Diagram	30
3.5	Exercises	32

Chapter 4: Performance of Baseband Transmission		
4.1	Binary Detection in AWGN Channel	34
4.2	Maximum Likelihood (ML) Detector	35
4.3	Error Probability	36
4.5	Exercises	40
Chapter 5: Narrowband Digital Modulations		
5.1	Introduction	44
5.2	Amplitude Shift Keying (ASK)	44
5.2.1	B-ASK (Binary ASK)	45
5.2.2	Constellation Diagram	45
5.2.3	Detection of B-ASK Signals	47
5.3	Frequency Shift Keying (FSK)	48
5.3.1	Noncoherent Detection of B-FSK Signals	48
5.4	Phase Shift Keying (PSK)	49
5.5	Quadrature Amplitude Modulation (QAM)	50
5.6	IQ Modulator/Detector	51
5.6.1	IQ Modulator	51
5.6.2	IQ Detector	52
5.7	Exercises	53
	References	56

Chapter 1

Baseband Digital Transmission

1.1. Elements of Digital Transmission Chain

Transmission is said to be baseband when the signal does not undergo frequency transposition. In this case the signal often has a rectangular appearance, because the modulation function used is rectangular. Baseband transmission consists of directly transmitting digital signals in electrical form on electrical conductors, over limited distances (of the order of 30 Km). The elements of a digital transmission chain are represented in the block diagram in Figure.1.1.

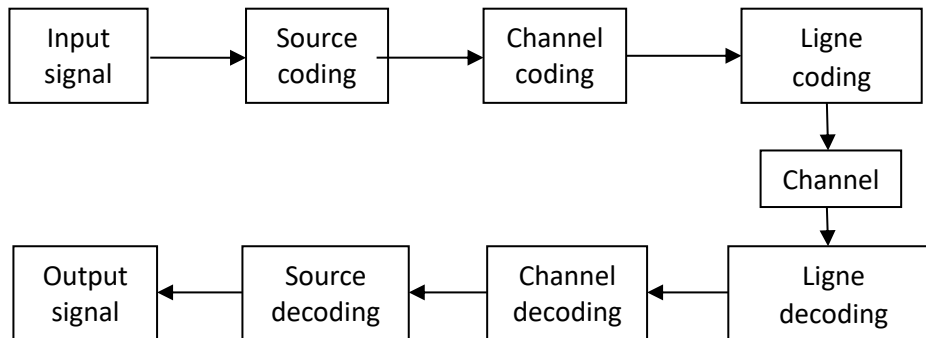

Figure.1.1. Elements of a digital transmission chain

-*Source coding*: the role of source coding is the compression of information, reducing the quantity of binary data transmitted (symbols coded by words of variable lengths, for example the Huffman algorithm).

-*Channel coding*: the goal is the detection and/or correction of errors caused in reception by the channel noise (improve the Bit Error Rate (BER)).

-*Line coding*: this is the formatting of data in the form of pulses.

-*Channel*: is a medium allowing the transmission of a certain quantity of information, from a source to a receiver.

1.2. Line codes

A line code is the code used for data transmission of a digital signal over a transmission channel. This process of coding is chosen so as to avoid for example the overlap and distortion of signal such as intersymbol interference.

1.2.1. Bipolar NRZ

Bipolar NRZ (Non-Return to Zero) code is based on the association of an amplitude $+A$ with the bit $d_k = 1$ and an amplitude $-A$ with the bit $d_k = 0$. This code can be written into symbols a_k multiplying a transmission filter $g(t)$, the transmit signal $x(t)$ is written in the following form:

$$x(t) = \sum_k a_k g(t - kT) \quad (1.1)$$

where $g(t) = A \cdot \text{rect}\left(\frac{t}{T}\right)$, A is the amplitude and $\text{rect}(\cdot)$ is rectangular pulse (Figure.1.2).

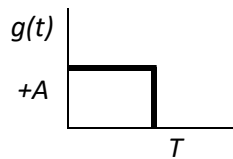

Figure.1.2. Rectangular pulse

The symbols a_k associated with the bits are:

$$\begin{cases} a_k = 1 & \text{if } d_k = 1 \\ a_k = -1 & \text{if } d_k = 0 \end{cases}$$

Example:

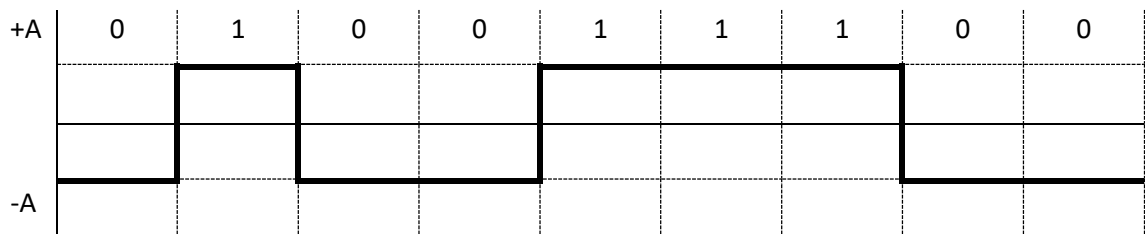

Figure.1.3. Bipolar NRZ

1.2.2. Unipolar NRZ

Unipolar NRZ code is similar to bipolar NRZ except that the bit $d_k = 0$ is associate with the symbol $a_k = 0$.

Example:

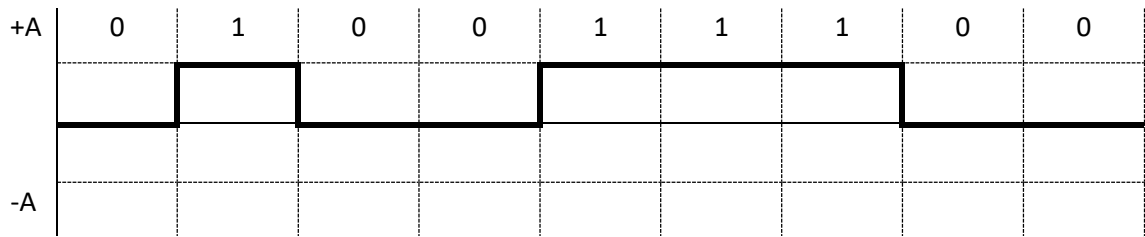

Figure.1.4. Unipolar NRZ

The main limitations of NRZ signals are the presence of the direct component DC and the lack of ability to synchronize. To explain the latter issue, consider that when a long string of 1's is received for NRZ, the output is a constant voltage, and there is no transition that can help align the received clock to the middle of the symbol. As such, a drift between transmitter and receiver cannot be corrected based on the signal alone.

1.2.3. Unipolar RZ

Unipolar RZ associates with the bit $d_k = 1$ an amplitude $+A$ during $[0, T/2]$ and an amplitude 0 during $[T/2, T]$, for the bit $d_k = 0$ it associates an amplitude 0.

In this case $g(t)$ is given as:

$$g(t) = \begin{cases} +A & \text{if } t \in [0, T/2] \\ 0 & \text{if } t \in [T/2, T] \end{cases} \quad (1.2)$$

Example:

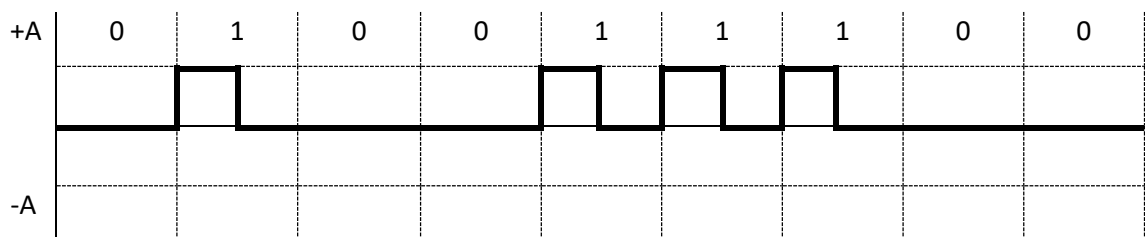

Figure.1.5. Unipolar RZ

1.2.4. Bipolar RZ

Bipolar RZ code associates with the bit $d_k = 1$ an amplitude $+A$ during $[0, T/2]$ and an amplitude 0 during $[T/2, T]$, for the bit $d_k = 0$ it associates an amplitude $-A$ during $[0, T/2]$ and an amplitude 0 during $[T/2, T]$.

Example:

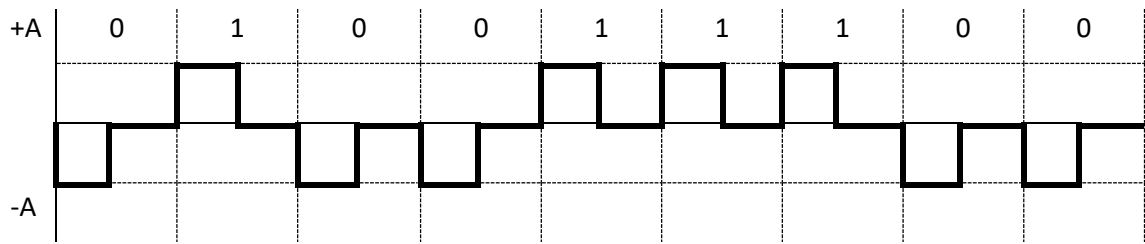

Figure.1.6. Bipolar RZ

1.2.5. Manchester

This code associates with the bit $d_k = 1$ an amplitude $+A$ during $[0, T/2]$ and an amplitude $-A$ during $[T/2, T]$, for the bit $d_k = 0$ it associates an amplitude $-A$ during $[0, T/2]$ and an amplitude $+A$ during $[T/2, T]$.

Example:

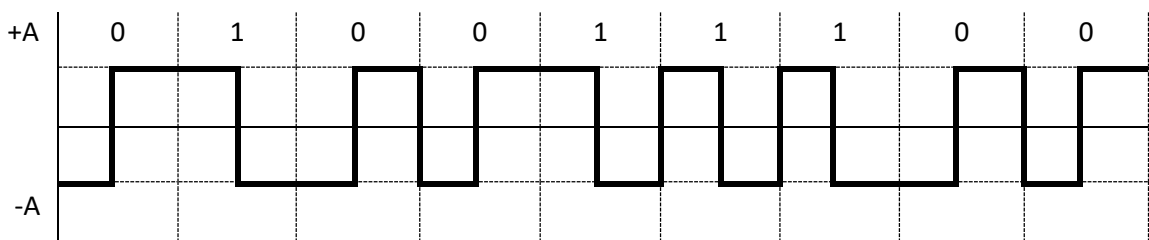

Figure.1.7. Manchester

Manchester codes are expected to overcome the disadvantages of NRZ. The Manchester schemes require at least one transition per bit time. The Manchester code has several advantages:

- Synchronization: Since there is a predictable transition during each bit time, the receiver can synchronize on the transition. For Manchester, there is always a transition in the middle of each bit interval.
- Manchester code has no DC component.

1.2.6. Differential Manchester

In this code, for the bit $d_k = 0$ the previous state is repeated and for the bit $d_k = 1$ the previous state is reversed.

Example:

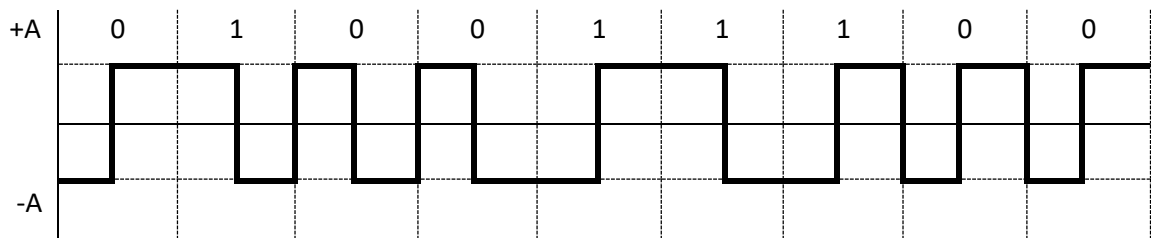

Figure.1.8. Differential Manchester

The advantage of the differential Manchester code compared to the Manchester code is there is no polarity respected.

1.2.7. AMI

AMI (Alternate Mark Inversion) code associates with $d_k = 1$ an amplitude $+A$ and an amplitude $-A$. The bit $d_k = 0$ is associated with an amplitude 0. A change of sign is imposed between two successive amplitudes representing a bit equal to 1.

Example:

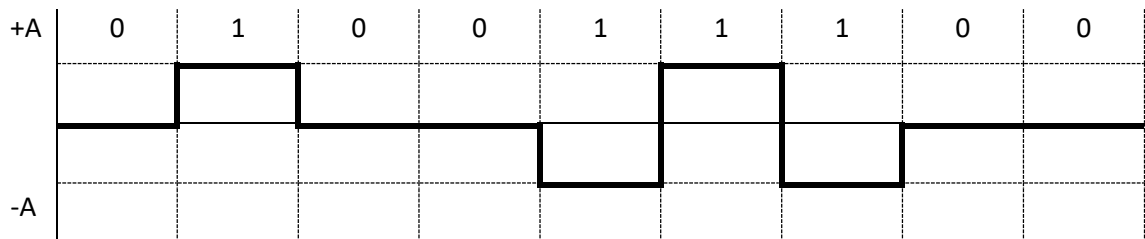
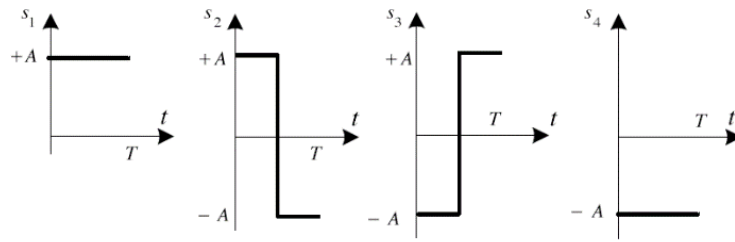

Figure.1.9. AMI

1.2.8. Miller

This code associates with each bit $d_k = 1$ either an amplitude $+A$ during $T/2$, then an amplitude $-A$ during $T/2$, or an amplitude $-A$ during $T/2$ then an amplitude $+A$ during $T/2$. To each bit $d_k = 1$, it associates an amplitude $-A$ or an amplitude $+A$ during the entire period of the symbol. The polarity of the signal associated with a bit $d_k = 1$ is chosen in order to obtain continuity with the previous pulse. The polarity of a signal associated with a bit $d_k = 0$ is chosen in order to obtain continuity with the previous pulse if it corresponded to a bit $d_k = 1$.



Example:

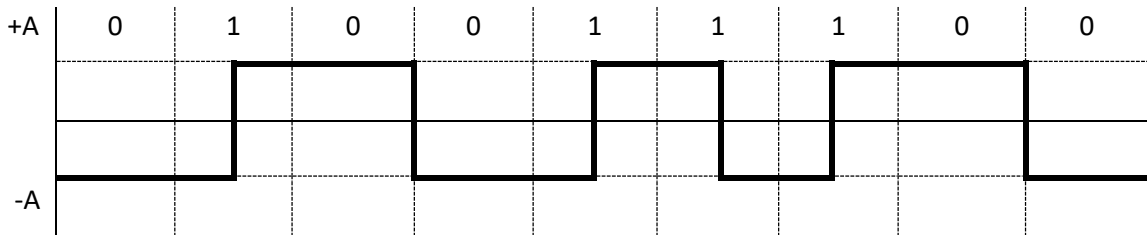

Figure.1.10. Miller

1.2.9. NRZI

For NRZI (NRZ Inverted) code, the value of the transmitted bit is not indicated by the amplitude, but by the transitions; if there is a change of state ($+A$ to $-A$ or $-A$ to $+A$), then the transmitted bit is equal to 1; whereas if there is no change of state, the transmitted bit is equal to 0.

Example:

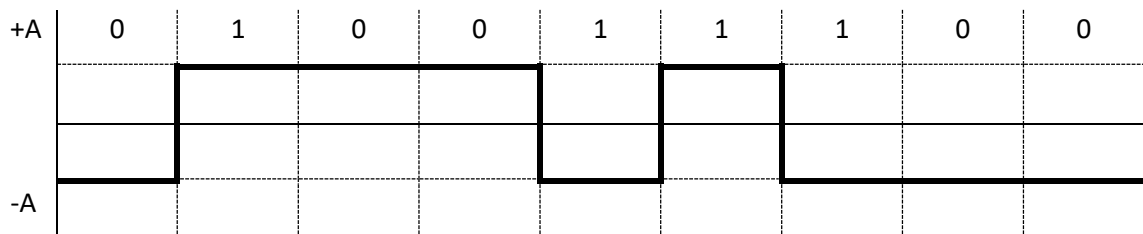

Figure.1.11. NRZI

1.2.10. M-ary NRZ

The M-ary NRZ code is an example of line code that does not modulate bits, but symbols composed of a several bits. The symbols a_k may take more than two values. For M-ary NRZ codes with M equal to a power of 2, bits are grouped by blocks of $\log_2(M)$ bits. Each block is then encoded on a symbol a_k . The Figure.1. shows example of M-ary NRZ code with $M = 4$.

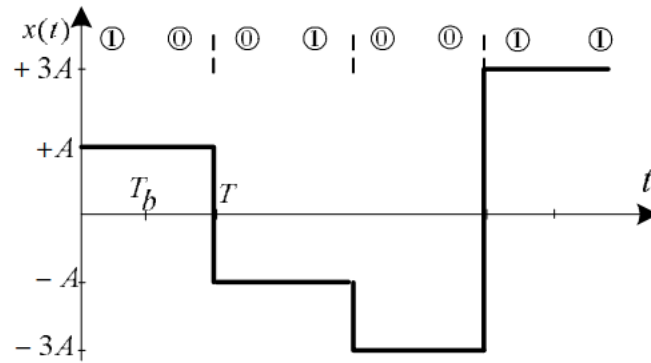

Figure.1.12. M-ary NRZ with $M = 4$

1.3. Power Spectral Density

Each online code is characterized by its own power spectral density (PSD), it can be obtained using Bennett formula. The baseband signal $x(t)$ can be written as:

$$x(t) = \sum_k a_k g(t - kT) \quad (1.4)$$

where a_k are the transmit symbols and $g(t)$ is the transmission filter.

$$\gamma_{XX}(f) = \frac{1}{T} |G(f)|^2 \gamma_{AA}(f) \quad (1.5)$$

where $G(f)$ is the spectrum of $g(t)$, $\gamma_{AA}(f) = \sum_n R_{aa}(n) e^{-j2\pi f n T}$ and $R_{aa}(n)$ is the autocorrelation.

Some PSDs of the codes seen previously are given below.

-NRZ

$$\gamma_{XX}(f) = A^2 T \sin^2(\pi f T) \quad (1.6)$$

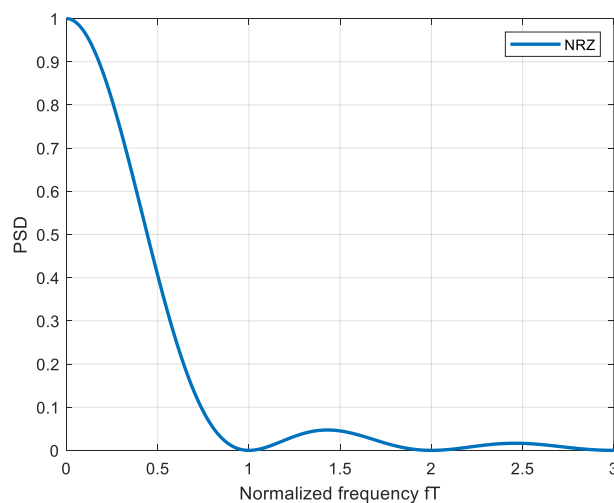

Figure.1.13. PSD of NRZ

-Unipolar RZ

$$\gamma_{XX}(f) = \frac{A^2 T}{16} \sin^2 c^2 \left(\pi f \frac{T}{2} \right) + \frac{A^2}{16} \sum_i \delta \left(f - \frac{i}{T} \right) \sin^2 c^2 \left(\pi f \frac{T}{2} \right) \quad (1.7)$$

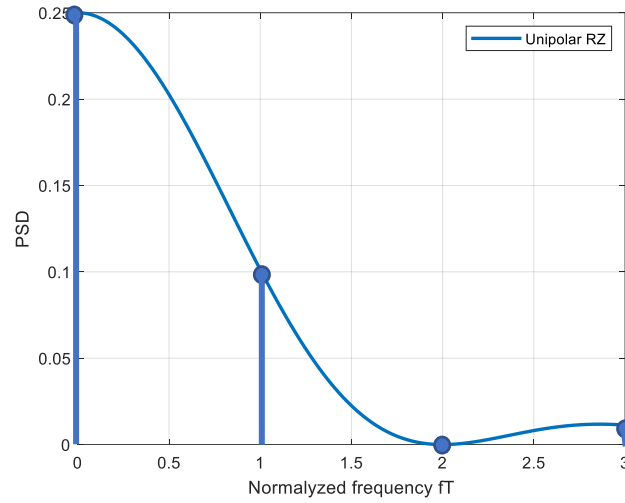

Figure.1.14. PSD of unipolar RZ

- Bipolar RZ

$$\gamma_{XX}(f) = \frac{A^2 T}{4} \sin^2 c^2 \left(\pi f \frac{T}{2} \right) \quad (1.8)$$

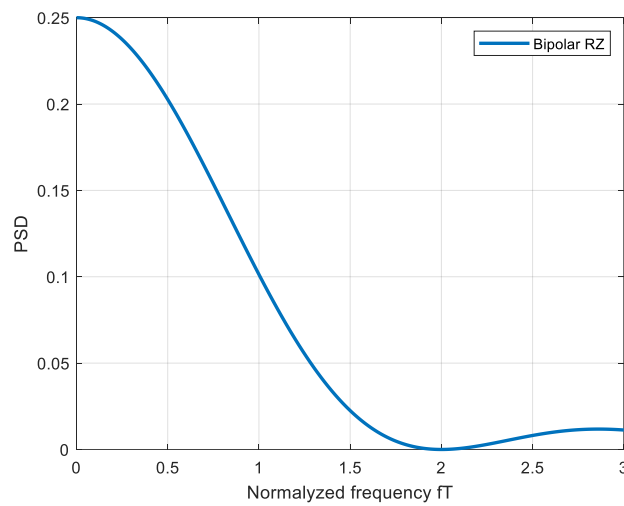

Figure.1.15. PSD of bipolar RZ

- Manchester

$$\gamma_{XX}(f) = A^2 T \sin^2 c^2 \left(\pi f \frac{T}{2} \right) \sin^2 \left(\pi f \frac{T}{2} \right) \quad (1.9)$$

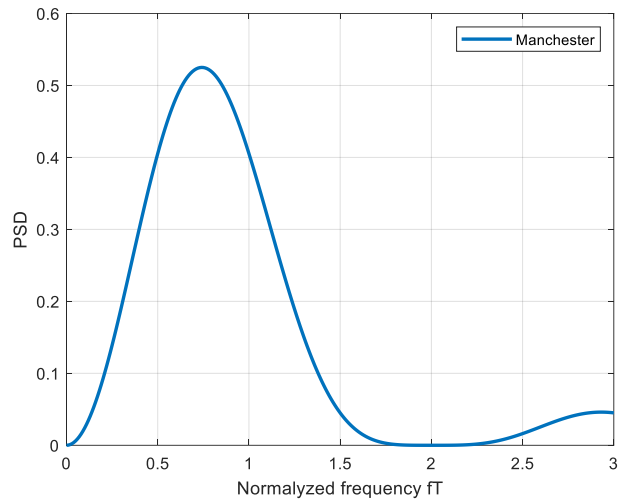

Figure.1.16. PSD of Manchester

-M-ary NRZ

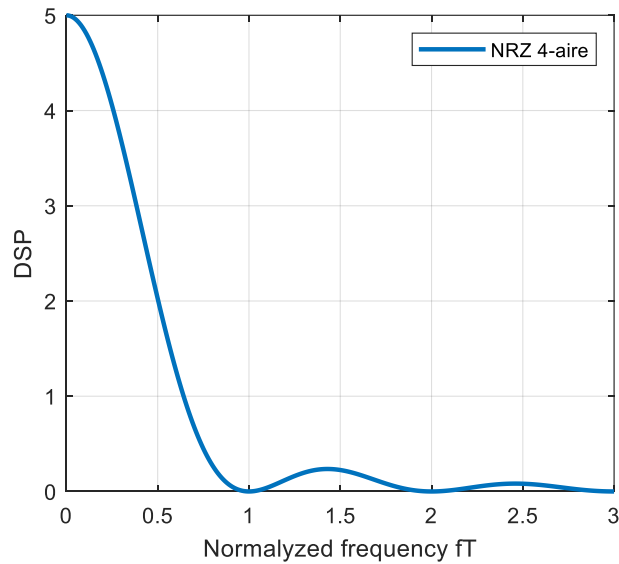

Figure.1.17. PSD of M-ary NRZ with $M = 4$

1.4. Criteria for Choosing a Line Code

The choice of a line code is made according to the power spectral density of the code and the noise resistance. The criteria for choosing a line code are:

- Noise sensitivity.
- Bandwidth.
- Synchronization (Clock recovery at the receiver).
- DC component.

where $R_a(n)$ is the autocorrelation.

Chapter 2

Optimum Receivers

2.1 Structure of M -signals Receiver

In this chapter, the channel is considered additive white Gaussian noise (AWGN) channel. This channel is mathematically described as:

$$r(t) = s_i(t) + n(t)$$

where $r(t)$ is the received signal, $s_i(t)$ is the transmitted signal which is one of M possible signals and $n(t)$ is the white Gaussian noise.

The main objective of the optimum receiver is the finding of the transmitted signal by the minimizing the error rate. The Figure 2.1 show the structure of the optimal receiver.

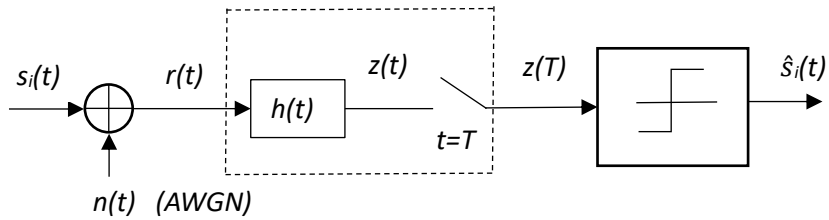

Figure.2.1. Receiver structure

The detection is performed by two steps, demodulation and the detection. The first step consists to maximizes the signal to noise ratio (SNR) using the reception filter $h(t)$ and then the signal will be sampled at $t = T$. After that, the detection step is performed using threshold comparison to decide which signal is sent. The reception filter can be a correlator filter or matched filter.

2.2. Vector View of Signals and Noise

We define an N -dimensional orthogonal space by a set of orthogonal bases $\psi_j(t)$. The basis functions must satisfy the condition:

$$\int_{-\infty}^{+\infty} \psi_j(t)\psi_k(t) = \begin{cases} 1 & \text{for } j = k \\ 0 & \text{otherwise} \end{cases} \quad (2.1)$$

Any arbitrary signal $s_i(t)$ can be expressed as linear combination of N orthogonal bases $\psi_j(t)$ as:

$$s_1(t) = a_{11}\psi_1(t) + a_{12}\psi_2(t) + \dots + a_{1N}\psi_N(t)$$

$$s_2(t) = a_{21}\psi_1(t) + a_{22}\psi_2(t) + \dots + a_{2N}\psi_N(t)$$

.

.

.

$$s_M(t) = a_{M1}\psi_1(t) + a_{M2}\psi_2(t) + \dots + a_{MN}\psi_N(t)$$

The general form can be expressed as:

$$s_i(t) = \sum_{j=1}^N a_{ij} \psi_j(t) \quad \begin{array}{l} i = 1, \dots, M \\ N \leq M \end{array} \quad (2.2)$$

where

$$a_{ij} = \int_0^T s_i(t) \psi_j(t) dt \quad (2.3)$$

2.2.1. Waveform Energy

The energy of the waveform $s_i(t)$ over symbol time T can be expressed as:

$$\begin{aligned} E_i &= \int_0^T s_i^2(t) dt \quad (2.4) \\ &= \int_0^T \left[\sum_{j=1}^N a_{ij} \psi_j(t) \right]^2 dt \\ &= \int_0^T \sum_{j=1}^N a_{ij} \psi_j(t) \cdot \sum_{j=1}^N a_{ij} \psi_j(t) dt \\ &= \int_0^T \sum_{j=1}^N a_{ij} a_{ij} \psi_j(t) \psi_j(t) dt \\ &= \sum_{j=1}^N a_{ij} a_{ij} \int_0^T \psi_j(t) \psi_j(t) dt \\ E_i &= \sum_{j=1}^N a_{ij}^2 \quad (2.5) \end{aligned}$$

2.2.2. Representation of the AWGN Noise

The AWGN noise can be expressed as a combination of orthogonal bases in the same way as signals:

$$n(t) = \sum_{j=1}^N n_j \psi_j(t) \quad (2.6)$$

where

$$n_j = \int_0^T n(t) \psi_j(t) dt \quad (2.7)$$

The power spectral density (PSD) of the AWGN noise is $N_0/2$ for all frequencies from $-\infty$ to $+\infty$, the variance of the AWGN noise (the noise is zero mean) is:

$$\sigma_0^2 = \text{Var}[n(t)] = \int_{-\infty}^{+\infty} \frac{N_0}{2} df = \infty \quad (2.7)$$

The variance of AWGN at the output of the correlator for finite symbol time T is given as:

$$\sigma_0^2 = \text{Var}[n(t)] = E \left\{ \left[\int_0^T n(t) \psi_j(t) dt \right]^2 \right\} = \frac{N_0}{2} \quad (2.7)$$

2.3. Matched Filter

The matched filter provides the maximum signal to noise ratio. At $t = T$, the sampler output $z(T)$ contain a_i signal component and n_o noise component. so, the SNR is:

$$\left(\frac{S}{N} \right)_T = \frac{a_i^2}{\sigma_0^2} \quad (2.9)$$

The goal is to find the transfer function $H_0(f)$ that maximizes the SNR. The signal $a_i(t)$ at the output of the filter can be express as:

$$z(t) = \int_{-\infty}^{+\infty} H(f) S(f) e^{j2\pi f t} df \quad (2.10)$$

The power of the noise at the output of the filter is:

$$\sigma_0^2 = \frac{N_0}{2} \int_{-\infty}^{+\infty} |H(f)|^2 df \quad (2.11)$$

where $N_0/2$ is the PSD of the noise.

The SNR will be expressed as:

$$\left(\frac{S}{N} \right)_T = \frac{\left| \int_{-\infty}^{+\infty} H(f) S(f) e^{j2\pi f T} df \right|^2}{\frac{N_0}{2} \int_{-\infty}^{+\infty} |H(f)|^2 df} \quad (2.12)$$

using the Schwarz's inequality:

$$\left| \int_{-\infty}^{+\infty} f_1(x) f_2(x) dx \right|^2 \leq \int_{-\infty}^{+\infty} |f_1(x)|^2 dx \int_{-\infty}^{+\infty} |f_2(x)|^2 dx \quad (2.12)$$

The equality is holds if $f_1(x) = k f_2^*(x)$, where k is constant and $*$ is the complex conjugate. If we put $f_1(x) = H(f)$ and $f_2(x) = S(f) e^{j2\pi f T}$, we obtain:

$$\begin{aligned} & \left| \int_{-\infty}^{+\infty} H(f) S(f) e^{j2\pi f T} df \right|^2 \\ & \leq \int_{-\infty}^{+\infty} |H(f)|^2 df \int_{-\infty}^{+\infty} |S(f) e^{j2\pi f T}|^2 df \end{aligned} \quad (2.13)$$

and the SNR became:

$$\left(\frac{S}{N} \right)_T \leq \frac{2}{N_0} \int_{-\infty}^{+\infty} |S(f)|^2 df \quad (2.14)$$

so,

$$\max \left(\frac{S}{N} \right)_T \leq \frac{2E}{N_0} \quad (2.15)$$

where $E = \int_{-\infty}^{+\infty} |S(f)|^2 df$ is the energy of the input signal.

The Schwarz's equality is holds if $f_1(x) = kf_2^*(x)$, so:

$$H(f) = H_0(f) = kS^*(f)e^{-j2\pi fT} \quad (2.16)$$

or

$$h(t) = FT^{-1}\{kS^*(f)e^{-j2\pi fT}\} \quad (2.17)$$

The final expression of the matched filter is:

$$h(t) = \begin{cases} ks(T-t) & 0 \leq t \leq T \\ 0 & \text{otherwise} \end{cases} \quad (2.18)$$

The impulse response of a filter that maximizes the SNR is the mirror image of the message signal $s(t)$ delayed by a symbol time duration T as shown in figure 2.2.

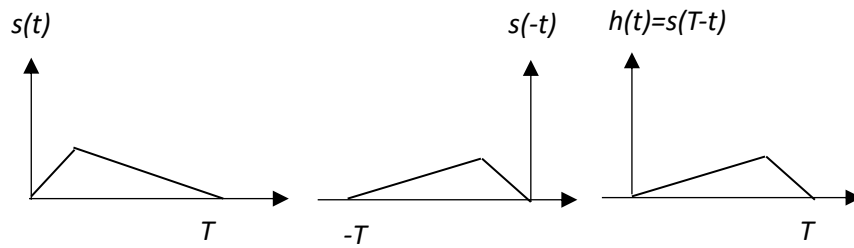

Figure 2.3. Matched filter transfer function

The structure of the receiver with matched filter is represented in Figure.2.4.

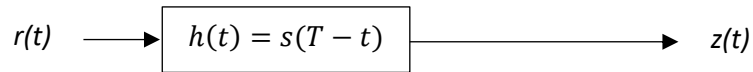

Figure.2.4. Structure of receiver with matched filter

The signal at the output of the matched filter is:

$$z(t) = r(t) * h(t) \quad (2.19)$$

$$z(t) = \int_0^t r(\tau)h(t-\tau)d\tau$$

$$z(t) = \int_0^t r(\tau)s(T-(t-\tau))d\tau$$

$$z(t) = \int_0^t r(\tau)s(T-t+\tau)d\tau \quad (2.20)$$

at $t = T$

$$z(T) = \int_0^T r(\tau)s(T-T+\tau)d\tau$$

$$z(T) = \int_0^T r(\tau)s(\tau)d\tau \quad (2.21)$$

We observe that the adapted filter provides the same result as the correlator filter.

The Structure of the receiver with correlator filter is shown in Figure.2.5.

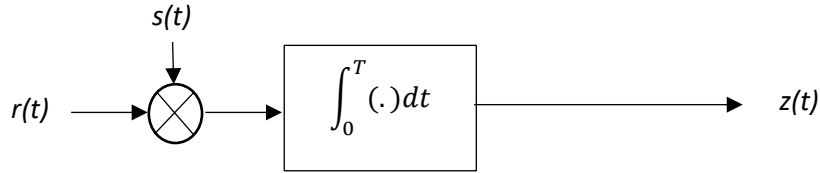

Figure.2.5. Structure of receiver with correlator filter

2.4. Optimal Detector

The objective of the optimal detector is to determine the symbol most likely transmitted. Assuming that the emitted signal s_i with conditional probability $p(s_i/z)$, where z is the received signal after the matched filter.

2.4.1. Maximum A Posteriori (MAP) Decision Rule

The MAP detector is based on finding over all possible transmitted signals s_i the signal \hat{s} with the maximum conditional probability as:

$$\hat{s} = \underbrace{\operatorname{argmax}}_{s_i} \{p(s_i/z)\} \quad (2.22)$$

using Bayes theorem:

$$p(s_i/z) = \frac{p(z/s_i)p(s_i)}{p(z)} \quad (2.23)$$

where $p(z/s_i)$ is the conditional probability density function (pdf) of the observed vector z given s_i , $p(s_i)$ is *a priori* probability of the transmitted symbols and $p(z)$ is the probability of the received signal.

The $p(z)$ probability is common for all signals, so, the MAP detector rule becomes:

$$\hat{s} = \underbrace{\operatorname{argmax}}_{s_i} \{p(z/s_i)p(s_i)\} \quad (2.24)$$

2.4.2. Maximum Likelihood (ML) Decision Rule

MAP rule requires the knowledge of both $p(z/s_i)$ and $p(s_i)$, in some applications $p(s_i)$ is unknown at the receiver. If all s_i symbols are equally probable: $p(s_i) = \frac{1}{M}, i = 1, \dots, M$. The ML decision rule is given as:

$$\hat{s} = \underset{s_i}{\operatorname{argmax}} \{p(z/s_i)\} \quad (2.25)$$

2.5. Exercises

Exercise 1:

1-The figure (a) below shows a set of three waveforms $s_1(t)$, $s_2(t)$ and $s_3(t)$. Demonstrate that these waveforms do not form an orthogonal set.

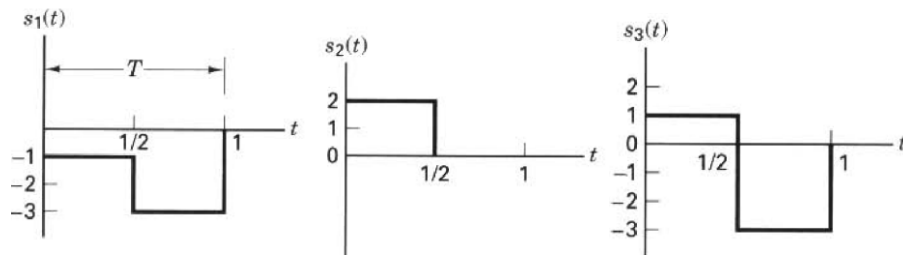

Figure (a)

2-The Figure (b) shows a set of two waveforms $\psi_1(t)$ and $\psi_2(t)$. Verify that these waveforms form an orthogonal set.

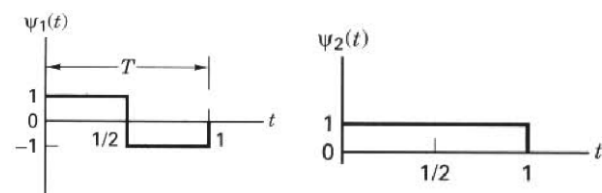

Figure (b)

3- Show that the three waveforms $s_1(t)$, $s_2(t)$ and $s_3(t)$ can be expressed as a linear combination of the orthogonal set in part 2.

Exercise 2:

A matched filter has the frequency response:

$$H(f) = \frac{1 - e^{-j2\pi f}}{j2\pi f}$$

1. Determine the impulse response $h(t)$ corresponding to $H(f)$.
2. Determine the signal waveform to which the filter characteristic is matched.

Exercise 3:

Consider the signal:

$$s(t) = \begin{cases} (A/T)t \cos 2\pi f_c t & 0 \leq t \leq T \\ 0 & \text{otherwise} \end{cases}$$

1. Determine the impulse response of the matched filter for the signal.
2. Determine the output of the matched filter at $t = T$.
3. Suppose the signal $s(t)$ is passed through a correlator that correlates the input $s(t)$ with $s(t)$. Determine the value of the correlator output at $t = T$. Compare your result with that in part 2.

Chapter 3

Transmission Without InterSymbol Interference

3.1. Introduction

In many applications such as mobile communications and satellite communications, the bandwidth is limited and the objective is to transmit with the highest possible data rate in the given bandwidth. The transmit filter's frequency response defines the spectral characteristics of the transmission. Since the signal has a limited bandwidth, the transmit filter cannot be a rectangular function of duration T . Indeed, the frequency response of such a transmit filter is $G(f) = \frac{\sin(\pi f T)}{\pi f T}$, whose spectral band is infinite. As a result, it is necessary to determine finite-band transmit filters that allow us to remove intersymbol interference (ISI) at the receiver.

Intersymbol interference occurs when a pulse spreads out in a way that it interferes with adjacent pulse at the sample instant as shown in Figure.3.1.

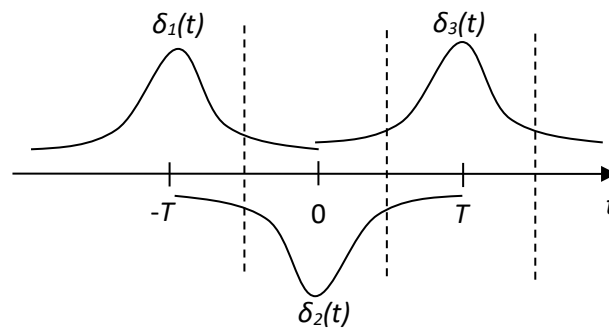

Figure.3.1. Intersymbol Interference

3.2. Intersymbol Interference

We assume that the signal transmitted on band-limited channel as shown in Figure.3.2, where a_k is a set of real symbols, and $h_t(t)$ is the transmit filter. This signal is then modified by the transmission channel, which is in general modelled by a linear filter with impulse response $h_c(t)$. Also, the channel adds white Gaussian noise $b(t)$.

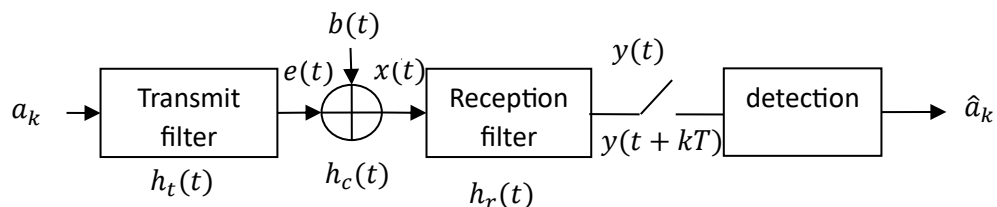

Figure.3.2. Band-Limited Channel

The signal $e(t)$ in the output of the transmit filter is:

$$e(t) = \sum_{k=-\infty}^{+\infty} a_k h_t(t - kT) \quad (3.1)$$

The received signal $x(t)$ is:

$$\begin{aligned} x(t) &= e(t) * h_c(t) + b(t) \\ &= \int_{-\infty}^{+\infty} h_c(\tau) e(t - \tau) d\tau + b(t) \end{aligned} \quad (3.2)$$

The signal $y(t)$ after the reception filter $h_r(t)$ is then written as:

$$y(t) = x(t) * h_c(t) * h_r(t) + n(t) \quad (3.4)$$

where $n(t) = b(t) * h_r(t)$

$$y(t) = \sum_{k=-\infty}^{+\infty} a_k h_t(t - kT) * h_c(t) * h_r(t) + n(t) \quad (3.5)$$

$$y(t) = \sum_{k=-\infty}^{+\infty} a_k p(t - kT) + n(t) \quad (3.6)$$

where $p(t) = h_t(t) * h_c(t) * h_r(t)$ the equivalent filter of the impulse response of the convolution of the transmit filter, transmission channel and receive filter. Its frequency response is:

$$P(f) = H_t(f) \cdot H_c(f) \cdot H_r(f) \quad (3.7)$$

$y(t)$ is then sampled at symbol period kT :

$$\begin{aligned} y(kT) &= \sum_{i=-\infty}^{+\infty} a_i p(kT - iT) + n(kT) \\ &= a_k h(0) + \sum_{i \neq k}^{+\infty} a_i p(kT - iT) + n(kT) \end{aligned} \quad (3.8)$$

This expression contains three elements:

- The first element is proportional to the k^{th} transmitted symbol.
- The second element is the contribution of all other transmitted symbols on sample $y(kT)$ and represent the intersymbol interference.

– The third element is the noise contribution.

Both intersymbol interference and noise decrease the performances of the transmission system, since they prevent the receiver from correctly estimating the symbol transmitted at time kT . As a result, both transmit and receive filters must be chosen so as to minimize them.

3.3. Nyquist Criterion

To ensure that no intersymbol interference, the complete filter $p(t)$ must verify the following condition:

$$p(KT) = \begin{cases} 1 & \text{if } k = 0 \\ 0 & \text{if } k \neq 0 \end{cases} \quad (3.9)$$

In the frequency domain, Nyquist criterion becomes:

$$\sum_{i=-\infty}^{+\infty} p\left(f + \frac{i}{T}\right) = T \quad (3.10)$$

The channel transmission's bandwidth B is defined by $H_c(f) = 0$ when $f > B$. The Nyquist criterion depends on the bandwidth B and the symbol period T . There are three cases as shown in Figure.3.3.

– if $B < \frac{1}{2T}$, then there is no filter $p(f)$ that verifies the Nyquist criterion;

– if $B = \frac{1}{2T}$, a unique solution exists: $p(f)$ must be the frequency response of a perfect lowpass filter with cutoff frequency B :

$$p(f) = \begin{cases} T & \text{if } |f| < B = \frac{1}{2T} \\ 0 & \text{elsewhere} \end{cases} \quad (3.11)$$

Its impulse response is:

$$p(t) = \frac{\sin(\pi t/T)}{\pi t/T} \quad (3.12)$$

This perfect lowpass filter with cutoff frequency $f = \frac{1}{2T}$ cannot physically be implemented. In addition, the impulse response of this filter has a low decrease and is of infinite duration.

– if $B > \frac{1}{2T}$, then several filters $p(f)$ verify the Nyquist criterion. Among these filters, we find the raised cosine filters.

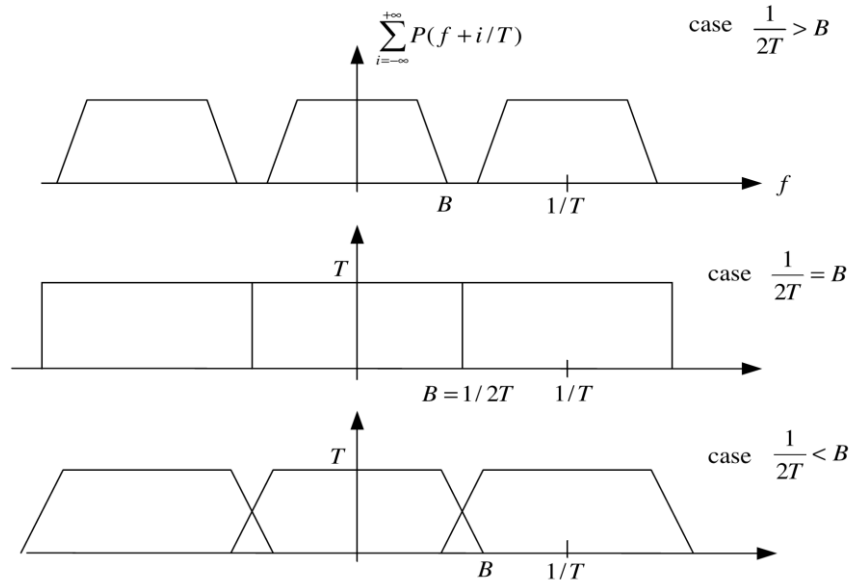

Figure.3.3. Frequency responses of Nyquist criterion cases

The frequency response of a raised cosine filter is:

$$p(f) = \begin{cases} T & \text{if } 0 \leq |f| \leq \frac{1-\alpha}{2T} \\ T \cos^2\left(\frac{\pi}{4\alpha}(2fT - (1-\alpha))\right) & \text{if } \frac{1-\alpha}{2T} < |f| < \frac{1+\alpha}{2T} \\ 0 & \text{if } |f| \geq \frac{1+\alpha}{2T} \end{cases} \quad (3.13)$$

Where α is the roll-off factor, lying between 0 and 1. The perfect lowpass filter with minimum bandwidth is obtained when $\alpha = 0$ and the bandwidth is maximum when $\alpha = 1$.

The frequency response of a raised cosine filter is represented in Figure.3.4 for $\alpha = 1$ and $\alpha = 0.35$.

Its impulse response $p(t)$ is given as:

$$p(t) = \text{sinc}(\pi t/T) \frac{\cos(\alpha \pi t/T)}{1 - 4\alpha^2 t^2/T^2} \quad (3.14)$$

The Figure.3.5 represent the Impulse response of the raised cosine filter for several values of α .

In practice, the raised cosine filter is separated into two identical receive and transmit filters called root raised cosine filters, whose frequency response is:

$$H_t(f) = H_r(f) = \sqrt{p(f)} = \begin{cases} \sqrt{T} & \text{if } 0 \leq |f| \leq \frac{1-\alpha}{2T} \\ \sqrt{T} \cos\left(\frac{\pi}{4\alpha}(2fT - (1-\alpha))\right) & \text{if } \frac{1-\alpha}{2T} < |f| < \frac{1+\alpha}{2T} \\ 0 & \text{if } |f| \geq \frac{1+\alpha}{2T} \end{cases} \quad (3.15)$$

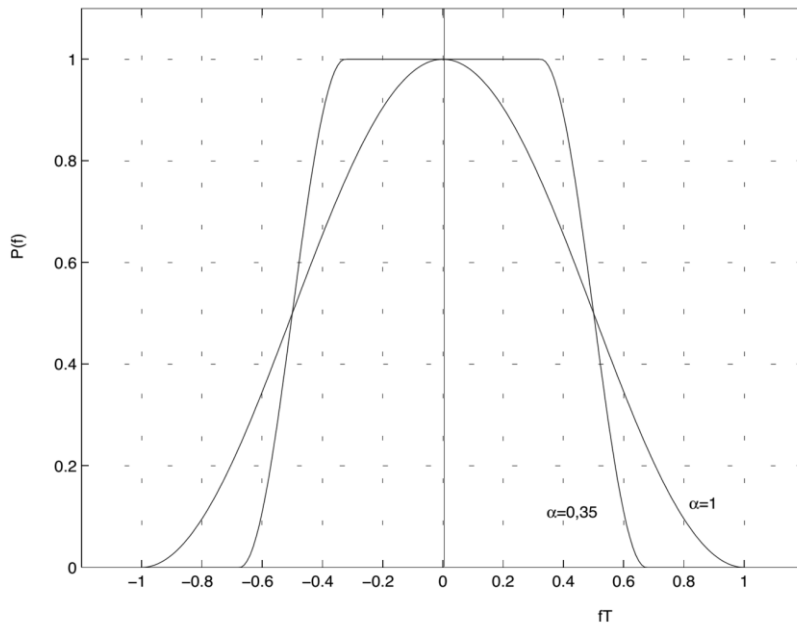

Figure.3.4. Frequency response of the raised cosine filter

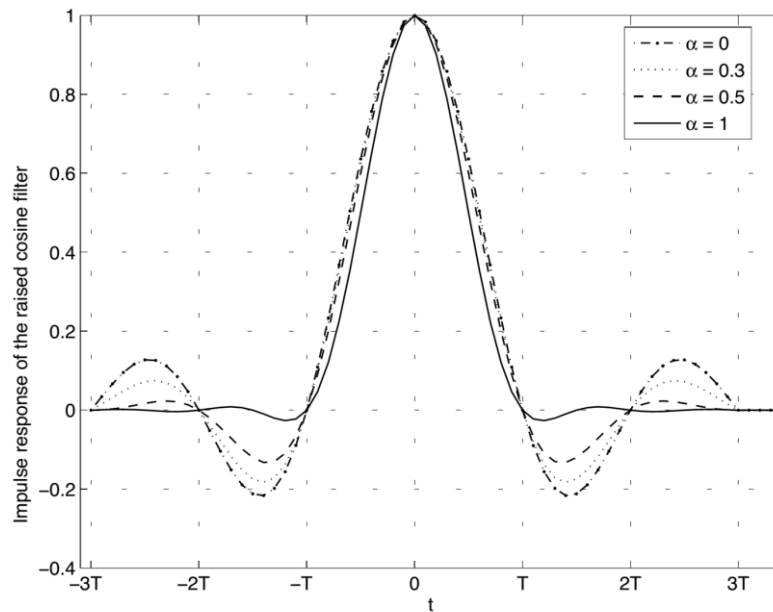

Figure.3.5. Impulse response of the raised cosine filter

3.4. Eye diagram

An eye pattern is a pattern displayed on the screen of an oscilloscope. The shape of this pattern resembles the shape of the human eye. therefore, it is called an eye pattern. The eye pattern is a practical way to study intersymbol interference and its effects on data communication system. The eye pattern is produced by the synchronized superposition of (as many as possible) successive symbol intervals of the distorted waveform appearing at the output of the receive filter as shown in Figure.3.6. The interior region of the eye pattern is called the eye-opening. The eye pattern provides a great deal of information about the performance of the system.

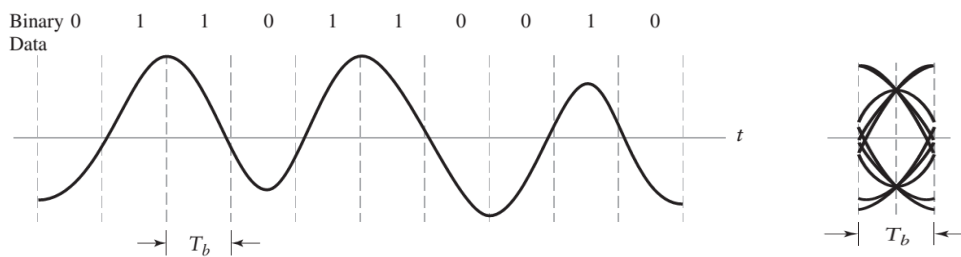

Figure.3.6. Eye diagram

The information obtained from Eye pattern (Figure.3.7) are:

- The width of the eye-opening defines the time interval over which the received wave can be sampled, without an error due to ISI. the best time for sampling is when the eye is open widest.
- The height of eye-opening at a specified sampling time defines the margin over the noise.
- When the effect of ISI is severe, the eye is completely closed and it is impossible to avoid error due to the combined presence of ISI and noise in the system.

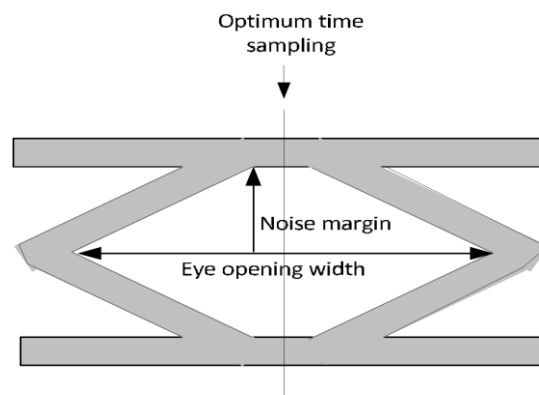

Figure.3.7. Information obtained from Eye pattern

Figures 3.8 and 3.9 show two examples for a binary signal ($a_k = \pm 1$) where the total filter is a raised cosine. The Figures graphically illustrate the impact of intersymbol interference and noise on the eye diagram. We can notice that even in the absence of noise, the chosen filter tends to close the eye diagram, which may make the decisions on the sampling time and on the symbol's amplitude more complicated.

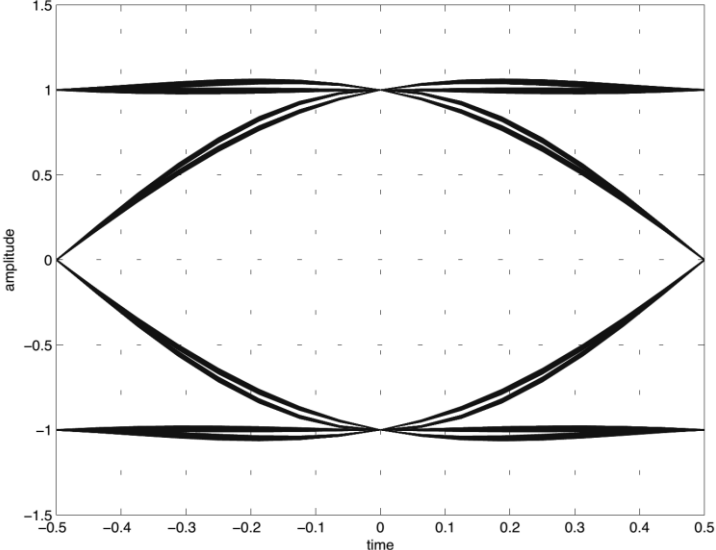

Figure.3.8. Eye diagram of binary signal with raised cosine filter for $\alpha = 1$

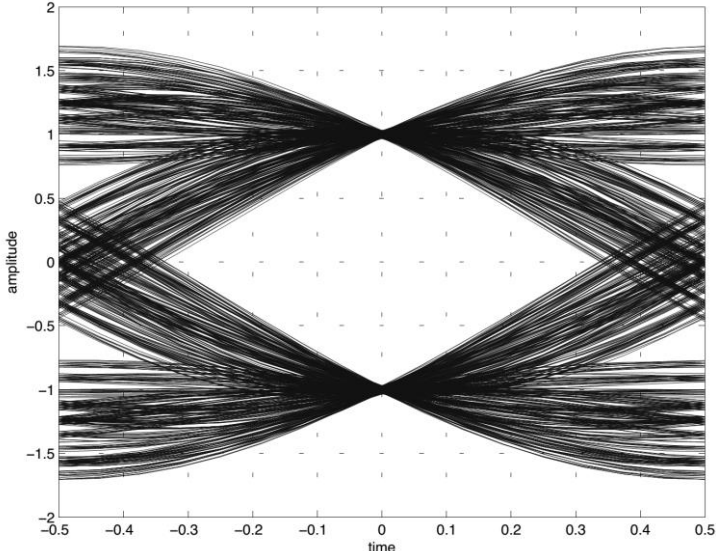

Figure.3.9. Eye diagram of binary signal with raised cosine filter for $\alpha = 0.35$

3.5. Exercises

Exercise 1:

We consider a baseband transmission with alphabet of 8 symbols on an AWGN channel, the bandwidth of the channel is $B = 70$ kHz. The power spectral density of the noise is $N_0/2$, the ratio $[E_b/N_0]$ dB (E_b is the energy per bit) is a function of the bit rate D_b as shown in the figure.3.9.

1) How many bits does each transmitted symbol carry?

2) To cancel intersymbol interference, we use raised cosine filtering with a Roll-Off factor $\alpha = 0.4$

The duration T_s of each symbol must then verify: $B \geq \frac{1+\alpha}{2T_s}$. Calculate the maximum rate D_{bmax} without ISI.

3) We want that the error probability per symbol do not exceed 10^{-5} . According to the curves below, does the bit rate previously calculated achieved this performance? If not, what is the value of the bit rate? Does it allow transmission without ISI?

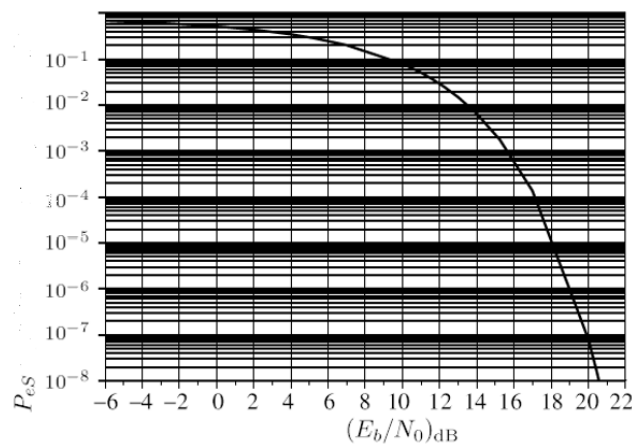
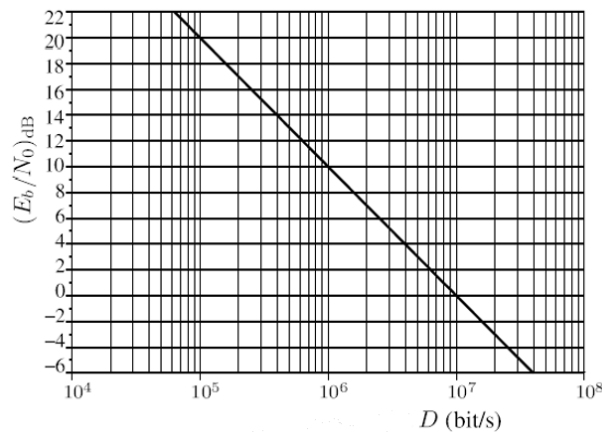

Chapter 4

Performance of Baseband Transmission

4.1. Binary Detection in AWGN Channel

For any binary channel, the transmitted signal over a symbol interval $[0, T]$ is represented by:

$$s_i(t) = \begin{cases} s_1(t) & 0 \leq t \leq T \quad \text{for a binary 1} \\ s_2(t) & 0 \leq t \leq T \quad \text{for a binary 0} \end{cases} \quad (4.1)$$

The signal at the output of the simplifier is:

$$z(T) = a_i(T) + n_0(T) \quad (4.2)$$

Where $n_0(T)$ is the noise.

The probability density function (PDF) of the Gaussian random noise n_0 is expressed as:

$$p(n_0) = \frac{1}{\sigma_0\sqrt{2\pi}} \exp\left[-\frac{1}{2}\left(\frac{n_0}{\sigma_0}\right)^2\right] \quad (4.3)$$

Where σ_0^2 is the noise variance.

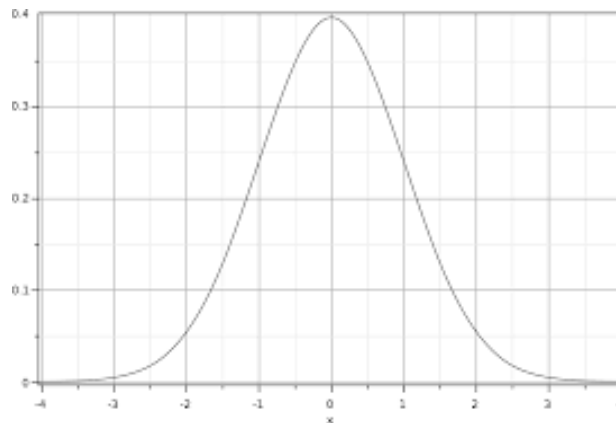

Figure.4.1. Gaussian distribution

The conditional PDFs $p(z/s_1)$ and $p(z/s_2)$ can be expressed as:

$$p(z/s_1) = \frac{1}{\sigma_0\sqrt{2\pi}} \exp\left[-\frac{1}{2}\left(\frac{z - a_1}{\sigma_0}\right)^2\right] \quad (4.3)$$

and

$$p(z/s_2) = \frac{1}{\sigma_0\sqrt{2\pi}} \exp\left[-\frac{1}{2}\left(\frac{z - a_2}{\sigma_0}\right)^2\right] \quad (4.4)$$

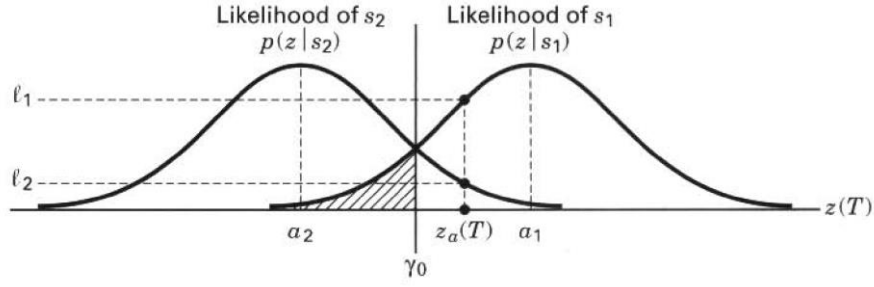

Figure.4.2. The conditional PDFs $p(z/s_1)$ and $p(z/s_2)$

The detection is performed by choosing the hypotheses that results from the threshold measurement:

$$\begin{matrix} H_1 \\ z(T) > \gamma_0 \\ H_2 \end{matrix} \quad (4.5)$$

where H_1 and H_2 are the two possible binary hypotheses.

H_1 is chosen if $z(T) > \gamma$, and it is equivalent to deciding that the signal $s_1(t)$ was sent.

H_2 is chosen if $z(T) < \gamma$, and it is equivalent to deciding that the signal $s_2(t)$ was sent.

4.2. Maximum Likelihood (ML) Detector

Based on the MAP criterion, we obtain:

if $p(s_1/z) > p(s_2/z) \Rightarrow H_1$, if not $p(s_2/z) > p(s_1/z) \Rightarrow H_2$, we can write this as:

$$\begin{matrix} H_1 \\ p(s_1/z) > p(s_2/z) \\ H_2 \end{matrix} \quad (4.6)$$

using Bayes theorem:

$$p(s_i/z) = \frac{p(z/s_i)p(s_i)}{p(z)} \quad (4.7)$$

we obtain:

$$\begin{matrix} H_1 \\ \frac{p(z/s_1)p(s_1)}{p(z)} > \frac{p(z/s_2)p(s_2)}{p(z)} \\ H_2 \end{matrix} \quad (4.8)$$

If the symbols are equally probable $p(s_1) = p(s_2)$:

$$\underset{H_2}{p(z/s_1)} \underset{H_2}{\overset{H_1}{>}} \underset{H_2}{p(z/s_2)} \quad (4.9)$$

$$\frac{\underset{H_2}{p(z/s_1)}}{\underset{H_2}{p(z/s_2)}} \underset{H_2}{\overset{H_1}{>}} 1 \quad (4.10)$$

Now, substituting the likelihood $p(z/s_1)$ and $p(z/s_2)$ from equations (4.3) and (4.4), we obtain:

$$\exp \left[\frac{(z - a_2)^2}{2\sigma_0^2} - \frac{(z - a_1)^2}{2\sigma_0^2} \right] \underset{H_2}{\overset{H_1}{>}} 1 \quad (4.11)$$

applying the \ln and after some simplifications, the detection rule is obtained as follow:

$$\underset{H_2}{z} \underset{H_2}{\overset{H_1}{>}} \frac{a_1 + a_2}{2} = \gamma_0 \text{ (threshold)} \quad (4.12)$$

4.3. Error Probability

The error probability when $s_1(t)$ was sent is:

$$p(e/s_1) = p(H_2/s_1) = \int_{-\infty}^{\gamma_0} p(z/s_1) dz \quad (4.13)$$

Similarly, the error probability when $s_2(t)$ was sent is:

$$p(e/s_2) = p(H_1/s_2) = \int_{\gamma_0}^{+\infty} p(z/s_2) dz \quad (4.14)$$

So, the global error is the sum of the probabilities:

$$\begin{aligned} p_B &= \sum_{i=1}^2 p(e, s_i) = \sum_{i=1}^2 p(e/s_i)p(s_i) \\ &= p(e/s_1)p(s_1) + p(e/s_2)p(s_2) \\ &= p(H_2/s_1)p(s_1) + p(H_1/s_2)p(s_2) \end{aligned} \quad (4.15)$$

For the case where the symbols are equiprobable $p(s_1) = p(s_2)$:

$$p_B = \frac{1}{2}p(H_2/s_1) + \frac{1}{2}p(H_1/s_2) \quad (4.16)$$

and because of the symmetry of the PDFs:

$$p_B = p(H_2/s_1) = p(H_1/s_2) \quad (4.17)$$

$$\begin{aligned} p_B &= \int_{\gamma_0}^{+\infty} p(z/s_2) dz \\ &= \int_{\gamma_0}^{+\infty} \frac{1}{\sigma_0 \sqrt{2\pi}} \exp\left[-\frac{1}{2} \left(\frac{z - a_2}{\sigma_0}\right)^2\right] dz \end{aligned} \quad (4.18)$$

In order to evaluate this integral we use the complimentary error function $Q(x)$ given as:

$$Q(x) = \int_x^{+\infty} \frac{1}{\sqrt{2\pi}} \exp\left[-\frac{u^2}{2}\right] du \quad (4.19)$$

$$\text{let } u = \frac{z - a_2}{\sigma_0} \Rightarrow dz = \sigma_0 du$$

$$z \rightarrow +\infty \Rightarrow u \rightarrow +\infty$$

$$z = \gamma = \frac{a_1 + a_2}{2} \Rightarrow u = \frac{z - a_2}{\sigma_0} = \frac{a_1 - a_2}{2\sigma_0}$$

$$\begin{aligned} p_B &= \int_{\frac{a_1 - a_2}{2\sigma_0}}^{+\infty} \frac{1}{\sigma_0 \sqrt{2\pi}} \exp\left[-\frac{u^2}{2}\right] \sigma_0 du \\ &= Q\left(\frac{a_1 - a_2}{2\sigma_0}\right) \end{aligned} \quad (4.20)$$

The error probability can be approximated using the nearest neighbor approximation as:

$$p_B \approx \frac{1}{M} \sum_{n=1}^N N_n Q\left(\sqrt{\frac{d_{min}^2}{2N_0}}\right) \quad (4.21)$$

where M is the number of signals and N_n is the number of neighbors at distance d_{min} , N_0 is the power spectral density PSD of the noise.

In our case:

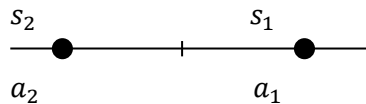

$$M = 2, N = 1$$

$$d_{min} = a_1 - a_2$$

$$N_0 = 2\sigma_0^2$$

$$p_B \approx \frac{1}{2}(1 + 1)Q\left(\sqrt{\frac{(a_1 - a_2)^2}{2(2\sigma_0^2)}}\right) = Q\left(\frac{a_1 - a_2}{2\sigma_0}\right) \quad (4.22)$$

This error probability can be rewritten in terms of the difference energy between the signals s_1 and s_2 as:

We have $E_d = (a_1 - a_2)^2$ and $\sigma_0^2 = \frac{N_0}{2}$, so:

$$p_B = Q\left(\sqrt{\frac{E_d}{2N_0}}\right) \quad (4.23)$$

The E_d can be expressed as:

$$E_d = \int_0^T [s_1(t) - s_2(t)]^2 dt = \int_0^T s_1^2(t) dt + \int_0^T s_2^2(t) dt - 2 \int_0^T s_1(t)s_2(t) dt$$

-For antipodal signal

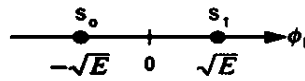

$$E_d = \int_0^T s_1^2(t) dt + \int_0^T s_2^2(t) dt - 2 \int_0^T s_1(t)s_2(t) dt = E_b + E_b + 2E_b = 4E_b$$

$$p_B = Q\left(\sqrt{\frac{2E_b}{N_0}}\right) \quad (4.24)$$

-For orthogonal signal

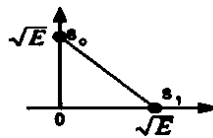

$$E_d = \int_0^T s_1^2(t) dt + \int_0^T s_2^2(t) dt - 2 \int_0^T s_1(t)s_2(t) dt = E_b + E_b + 0 = 2E_b$$

$$p_B = Q\left(\sqrt{\frac{E_b}{N_0}}\right) \quad (4.25)$$

-For unipolar signal

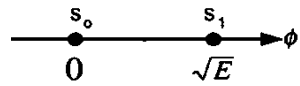

$$E_d = \int_0^T s_1^2(t)dt + \int_0^T s_2(t)dt - 2 \int_0^T s_1(t)s_2(t)dt = E_b + 0 + 0 = E_b$$

$$p_B = Q\left(\sqrt{\frac{E_b}{2N_0}}\right) \tag{4.26}$$

We observe that antipodal signals offer better performance compared to orthogonal signals (Figure.4.3).

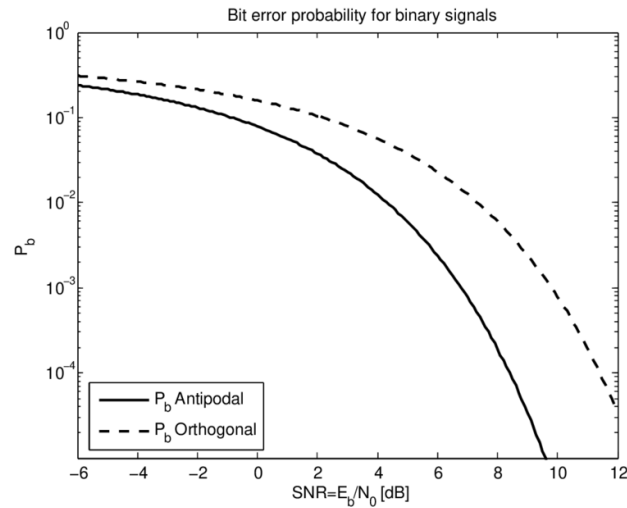

Figure.4.3. Error probability of antipodal and orthogonal signals

The values of the $Q(x)$ function for $0 \leq x \leq 9$ are given in the Table 4.1 below:

Table 4.1: Values of $Q(x)$ for $0 \leq x \leq 9$

x	$Q(x)$	x	$Q(x)$	x	$Q(x)$	x	$Q(x)$
0.00	0.5	2.30	0.010724	4.55	2.6823×10^{-6}	6.80	5.231×10^{-12}
0.05	0.48006	2.35	0.0093867	4.60	2.1125×10^{-6}	6.85	3.6925×10^{-12}
0.10	0.46017	2.40	0.0081975	4.65	1.6597×10^{-6}	6.90	2.6001×10^{-12}
0.15	0.44038	2.45	0.0071428	4.70	1.3008×10^{-6}	6.95	1.8264×10^{-12}
0.20	0.42074	2.50	0.0062097	4.75	1.0171×10^{-6}	7.00	1.2798×10^{-12}
0.25	0.40129	2.55	0.0053861	4.80	7.9333×10^{-7}	7.05	8.9459×10^{-13}
0.30	0.38209	2.60	0.0046612	4.85	6.1731×10^{-7}	7.10	6.2378×10^{-13}
0.35	0.36317	2.65	0.0040246	4.90	4.7918×10^{-7}	7.15	4.3389×10^{-13}
0.40	0.34458	2.70	0.003467	4.95	3.7107×10^{-7}	7.20	3.0106×10^{-13}
0.45	0.32636	2.75	0.0029798	5.00	2.8665×10^{-7}	7.25	2.0839×10^{-13}
0.50	0.30854	2.80	0.0025551	5.05	2.2091×10^{-7}	7.30	1.4388×10^{-13}
0.55	0.29116	2.85	0.002186	5.10	1.6983×10^{-7}	7.35	9.9103×10^{-14}
0.60	0.27425	2.90	0.0018658	5.15	1.3024×10^{-7}	7.40	6.8092×10^{-14}
0.65	0.25785	2.95	0.0015889	5.20	9.9644×10^{-8}	7.45	4.667×10^{-14}
0.70	0.24196	3.00	0.0013499	5.25	7.605×10^{-8}	7.50	3.1909×10^{-14}
0.75	0.22663	3.05	0.0011442	5.30	5.7901×10^{-8}	7.55	2.1763×10^{-14}
0.80	0.21186	3.10	0.0009676	5.35	4.3977×10^{-8}	7.60	1.4807×10^{-14}
0.85	0.19766	3.15	0.00081635	5.40	3.332×10^{-8}	7.65	1.0049×10^{-14}
0.90	0.18406	3.20	0.00068714	5.45	2.5185×10^{-8}	7.70	6.8033×10^{-15}
0.95	0.17106	3.25	0.00057703	5.50	1.899×10^{-8}	7.75	4.5946×10^{-15}
1.00	0.15866	3.30	0.00048342	5.55	1.4283×10^{-8}	7.80	3.0954×10^{-15}
1.05	0.14686	3.35	0.00040406	5.60	1.0718×10^{-8}	7.85	2.0802×10^{-15}
1.10	0.13567	3.40	0.00033693	5.65	8.0224×10^{-9}	7.90	1.3945×10^{-15}
1.15	0.12507	3.45	0.00028029	5.70	5.9904×10^{-9}	7.95	9.3256×10^{-16}
1.20	0.11507	3.50	0.00023263	5.75	4.4622×10^{-9}	8.00	6.221×10^{-16}
1.25	0.10565	3.55	0.00019262	5.80	3.3157×10^{-9}	8.05	4.1397×10^{-16}
1.30	0.0968	3.60	0.00015911	5.85	2.4579×10^{-9}	8.10	2.748×10^{-16}
1.35	0.088508	3.65	0.00013112	5.90	1.8175×10^{-9}	8.15	1.8196×10^{-16}
1.40	0.080757	3.70	0.0001078	5.95	1.3407×10^{-9}	8.20	1.2019×10^{-16}
1.45	0.073529	3.75	8.8417×10^{-5}	6.00	9.8659×10^{-10}	8.25	7.9197×10^{-17}
1.50	0.066807	3.80	7.2348×10^{-5}	6.05	7.2423×10^{-10}	8.30	5.2056×10^{-17}
1.55	0.060571	3.85	5.9059×10^{-5}	6.10	5.3034×10^{-10}	8.35	3.4131×10^{-17}
1.60	0.054799	3.90	4.8096×10^{-5}	6.15	3.8741×10^{-10}	8.40	2.2324×10^{-17}
1.65	0.049471	3.95	3.9076×10^{-5}	6.20	2.8232×10^{-10}	8.45	1.4565×10^{-17}
1.70	0.044565	4.00	3.1671×10^{-5}	6.25	2.0523×10^{-10}	8.50	9.4795×10^{-18}
1.75	0.040059	4.05	2.5609×10^{-5}	6.30	1.4882×10^{-10}	8.55	6.1544×10^{-18}
1.80	0.03593	4.10	2.0658×10^{-5}	6.35	1.0766×10^{-10}	8.60	3.9858×10^{-18}
1.85	0.032157	4.15	1.6624×10^{-5}	6.40	7.7688×10^{-11}	8.65	2.575×10^{-18}
1.90	0.028717	4.20	1.3346×10^{-5}	6.45	5.5925×10^{-11}	8.70	1.6594×10^{-18}
1.95	0.025588	4.25	1.0689×10^{-5}	6.50	4.016×10^{-11}	8.75	1.0668×10^{-18}
2.00	0.02275	4.30	8.5399×10^{-6}	6.55	2.8769×10^{-11}	8.80	6.8408×10^{-19}
2.05	0.020182	4.35	6.8069×10^{-6}	6.60	2.0558×10^{-11}	8.85	4.376×10^{-19}
2.10	0.017864	4.40	5.4125×10^{-6}	6.65	1.4655×10^{-11}	8.90	2.7923×10^{-19}
2.15	0.015778	4.45	4.2935×10^{-6}	6.70	1.0421×10^{-11}	8.95	1.7774×10^{-19}
2.20	0.013903	4.50	3.3977×10^{-6}	6.75	7.3923×10^{-12}	9.00	1.1286×10^{-19}
2.25	0.012224						

For $x > 3$ the values of $Q(x)$ can be calculated approximately by:

$$Q(x) = \frac{1}{x\sqrt{2\pi}} \exp\left(-\frac{x^2}{2}\right)$$

4.4. Exercises

Exercise 1:

We consider the transmission of binary equiprobable symbols over AWGN channel. After matched filtering and sampling, the received sample is $z = s_i + b$, where b is Gaussian noise with the probability

density function defined as: $p(b) = \frac{1}{\sigma\sqrt{2\pi}} \exp\left(-\frac{1}{2}\left(\frac{b}{\sigma}\right)^2\right)$ with zero mean and variance $\sigma_0^2 = \frac{N_0}{2}$, ($\frac{N_0}{2}$: is PSD). The constellation of the received signals is:

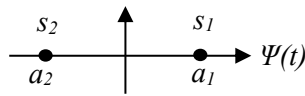

- 1- Express the conditional PDFs $p(z/s_i)$ then plot them in the same figure.
- 2- Formulate the decision rule using the Maximum Likelihood detector.
- 3- Express the error probability per bit as a function of d_{12} (the distance between the two points s_1 and s_2) and N_0 . Make the numerical application in the case: $a_1 = 2, a_2 = -2$ and $N_0 = 2$.

Exercise 2:

A binary digital communication system employs the signals:

$$s_0(t) = 0; \quad 0 \leq t \leq T$$

$$s_1(t) = A; \quad 0 \leq t \leq T$$

For transmitting the information. This is called on-off signaling. The receiver correlates the received signal $r(t)$ with $s(t)$ and samples the output at $t + T$.

- 1-Determine the optimum detector for an AWGN channel assuming that the signals are equally probable.
- 2-Determine the probability of error as a function of the SNR. How does on-off signaling compare with antipodal signaling?

Exercise 3:

Consider a signal detector with an input:

$$r = \mp A + n$$

where $+A$ and $-A$ occur with equal probability and the noise variable n is characterized by the (Laplacian) PDF shown in Figure below.

1. Determine the probability of error as a function of the parameters A and σ .
2. Determine the SNR required to achieve an error probability of 10^{-5} . How does the SNR compare with the result for a Gaussian PDF?

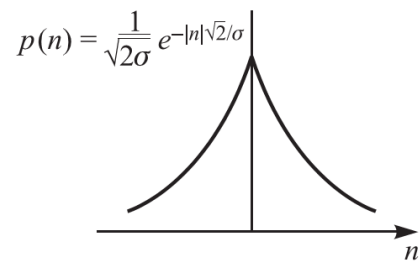

Laplacian PDF

Chapter 5

Narrowband Digital Modulations

5.1. Introduction

The process of mapping a digital sequence to signals for transmission over a communication channel is called digital modulation. In a digital modulation scheme, the binary sequence is parsed into sub-sequences of length k , and each sub-sequence is mapped into one of the $s_m(t)$, $1 \leq k \leq 2^k$, signals. This modulation scheme is equivalent to a mapping from $M = 2^k$ messages to M possible signals, as shown in Figure.5.1.



Figure.5.1. Digital modulation

The general form of the carrier wave is:

$$s(t) = A(t) \cos[w_0 t + \phi(t)] \quad (5.1)$$

where $A(t)$ is the amplitude, w_0 is the radian frequency and $\phi(t)$ is the phase.

5.2. Amplitude Shift Keying (ASK)

ASK modulations are linear modulations that only modify the amplitude of the signal. The general analytic expression is:

$$s_i(t) = \sqrt{\frac{2E_i}{T}} \cos(w_0 t + \phi) \quad \begin{array}{l} 0 \leq t \leq T \\ i = 1, \dots, M \end{array} \quad (5.2)$$

where the amplitude $\sqrt{\frac{2E_i}{T}}$ takes M discrete values. The phase ϕ is an arbitrary constant.

The general form of the amplitude $\sqrt{\frac{2E}{T}}$ is derived as:

$$s(t) = A \cos wt$$

where A is the peak value of the waveform.

$$A = \sqrt{2} A_{rms}$$

where A_{rms} is the root mean square value.

$$s(t) = \sqrt{2}A_{rms} \cos wt$$

$$= \sqrt{2A_{rms}^2} \cos wt$$

$$s(t) = \sqrt{2P} \cos wt$$

where $A_{rms}^2 = P$ is the average power. Replacing P watts by E joules/ T seconds we get:

$$s(t) = \sqrt{\frac{2E}{T}} \cos wt$$

The $M = 2^n$ symbols set can be chosen as follow:

$$C = \{-(M-1), -(M-3), \dots, -1, 1, \dots, (M-3), (M-1)\}A \quad (5.3)$$

During the symbol time T , the transmitted symbol takes a value from C .

5.2.1. B-ASK (Binary ASK)

In this case, the amplitude takes two values $\sqrt{\frac{2E}{T}}$ and 0 Figure5.2. It called also OOK (On-Off Keying),

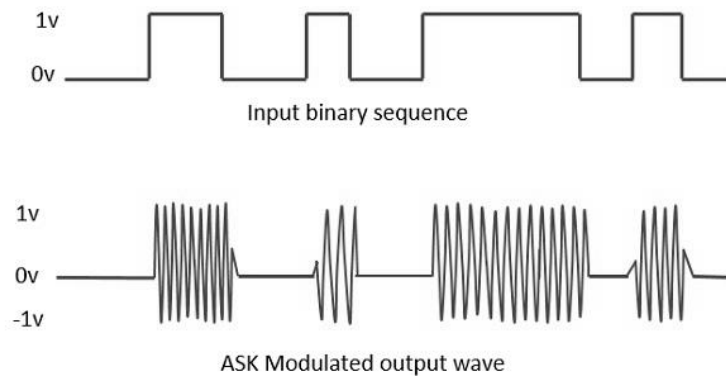

Figure.5.2. OOK modulation

5.2.2. Constellation Diagram

The constellation is the representation in the complex plane of all the points associated with the modulated symbols.

We have:

$$s(t) = A \cos(\omega_0 t + \varphi)$$

$$= A \cos(\omega_0 t) \cos(\varphi) - A \sin(\omega_0 t) \sin(\varphi)$$

$$s(t) = I \cos(\omega_0 t) + Q \sin(\omega_0 t) \tag{5.4}$$

We have two bases set functions $\phi_1(t) = \cos(\omega_0 t)$ and $\phi_2(t) = \sin(\omega_0 t)$. The signal $s(t)$ is represent as point as shown in the Figure.5.3.

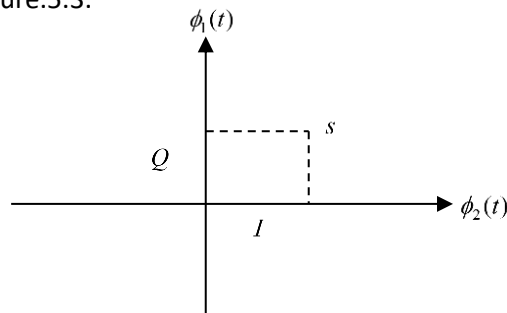

Figure.5.3. Constellation

The Figures.5.3 and 5.4 represent two examples of ASK modulations of orders 4 and 8.

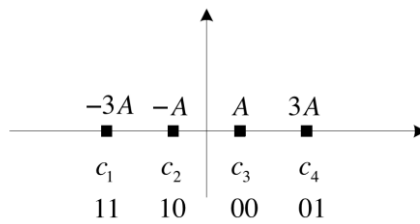

Figure.5.4. 4-ASK modulation

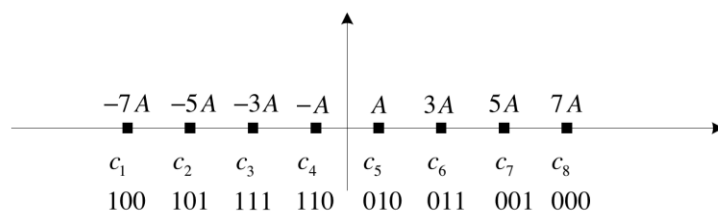

Figure.5.5. 8-ASK modulation

The important characteristic of a constellation is the minimum Euclidean distance between two points in the constellation d_{min} .

$$d_{min} = \min_{k \neq j} d_{kj} \text{ where } d_{kj}^2 = |c_k - c_j|^2$$

5.2.3. Detection of B-ASK Signals

-Noncoherent Detection of B-ASK Signals:

The receiver consists of a band-pass filter, followed by an envelope detector, then a sampler, and finally a decision-making device, as depicted in Figure.5.6. The band-pass filter produces a pulsed sinusoid for symbol 1 and, ideally, no output for symbol 0. Next, the envelope detector traces the envelope of the filtered version of the B-ASK signal. Finally, the decision-making device working in conjunction with the sampler, regenerates the original binary data stream by comparing the sampled envelope-detector output against a preset threshold every T seconds.

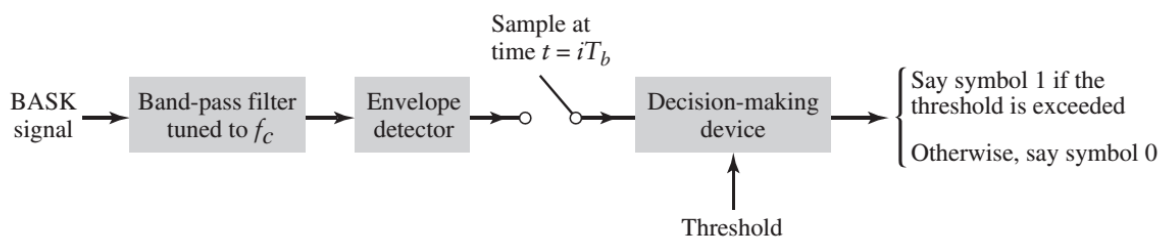

Figure.5.6. Noncoherent detection of B-ASK

-Coherent Detection of B-ASK Signals:

The block diagram of the coherent detection of B-ASK signals is given in Figure5.4. To detect the original binary sequence of 1 and 0, the BASK signal at the channel output is applied to a receiver that consists of four sections, as depicted in Figure.5.7.

- (i) Product modulator, which is also supplied with a locally generated reference signal that is a replica of the carrier wave.
- (ii) Low-pass filter, designed to remove the double-frequency components of the product modulator output and pass the zero-frequency components.
- (iii) Sampler, which uniformly samples the output of the low-pass filter at where the local clock governing the operation of the sampler is synchronized with the clock responsible for bit-timing in the transmitter.
- (iv) Decision-making device, which compares the sampled value of the low-pass filter's output to an externally supplied threshold, every seconds. If the threshold is exceeded, the device decides in favor of symbol 1; otherwise, it decides in favor of symbol 0.

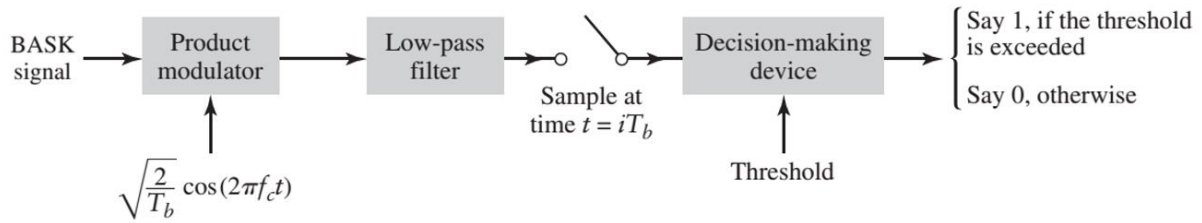

Figure.5.7. Coherent detection of BASK

5.3. Frequency Shift Keying (FSK)

The general analytic expression of the FSK modulation is given as:

$$s_i(t) = \begin{cases} \sqrt{\frac{2E}{T}} \cos(w_i t + \varphi) & 0 \leq t \leq T \\ & i = 1, \dots, M \end{cases} \quad (5.5)$$

where the frequency w_i has M discrete values and the phase φ is an arbitrary constant. The Figure.5.8 shows example of FSK modulation.

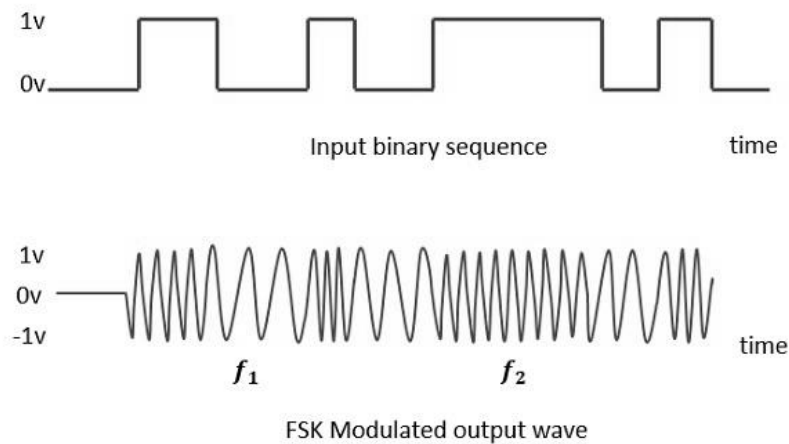

Figure5.8. FSK modulation

5.3.1. Noncoherent Detection of B-FSK Signals

The receiver consists of two paths, one dealing with f_1 frequency (i.e., symbol 1) and the other dealing with f_2 frequency (i.e., symbol 0), Figure.5.9:

-Path 1 uses a band-pass filter of mid-band frequency f_1 . The filtered version of the incoming B-FSK signal is envelope-detected and then sampled at time $t = iT_b$ to produce the output v_1 .

-Path 2 uses a band-pass filter of mid-band frequency f_1 . The filtered version of the BFSK signal is envelope-detected sampled at time $t = iT$ to produce the output v_2 .

The outputs of the two paths, v_1 and v_2 are applied to a comparator, where decisions on the composition of the B-FSK signal are repeated every T_b seconds. Recognizing that the upper path corresponds to symbol 1 and the lower path corresponds to symbol 0, the comparator decides in favor of symbol 1 if v_1 is greater than v_2 at the specified bit-timing instant; otherwise, the decision is made in favor of symbol 0.

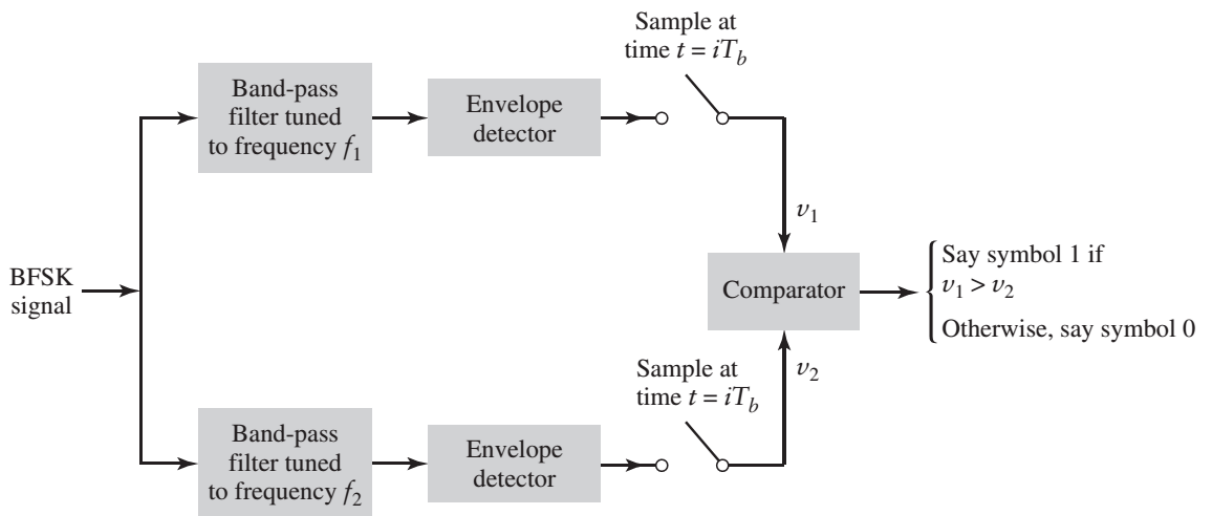

Figure5.9. Noncoherent detection of BFSK

5.4. Phase Shift Keying (PSK)

The general analytic expression of PSK is:

$$s_i(t) = \sqrt{\frac{2E}{T}} \cos(\omega_0 t + \varphi_i) \quad \begin{matrix} 0 \leq t \leq T \\ i = 1, \dots, M \end{matrix} \quad (5.6)$$

where the phase φ_i takes M discrete values, typically given as:

$$\varphi_i = \frac{2\pi i}{M}, \quad i = 1, \dots, M \quad (5.7)$$

The Figure.5.10 shows the principle of PSK modulation.

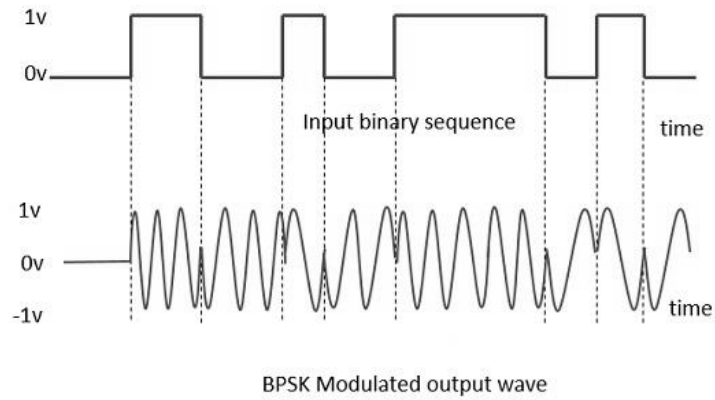

Figure.5.10. PSK modulation

The Figure.5.11. shows the constellations of B-PSK, Q-PSK and 8-PSK.

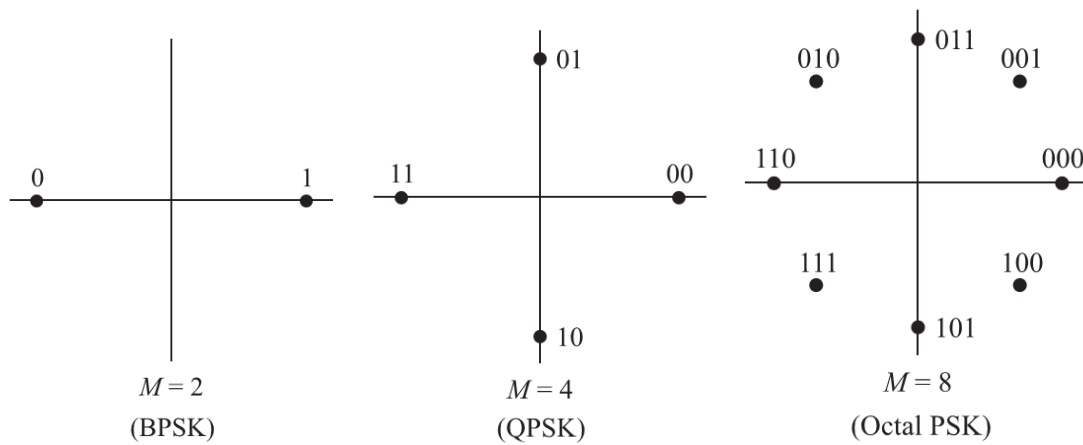

Figure.5.11. Constellations of B-PSK, Q-PSK and 8-PSK.

5.5. Quadrature Amplitude Modulation (QAM)

Quadrature phase amplitude modulation is a technique that employs a combination of phase and amplitude modulation. The Figure.5.12. shows example of 4-QAM modulation.

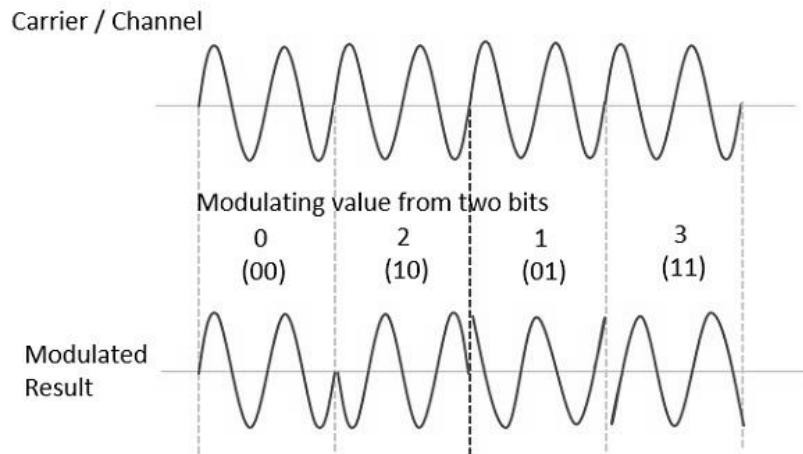

Figure.5.12. 4-QAM modulation

The Figure5.13. illustrates examples of constellations of 8-QAM and 16-QAM.

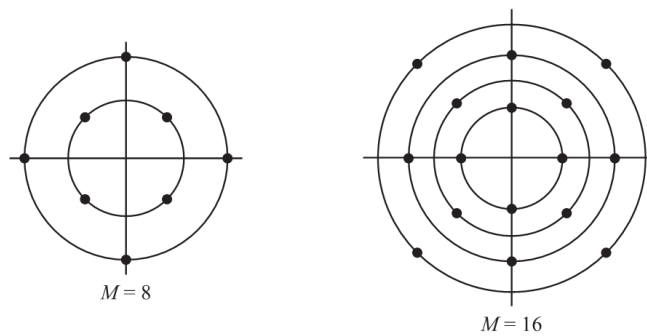

Figure.5.13. 8-QAM and 16-QAM constellations

5.6. IQ Modulator/Detector

5.6.1. IQ Modulator

To generate the IQ signal, the incoming binary data stream is first converted into polar form by a non-return-to-zero level encoder. The resulting binary wave is next divided by means of a demultiplexer (consisting of a serial-to-parallel converter) into two separate binary waves consisting of the odd- and even numbered input bits. The demultiplexed binary waves $a_1(t)$ and $a_2(t)$ are used to modulate the pair of quadrature carriers. Finally, the two BPSK signals are subtracted to produce the desired QPSK signals, as depicted in Figure.5.14.

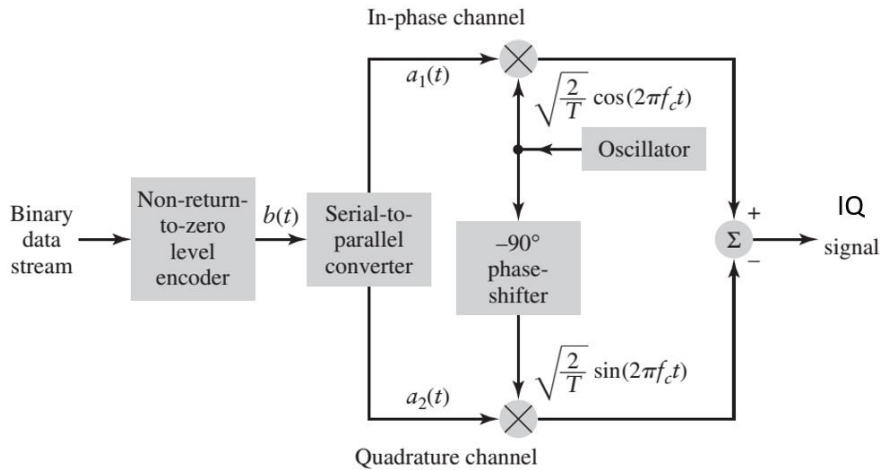

Figure.5.14. IQ Modulator

5.6.2. IQ Detector

The IQ receiver consists of an in-phase (I)-channel and quadrature (Q)-channel with a common input, as depicted in Figure.5.15. Each channel is itself made up of a product modulator, low-pass filter, sampler, and decision-making device. Under ideal conditions, the I- and Q-channels of the receiver, respectively, recover the demultiplexed components $a_1(t)$ and $a_2(t)$ responsible for modulating the orthogonal pair of carriers in the transmitter. Applying the outputs of these two channels to a multiplexer (consisting of a parallel-to-serial converter), the receiver recovers the original binary sequence.

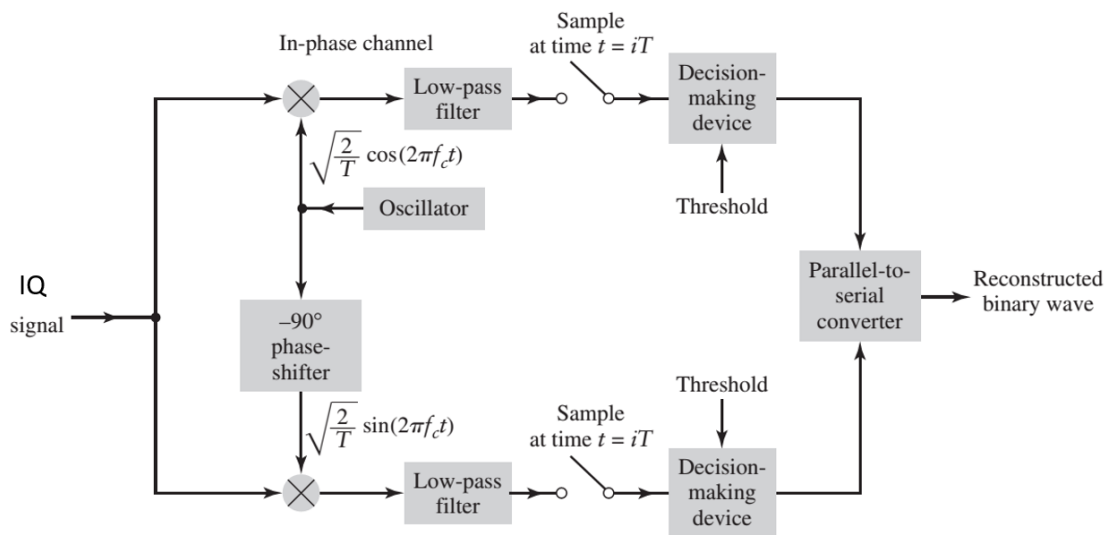

Figure.5.15. IQ Detector

5.7. Exercises

Exercise 1:

We consider 4-QAM modulation where its constellation is depicted below, with $A=0.5V$, $f_0=5$ KHz and the symbol time is $T_s=0.4$ ms.

In order to generate the modulate signal V_{4-QAM} , we use the modulator below, where $V_0=E_0\cos(2\pi f_0 t)$ and $E_0=2$ V.

1- Express the V_i signal levels as a function of E_0 , A and K parameters.

2- Represent the V_i signal and the V_{4-QAM} signal when the binary sequence to be transmitted is as follows : 01, 10, 00, 11, 01, 00.

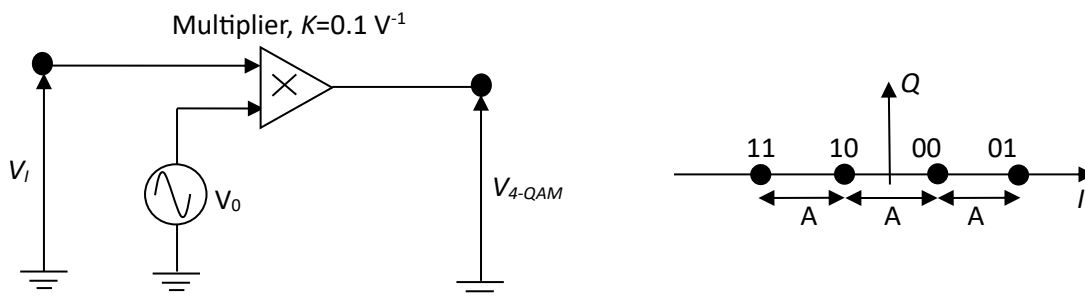

Exercise 2:

Consider the chronogram of a B-PSK transmission, where the vertical dotted lines separate the bits.

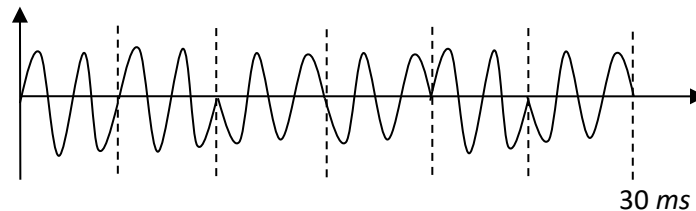

Determine:

-The transmitted bits.

-The bit rate.

-The bandwidth for this transmission.

Exercise 3:

Consider the IQ demodulation system shown in the following figure, assuming that $s(t) = s_I(t) \sin(2\pi f_c t) - s_Q(t) \cos(2\pi f_c t)$. The phase shifts in the carriers are non-zero but known.

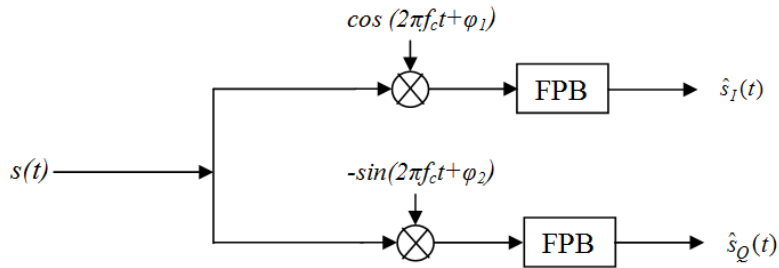

- Express the demodulator outputs as a function of the original signals $s_I(t)$ and $s_Q(t)$.

Exercise 4:

Consider the two following constellations:

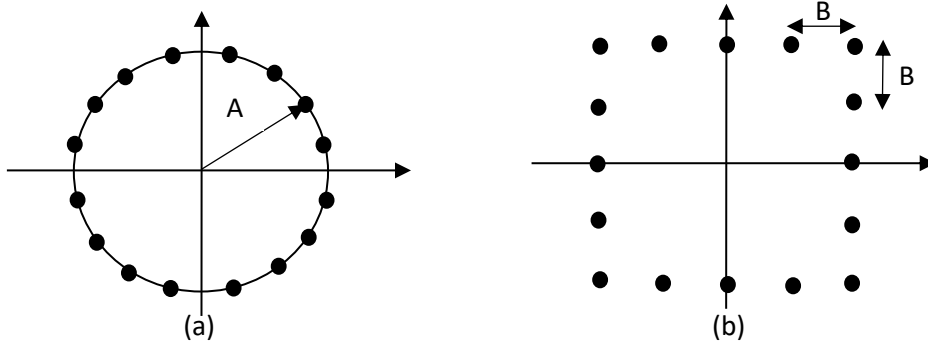

- 1- What is the type of modulation corresponding to each constellation? justify?
- 2- Determine the minimum distance d_{min} for the two constellations.
- 3- Determine the average energy per symbol for the two constellations.
- 4- Determine the error probability of the two constellations.

Exercise 5:

Consider the two digital modulations 16-QAM and 16-PSK. The minimum distance in the 16-QAM constellation is $2B$. The points of the 16-PSK constellation are located on a circle of radius A .

- 1- Determine the energy per symbol and the energy per bit for the two constellations.
- 2- Assuming that A is fixed, express B as a function of A so that the energy per symbol of 16-QAM is equal to the energy per symbol of 16-PSK. Comparing the minimum distance for the two constellations, what can we deduce about the performance?

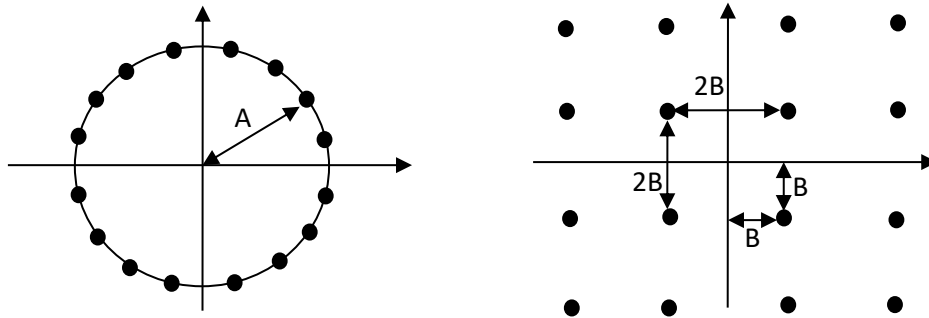

Exercise 6:

Assuming that binary PSK is used for transmitting information over an AWGN with a power spectral density of $\frac{N_0}{2} = 10^{-10}$ W/Hz. The transmitted signal energy is $E_b = \frac{1}{2}A^2T$, where T is the bit interval and A is the signal amplitude. Determine the signal amplitude required to achieve an error probability of 10^{-6} when the data rate is:

- 1) 10 Kbits/s
- 2) 100 Kbits/s
- 3) 1 Mbits/s

References

- [1] John B., "Anderson-Digital transmission engineering", IEEE Press_ Wiley-Interscience (2005).
- [2] John G. Proakis, "Masoud Salehi - Digital Communications", 5th Edition -McGraw-Hill (2007).
- [3] Mylène Pischella, Didier Le Ruyet, "Digital Communications 2_ Digital Modulations", Wiley-ISTE (2015).
- [4] Sklar, Bernard, "Digital communications: fundamentals and applications", Pearson, (2021).
- [5] Madhow, U., "Fundamentals of digital communication", Cambridge University Press. (2008).
- [6] Robert G. Gallager, "Principles of digital communication", Cambridge University Press (2008).
- [7] C.C. Bissell, D.A. Chapman, "Digital signal transmission", Cambridge University Press (1992).
- [8] Haykin, Simon, and Michael Moher, "Introduction to analog and digital communications", John Wiley & Sons, Inc., (2007).
- [9] Amos Lapidot-A, "Foundation in Digital Communication", Cambridge University Press (2009).