



23 فيزي 2025

المسيلة في :

رقم: 2025/ق.ه.ك/...

شهادة إدارية

بخصوص مطبوعة الدروس الخاصة بالأستاذ

رواجي رياض

بناءً على محضر اللجنة العلمية لقسم الهندسة الكهربائية تحت رقم: 365/ق.ه.ك/2024 المنعقد بتاريخ 06 نوفمبر 2024 والمتضمن تعيين الخبراء: الأستاذ حريزي عبد الغفور أستاذ محاضر-أ- بجامعة المسيلة الأستاذ واقني فيصل أستاذ محاضر-أ- بجامعة المسيلة، والأستاذ رواج بوبكر أستاذ محاضر-أ- بجامعة ورقلة وذلك لتقييم مطبوعة الدروس الخاصة بالأستاذ رواجي رياض أستاذ محاضر "أ" بقسم الهندسة الكهربائية لجامعة المسيلة تحت عنوان :

" TP Mesures électriques et électroniques "

مطبوعة دروس مكتوبة باللغة الإنجليزية تحت عنوان:

" Practical work : Electrical and Electronic Measurements "

وبعد إطلاع رئيس اللجنة العلمية ورئيس القسم على التقارير الواردة و التي كانت كلها ايجابية، وعليه فإن اللجنة لا ترى مانعا أن تتخذة سندا في تدريس طلبة السنة الثانية ليسانس في الكهروتقني ، شعبة الكهروتقني ، ميدان علوم و تكنولوجيا و أن تعتمد في أي تقييم للمسار العلمي للأستاذ المعني.

رئيس القسم

رئيس اللجنة العلمية

أ.د بوقرة عبد الرحمان



ذفاف المبروك



Semestre: 4

Unité d'enseignement: UEM 2.2

Matière 1: TP Mesures électriques et électroniques

VHS: 15h00 (TP: 1h00)

Crédits: 1

Coefficient: 1

Objectifs de l'enseignement:

Initier l'étudiant aux techniques de mesure des grandeurs électriques et électroniques. Le familiariser à l'utilisation des appareils de mesures analogiques et numériques.

Connaissances préalables recommandées:

- Electricité Générale
- Lois fondamentales de la physique

Contenu de la matière:

Travaux Pratiques:

TP N° 1 : Mesure de résistance:

Effectuer la mesure des résistances par les 5 méthodes suivantes : voltampère métrique, ohmmètre, pont de Wheatstone, comparaison et substitution.

Comparer ces méthodes entre elles et établir un calcul d'erreurs.

TP N° 2 : Mesure d'inductance :

Effectuer la mesure des inductances par les 3 méthodes suivantes : voltampère métrique, pont de Maxwell, résonance.

Comparer ces méthodes entre elles et établir un calcul d'erreurs.

TP N° 3 : Mesure de capacité :

Effectuer la mesure des capacités par les 3 méthodes suivantes : voltampère métrique, pont de Sauty, résonance.

Comparer ces méthodes entre elles et établir un calcul d'erreurs.

TP N° 4 : Mesure déphasage :

Effectuer la mesure des résistances par les 2 méthodes suivantes : Phasemètre et oscilloscope.

TP N° 5 : Mesure de puissance en monophasé :

Effectuer la mesure des résistances par les 5 méthodes suivantes : wattmètre, Cos ϕ mètre, trois voltmètres, trois ampèremètres, capteur de puissance.

Comparer ces méthodes entre elles et établir un calcul d'erreurs.

TP N° 6 : Mesure de puissance en triphasé :

Effectuer la mesure des résistances par les méthodes suivantes : Système étoile et système triangle, équilibrés et déséquilibrés.

Mode d'évaluation:

Contrôle continu : 100 %.

Références bibliographiques:

(Livres et photocopiés, sites internet, etc.)

- 1- M. Cerr ; Instrumentation industrielle : T.1 ; Edition Tec et Doc.
- 2- M. Cerr ; Instrumentation industrielle : T.2 ; Edition Tec et Doc.
- 3- P. Oguic ; Mesures et PC ; Edition ETSF.
- 4- D. Hong ; Circuits et mesures électriques ; Dunod ; 2009.
- 5- W. Bolton ; Electrical and electronic measurement and testing ; 1992.
- 6- A. Fabre ; Mesures électriques et électroniques ; OPU ; 1996.
- 7- G. Asch ; Les capteurs en instrumentation industrielle ; édition DUNOD, 2010.

- 8- L. Thompson ; Electrical measurements and calibration: Fundamentals and applications, Instrument Society of America, 1994.
- 9- J. P. Bentley ; Principles of measurement systems ; Pearson education ; 2005.
- 10- J. Niard ; Mesures électriques ; Nathan ; 1981.
- 11- P. Beauvilain ; Mesures Electriques et Electroniques.

Source Internet

- <http://sitelec.free.fr/cours2htm>
- <http://perso.orange.fr/xcotton/electron/coursetdocs.ht>
- <http://economie.u-bourgogne.fr/elearning/physique.html>
- <http://www.technique-ingenieur.fr/dossier/appareilsdemesure>

People's Democratic Republic of Algeria Ministry of Higher Education and Scientific
Research

Mohamed Boudiaf University at M'Sila



Faculty of Technology

Department of Electrical Engineering

Practical work handout

Subject: Electrical and Electronic Measurements

Speciality: Electrotechnics.

Level: 2nd year bachelor's degree

Author: Riyadh ROUABHI

Academic Year: 2024-2025

Author

Dr: ROUABHI Riyadh
riyadh.rouabhi@univ-msila.dz

Faculty/Institute: Faculty of Technology
Department: Electrical Engineering
Institution: Mohamed BOUDIAF University of M'sila - Algeria

Subject title: **Electrical and Electronic Measurements**

Semester: 04
Fundamental Teaching Unit Code: UEM 2.2
Number of teaching hours of practical work 09.00 h
Number of hours of personal work for the student: 1.5 h
Number of credits: 1; Subject coefficients: 1

Foreword

With a view to applying the new university syllabuses proposed by the national educational councils as part of the overhaul of the curricula initiated by the Ministry of Higher Education and Scientific Research, this book has been written mainly as a teaching tool with the aim of facilitating and providing students in the 2nd year of a degree in Electrotechnics with the basic principles of electrical and electronic Measurements.

PW n°01: Resistance measurement

Aim

- ✓ Measure the unknown resistances using the following methods: Colour Code; Ohm Meter; Volt-Amperometric.
- ✓ Evaluate the absolute and relative accuracy of each method.

Equipment used

- Power Sources (DC).
- Resistors.
- Instruments (voltmeters, milliammeter, microammeter, multimeters).

PW n°02: Inductance measurement

Aim

- ✓ Measure an inductance using the volt-amperometric and series RLC methods.
- ✓ Measure Quality factor.

Equipment used

- Power Sources (DC).
- The Oscilloscope
- Function Generator (GBF)
- Electrical loads (resistors, inductors and capacitors).
- Measuring instruments (multimeters, ammeters, milliammeters, voltmeters).

PW n°03: Capacity measurement

Aim

- ✓ Measure the capacitance of two capacitors using the volt-Amperometric method from the 'downstream' and 'upstream' assemblies.
- ✓ Evaluate the absolute and relative accuracy of the two assemblies.

Equipment used

- Voltage sources (AC).
- Capacitors load.
- Instruments (voltmeters, ammeters, multimeters).

PW n°04: Phase shift measurement

Aim

- ✓ Learn to use an oscilloscope: setting, starting, displaying and measuring alternating signals (amplitude, frequency and phase shift).
- ✓ Learn to use a basic frequency generator (GBF).

Equipment used

- Basic frequency generator (GBF).
- Oscilloscope
- Measuring instruments (multimeters, Phasemeter) .
- Electrical loads (resistors and capacitors).

PW n°01: Resistance measurement

I	Aim of the manipulation	01
II	Equipment used	01
III	Evaluation method	01
IV	Theoretical reminder	01
V	Method n°01: Direct measurements using Color Code Designation	01
VI	Method n°02: Direct measurements using the ohmmeter	02
VII	Method n°03 : Indirect measurements using the Volt-Amperometric method	03
VII.1	Selecting the appropriate circuit	03
VII.2	Measurement Table	03
VII.3	Remarks.....	03
VIII	Conclusion	04

PW n°02: Inductance measurement

I	Aim of the manipulation	01
II	Equipment used	01
III	Evaluation method	01
IV	Theoretical reminder	01
V	Method n°01: Indirect measurements using the Volt-Amperometric method	01
V.1	Volt-Amperometric method with DC source.....	01
V.2	Volt-Amperometric method with AC source.....	02
VI	Method n°02: Indirect measurements using the Resonance of a series RLC circuit	03
VI.1	The Resonance of a series RLC circuit	03
VI.2	Interpretation of results	05
VII	Conclusion	05

PW n°03: Capacity measurement

I	Aim of the manipulation	01
II	Equipment used	01
III	Evaluation method	01
IV	Theoretical reminder	01
V	Method n°01: Indirect measurements using the Volt-Amperometric method	01
V.1	Calculation error.....	02
V.2	Volt-Amperometric method with downstream assembly	03
V.3	Volt-Amperometric method with Upstream assembly	03
V.4	Measurement Table	03
V.5	Interpretation of results	05
VI	Conclusion	05

PW n°04: Phase shift measurement

I	Aim of the manipulation	01
II	Equipment used	01
III	Evaluation method	01
IV	Theoretical reminder	01
IV.1	How to use an oscilloscope (Basic Approach).....	01
IV.2	Voltage measurement	02
IV.3	Frequency measurement	02
IV.4	Phase shift measurement	03
V	Practical part	03
V.2	Voltage measurement	03
V.3	Frequency measurement	04
V.4	Phase shift measurement	04
V.5	Interpretation of results	05
VI	Conclusion	05

جامعة محمد بوضياف - المسيلة -
Mohamed Boudiaf University at M'sila
كلية التكنولوجيا
Faculty of Technology
قسم الهندسة الكهربائية و قسم الإلكترونيك
Department of Electrical Engineering and Department of Electronics

University year: 2024/2025

2nd year Electrical Engineering and Electronics

Applied Work in Electrical and Electronic Measurements

السنة الجامعية: 2024/ 2025

السنة الثانية هندسة كهربائية و إلكترونيك

أعمال تطبيقية في القياسات الكهربائية والإلكترونية

PW n°01 : Resistance measurement

Duration : 1^h30.

Date of the experiment: / /

Report prepared by:

Last Name	First Name	Group	S/Group	Final Note
-	-	-	-	-
-	-	-	-	-
-	-	-	-	-
-	-	-	-	-

Instructions :

- Internal laboratory regulations must be observed.
- You must wear a lab coat.
- Attendance is compulsory and will be monitored. Any unjustified absence or failure to hand in a report will result in a mark of 0/20.
- Have your assemblies checked before connecting the voltage source.
- It is strictly forbidden to move equipment from one station to another. In the event of a breakdown or faulty equipment, contact the teacher.
- The report must be written by a maximum of four students.
- The report must be handed in at the beginning of the next session.
- The report must include the following sections:
 - TP cover page.
 - The date of the practical session.
 - Last Name and first name of the main writer.
 - Last Names and first names of the WP participants.
 - Preparation and work in manuscript.

I. Aim of the manipulation

- ✓ Measure the unknown resistances using the following methods: Colour Code; Ohm Meter; Volt-Amperometric.
- ✓ Evaluate the absolute and relative accuracy of each method.

II. Equipment used

- Power Sources (DC).
- Resistors.
- Instruments (voltmeters, miliammeter, microammeter, multimeters).

III. Evaluation method

Continuous assessment: 100%.

IV. Theoretical reminder

A resistor is an electronic or electrical component whose primary characteristic is to resist the flow of electric current, measured in ohms. Electrical resistance is a fundamental part of electricity. The term "resistance" primarily refers to a physical property, but it has also come to refer to a specific type of component. Some people prefer to call it a "resistive device".

V. Method n°01: Direct measurements using Color Code Designation

To determine the ohmic value of a resistor, it is necessary to identify the colour bands present on the resistor (see Figure 1) and associate them with the universal colour code. The international standard IEC 60757, entitled "Colour Code Designation" (1983), defines a colour code to be applied to resistors to indicate their resistance values.

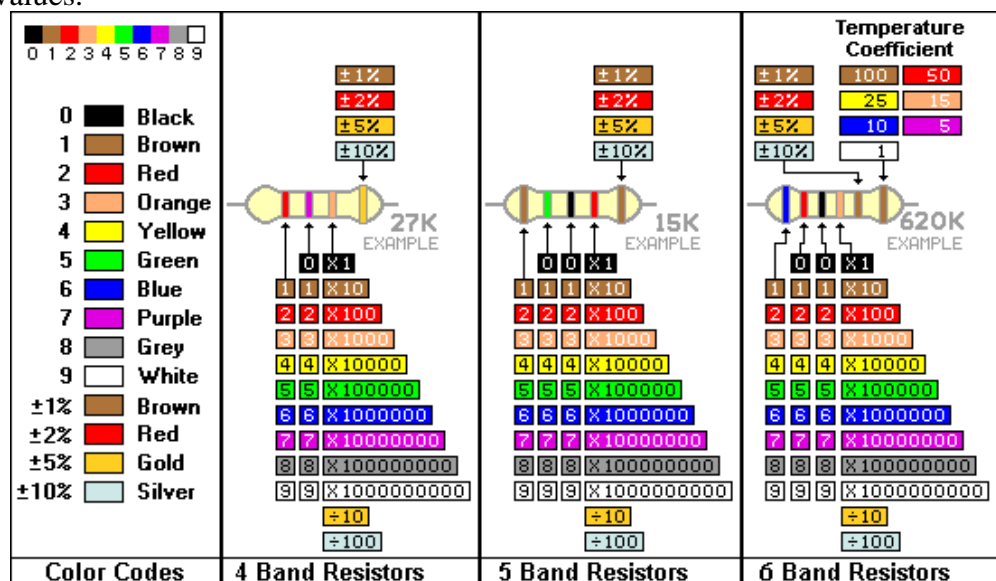

Figure 1: Resistor Color Code

PW n°01: Resistance measurement



R₁=



R₂=

VI. Method n°02 : Direct measurements using the ohmmeter

Measure the values of resistors **R₁**, and **R₂** using the multimeter in ohmmeter mode, then calculate the relative ∂R and absolute ΔR uncertainties using the following relationship:

$$\Delta R = R * \textit{precision} + \textit{number of digits} * \textit{resolution}$$

Instructions for recording the accuracy of the measurements provided according to the range used are given in the uncertainty table below:

<i>Range</i>	<i>Precision +Number of digits</i>	<i>Resolution</i>	<i>Uncertainty</i>
200Ω	±(1%+3 digits) 0,1Ω	0,1Ω	4,5Ω
2kΩ	(0,8%+1digits)	1Ω	30Ω
20kΩ	±(0 ,8%+1 digits)	10Ω	300Ω
200kΩ	±(0,8%+1digits)	100Ω	3kΩ
2MΩ	±(0.8%+1 digits)	1kΩ	42kΩ
20MΩ	±(2%+2 digits)	10kΩ	620kΩ

Table 1

Measure the resistances, then calculate the measurement uncertainty and complete the following table

	Measurement of R ₁ =220Ω	Measurement of R ₂ =220KΩ
Range		
R		
ΔR		
∂R= ΔR/R		

Table 2

VII. Method n°03 : Indirect measurements using the Volt-Amperometric method

1) Selecting the appropriate circuit

This involves selecting the appropriate circuit, upstream or downstream, for measuring each of the resistors R_1 and R_2 resistors, specifying the measuring equipment. Then, once the measurements have been made, determine the value of each resistor and its uncertainty for the selected circuit.

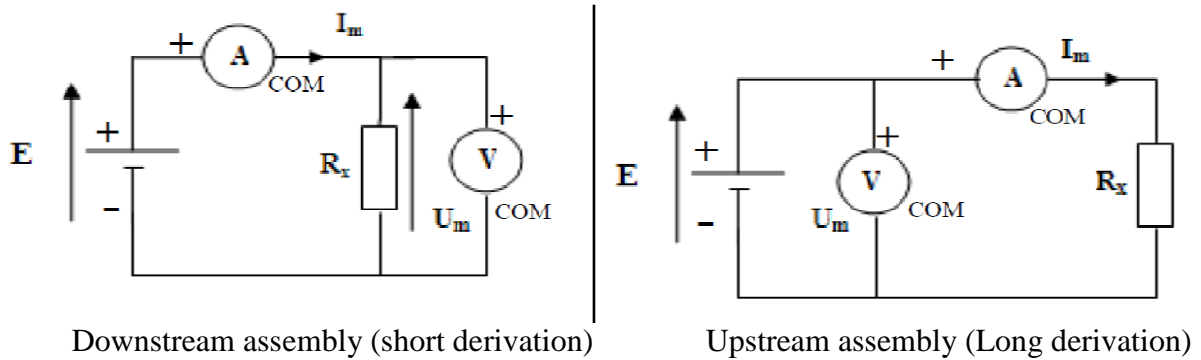

Figure 2

The choice of the assembly is made according to the following rule:

If $R \leq \sqrt{R_A * R_V}$ (low value resistances), we prefer the short assembly;

If $R \geq \sqrt{R_A * R_V}$ (high value resistances), we prefer the long assembly;

2) Measurement Table

E=5V,

Miliammeter Class =.....

Microammeter Class =.....

Voltmeter Class =.....

3) Remarks

✚ **Absolute uncertainty ΔX :** Calculation of the absolute uncertainty ΔX due to a measuring device

$$\Delta X = \frac{\text{Class} * \text{Rang}}{100}$$

✚ **Relative uncertainty:** $\partial X = \Delta X / X$ generally expressed as a percentage (%).

$$\text{✚ } \Delta R / R = \Delta I / I + \Delta V / V$$

PW n°01: Resistance measurement

- Measure the current and voltage for the two resistors R_1 , R_2 .
- Record the measured and calculated results in the table below:

	$R_1=220\Omega$	$R_1=220\Omega$	$R_2=220K\Omega$	$R_2=220K\Omega$
Assembly adopted	Downstream	Upstream	Downstream	Upstream
Range for I (C_A)				
Scale for I (E_A)				
Current reading (L_A)				
$I_m=(L_A *C_A/E_A)$				
Range for V(C_V)				
Scale for V (E_V)				
Voltage reading (L_V)				
$U_m= (L_V *C_V/E_V)$				
$R_m=U_m/I_m$				
ΔR_m				

Table 3

Interpretation of results

.....

.....

.....

VIII. Conclusion

.....

.....

.....

.....

جامعة محمد بوضياف - المسيلة -
Mohamed Boudiaf University at M'sila
كلية التكنولوجيا
Faculty of Technology
قسم الهندسة الكهربائية و قسم الإلكترونيك
Department of Electrical Engineering and Department of Electronics

University year: 2024/2025

2nd year Electrical Engineering and Electronics

Applied Work in Electrical and Electronic Measurements

السنة الجامعية: 2024/ 2025

السنة الثانية هندسة كهربائية و إلكترونيك

أعمال تطبيقية في القياسات الكهربائية والإلكترونية

PW n°02: Inductance measurement

Duration: 1^h30.

Date of the experiment: / /

Report prepared by:

Last Name	First Name	Group	S/Group	Final Note
-	-	-	-	-
-	-	-	-	-
-	-	-	-	-
-	-	-	-	-

Instructions :

- Internal laboratory regulations must be observed.
- You must wear a lab coat.
- Attendance is compulsory and will be monitored. Any unjustified absence or failure to hand in a report will result in a mark of 0/20.
- Have your assemblies checked before connecting the voltage source.
- It is strictly forbidden to move equipment from one station to another. In the event of a breakdown or faulty equipment, contact the teacher.
- The report must be written by a maximum of four students.
- The report must be handed in at the beginning of the next session.
- The report must include the following sections:
 - TP cover page.
 - The date of the practical session.
 - Last Name and first name of the main writer.
 - Last Names and first names of the WP participants.
 - Preparation and work in manuscript.

I. Aim of the manipulation

- ✓ Measure an inductance using the volt-amperometric and series RLC methods.
- ✓ Measure Quality factor

II. Equipment used

- Power Sources (DC).
- The Oscilloscope
- Function Generator (GBF)
- Electrical loads (resistors, inductors and capacitors).
- Measuring instruments (multimeters, ammeters, milliammeters, voltmeters).

III. Evaluation method

Continuous assessment: 100%.

IV. Theoretical reminder:

A coil consists of a winding of conductive turns around an insulator. It therefore has a certain internal resistance due to the long length of wire. The coil is therefore symbolised in the receiver convention as follows:

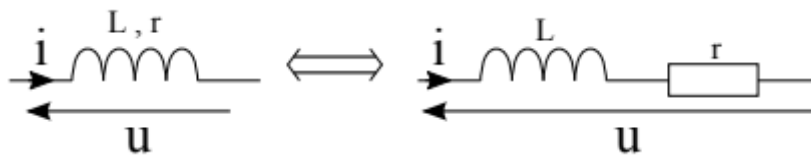

Figure 1: Symbolisation of a real coil, receiver convention

V. Method n°01: Indirect measurements using the Volt-Amperometric method

1) Volt-Amperometric method with DC source

- Carry out the following assembly.

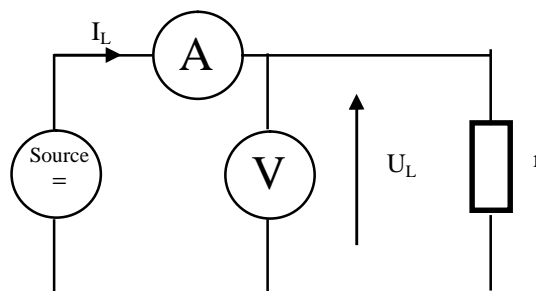

Figure 2: Volt-Amperometric method with DC source

PW n°02: Inductance measurement

- Find U_L and I_L by varying U from 1V to 9V.

U(V)	1	3	5	7	9
U_L(V)					
I_L(A)					
$Z = r = U_L / I_L$					
r_{moy}					

Table 1

2) Volt-Amperometric method with AC source

- The coil is fed by a sinusoidal generator $U(t)$ with an effective value $U(t) = 7V$ and a variable frequency.
- Carry out the installation by positioning the equipment so that $U_L(V)$, I_L

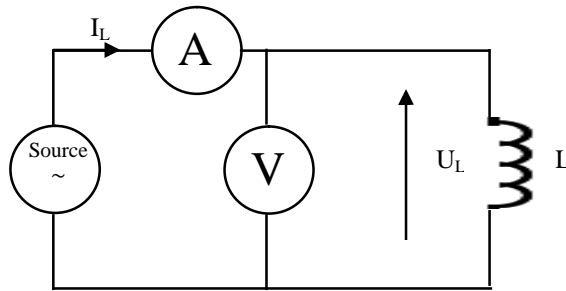

Figure 3: Volt-Amperometric method with AC source

- Find $U_L(V)$, I_L by varying the frequency from 100 Hz to 250 Hz
- Calculate the value of Z from these measurements,
- Derive L

f(Hz)	100	150	200	250
U_L(V)				
I_L(A)				
$Z = U_L / I_L$				
L (mH)				

Table 2

VI. Method n°02: Indirect measurements using the Resonance of a series RLC circuit.

1) The Resonance of a series RLC circuit

To study the resonance of the RLC circuit, we will make the following series circuit:

- An inductor set at **150 mH**
- A capacitor set at **3.3 μF**
- A resistor set at **560 Ω**.

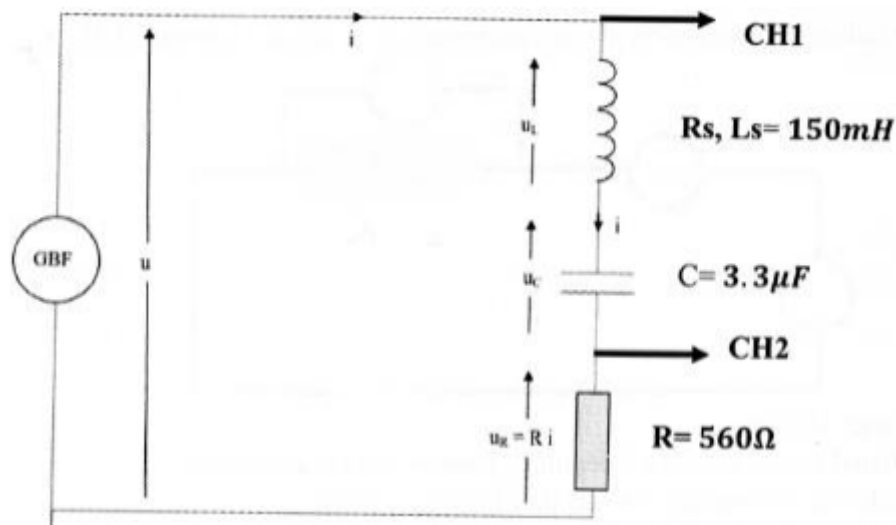
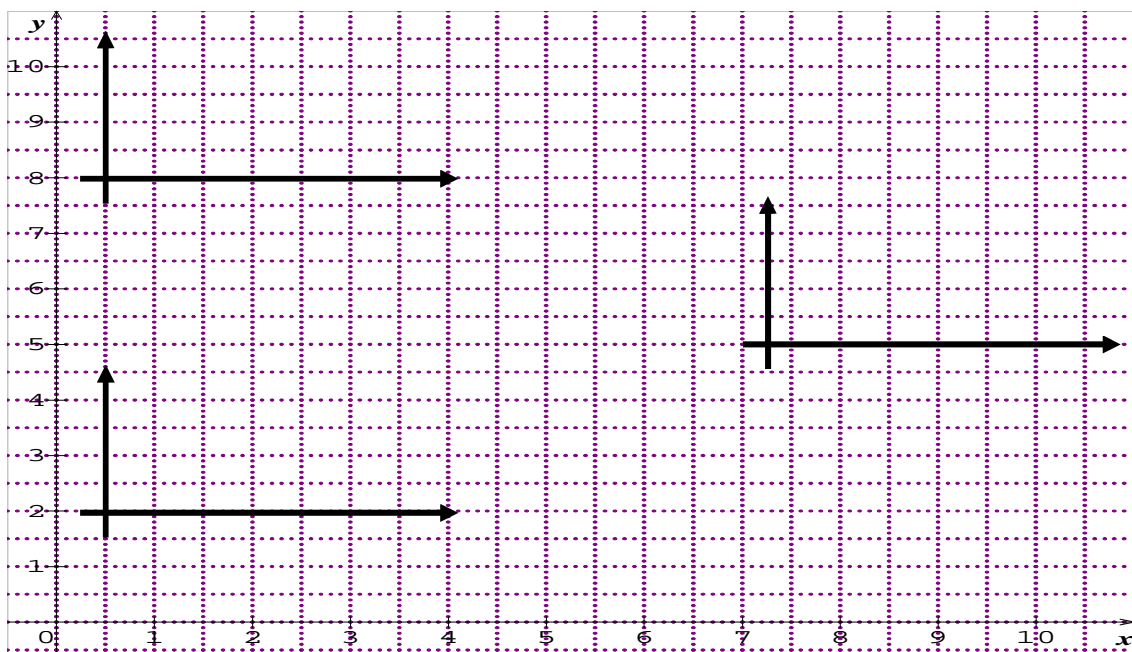

Figure 4: RLC circuit

- Look at the current and voltage curves on the oscilloscope.
- Plot these curves on a millimetre sheet for $f=100$; $f=225$; $f=500$.



PW n°02: Inductance measurement

- Calculate the phase shift $\varphi_{\text{experimental}}$ directly on the oscilloscope and compare it with the theoretical value.

.....

.....

.....

In general the impedance Z of a dipole is given by the relationship: $Z = U_{\text{max}} / I_{\text{max}} = U_{\text{eff}} / I_{\text{eff}} = U / I$ through the dipole.

- Record the amplitude of the voltage across the resistor U_R , the capacitor U_C and the coil U_L and the current I for frequencies between **100 Hz** and **500 Hz**.
- Plot the curves $I, U_C, U_L, U_R = G(f)$

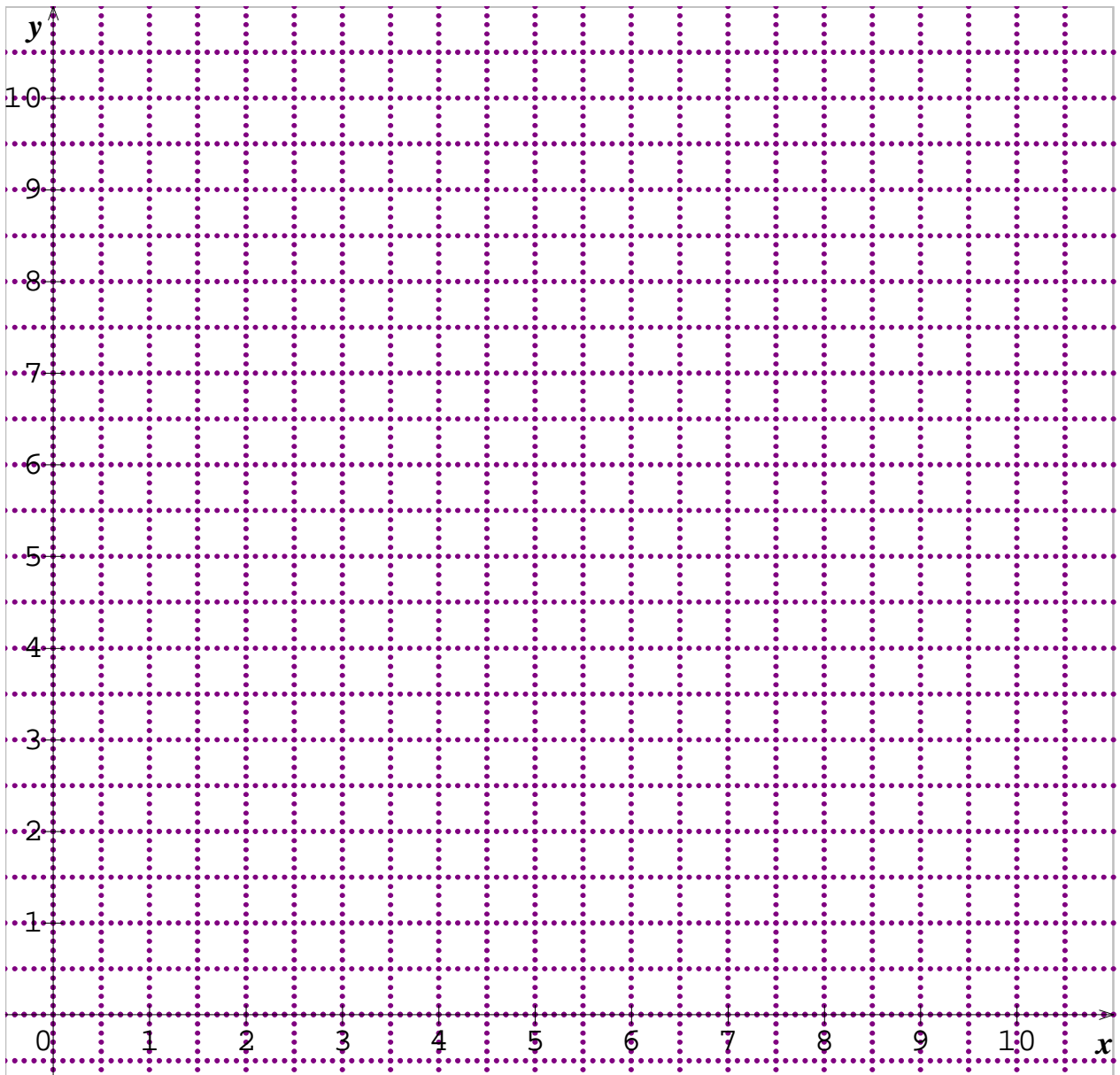

PW n°02: Inductance measurement

- Calculate the resonance frequency
.....
- Calculate the bandwidth and the quality factor, given that $Q = f_0/\Delta f$
.....
.....
- Deduce the value of L for all frequencies;

f(Hz)	100	200	f_0	250	500
I (A)					
$U_R(V)$					
$U_C(V)$					
$U_L(V)$					
$Z = U / I$					
$R = U_R / I$					
$Z_C = U_C / I$					
$Z_L = U_L / I$					
L (mH)					

Table 3

- Discuss each of the results obtained.
.....
.....
.....

VII. Conclusion

.....

University year: 2024/2025

2nd year Electrical Engineering and Electronics

Applied Work in Electrical and Electronic Measurements

السنة الجامعية: 2024/ 2025

السنة الثانية هندسة كهربائية و إلكترونيك

أعمال تطبيقية في القياسات الكهربائية والإلكترونية

PW n°03: Capacity measurement

Duration : 1^h30.

Date of the experiment: / /

Report prepared by:

Last Name	First Name	Group	S/Group	Final Note
-	-	-	-	-
-	-	-	-	-
-	-	-	-	-
-	-	-	-	-

Instructions :

- Internal laboratory regulations must be observed.
- You must wear a lab coat.
- Attendance is compulsory and will be monitored. Any unjustified absence or failure to hand in a report will result in a mark of 0/20.
- Have your assemblies checked before connecting the voltage source.
- It is strictly forbidden to move equipment from one station to another. In the event of a breakdown or faulty equipment, contact the teacher.
- The report must be written by a maximum of four students.
- The report must be handed in at the beginning of the next session.
- The report must include the following sections:
 - TP cover page.
 - The date of the practical session.
 - Last Name and first name of the main writer.
 - Last Names and first names of the WP participants.
 - Preparation and work in manuscript.

I. Aim of the manipulation

- ✓ Measure the capacitance of two capacitors using the volt-Amperometric method from the 'downstream' and 'upstream' assemblies.
- ✓ Evaluate the absolute and relative accuracy of the two assemblies.

II. Equipment used

- Voltage sources (AC).
- Capacitors load.
- Instruments (voltmeters, ammeters, multimeters).

III. Evaluation method

Continuous assessment: 100%.

IV. Theoretical reminder:

A capacitor consists of two conductive plates separated by an insulator called a dielectric. They can be flat, cylindrical or spherical. Capacitors are characterised by their capacitance C , expressed in farads. This is their ability to store charges when subjected to a given potential difference.

The armature receiving the current carries the charge $+q$, the other armature carries the charge $-q$. The capacitor is symbolised as follows:

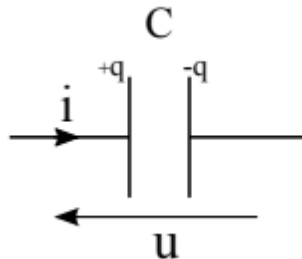

Figure 1: Symbolisation of a capacitor, receiver convention

V. Method n°01: Indirect measurements using the Volt-Amperometric method

The volta-amperometric method is only used to measure capacitances $C > 0.1 \mu\text{F}$.

Errors are minimised if the upstream and downstream assemblies are used as follows:

- Upstream : $C \leq 10 \mu\text{F}$
- Downstream: $C \geq 10 \mu\text{F}$

The impedance Z is written as:
$$Z = R + \frac{1}{j\omega C}$$

Where R is the parasitic resistance introduced by the capacitance C and per row of connections.

But we can neglect R and consider only the circuit that is capacitive, so: $Z_C \approx X_C = \frac{U_C}{I}$

PW n°03: Capacity measurement

Hence:

$$C = \frac{1}{W X_c} = \frac{1}{2\pi f U c}$$

However, the exact capacitance values can be calculated for each circuit, taking into account the systematic error.

Thus, in the case of the upstream circuit, the voltmeter measures a voltage $U = U_a + U_c$

Therefore:

Upstream:	(A)	$C_{cala} = \frac{1}{2\pi f \sqrt{\frac{U^2}{I^2} + R_a^2}}$	$C_{mes} = \frac{I}{2\pi f U}$
Downstream:	(B)	$C_{cala} = \frac{\sqrt{I^2 - I_v^2}}{2\pi f U} = \frac{\sqrt{I^2 - \frac{U^2}{R_v^2}}}{2\pi f U}$	

Demonstrate mathematically equations (A) and (B)

.....

.....

.....

.....

.....

1) Calculation error

The total relative error is:

$$\frac{\Delta C_{mes}}{C_{mes}} \approx \frac{\Delta U_{mes}}{U_{mes}} + \frac{\Delta I_{mes}}{I_{mes}} + \frac{\Delta f_{mes}}{f_{mes}} \quad [\%]$$

We give: $\frac{\Delta f_{mes}}{f_{mes}} = 0.5\%$

With $f = 50\text{Hz}$, $C_{probable} \approx \Delta C_{mes} \pm \frac{\Delta C_{mes}}{C_{mes}} [F]$.

$$\Delta V = \frac{\text{Voltmeter class} * \text{Voltmeter range}}{100}$$

$$\Delta I = \frac{\text{Ammeter class} * \text{Ammeter range}}{100}$$

2) Volt-Amperometric method with downstream assembly

Before starting to work on the autotransformer, a number of precautions must be taken. Firstly, the autotransformer (Source AC) must only be connected to its minimum value, i.e. zero. Set the voltmeter and ammeter to the maximum range.

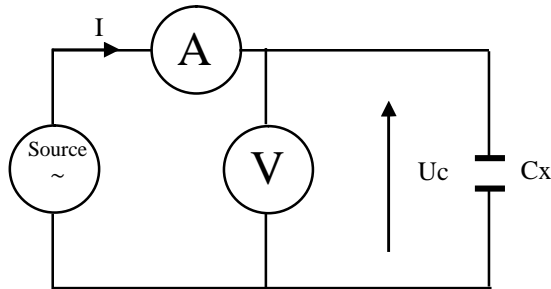

Figure 2: Volt-Amperometric method with downstream assembly

3) Volt-Amperometric method with Upstream assembly

For handling, the calibres should be selected accordingly, but all operations must be carried out with the unit de-energised, i.e. with the autotransformer (Source AC) disconnected.

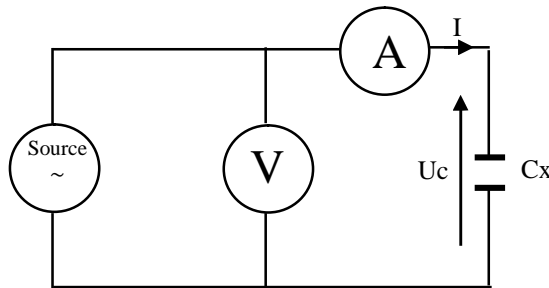

Figure 3: Volt-Amperometric method with Upstream assembly

Set the autotransformer (Source AC) slider to the position corresponding to **70 volts**, the value indicated by the voltmeter. This value remains constant for all measurements.

4) Measurement Table

Miliammeter Class =.....

Voltmeter Class =.....

PW n°03: Capacity measurement

✚ Measure the current for the two capacitors **C₁**, **C₂**.

✚ Record the measured and calculated results in the table below:

	C₁=4μF	C₁= 4μF	C₂= 11μF	C₂= 11μF
Assembly adopted	Downstream	Upstream	Downstream	Upstream
Range for I (C _A)				
Scale for I (E _A)				
Current reading (L _A)				
Im=(L_A *C_A/E_A)				
Range for V(C _V)				
Scale for V (E _V)				
Voltage reading (L _V)				
Um=(L_V *C_V/E_V)				
Xc				
Ra				
Rv				
Cmes[F]				
ΔCmes[%]				
Ccalc[F]				
δCmes = (ΔCmes/Cmes) [%]				
Cprobable [F]				

Table 3

5) Interpretation of results

.....
.....
.....
.....
.....

VI. Conclusion

.....
.....
.....
.....
.....
.....
.....
.....
.....
.....
.....

جامعة محمد بوضياف - المسيلة -
Mohamed Boudiaf University at M'sila
كلية التكنولوجيا
Faculty of Technology
قسم الهندسة الكهربائية و قسم الإلكترونيك
Department of Electrical Engineering and Department of Electronics

University year: 2024/2025

2nd year Electrical Engineering and Electronics

Applied Work in Electrical and Electronic Measurements

السنة الجامعية: 2024/ 2025

السنة الثانية هندسة كهربائية و إلكترونيك

أعمال تطبيقية في القياسات الكهربائية والإلكترونية

PW n°04: Phase shift measurement

Duration : 1^h30.

Date of the experiment: / /

Report prepared by:

Last Name	First Name	Group	S/Group	Final Note
-	-	-	-	-
-	-	-	-	-
-	-	-	-	-
-	-	-	-	-

Instructions :

- Internal laboratory regulations must be observed.
- You must wear a lab coat.
- Attendance is compulsory and will be monitored. Any unjustified absence or failure to hand in a report will result in a mark of 0/20.
- Have your assemblies checked before connecting the voltage source.
- It is strictly forbidden to move equipment from one station to another. In the event of a breakdown or faulty equipment, contact the teacher.
- The report must be written by a maximum of four students.
- The report must be handed in at the beginning of the next session.
- The report must include the following sections:
 - TP cover page.
 - The date of the practical session.
 - Last Name and first name of the main writer.
 - Last Names and first names of the WP participants.
 - Preparation and work in manuscript.

I. Aim of the manipulation

- ✓ Learn to use an oscilloscope: setting, starting, displaying and measuring alternating signals (amplitude, frequency and phase shift).
- ✓ Learn to use a basic frequency generator (GBF).

II. Equipment used

- Basic frequency generator (GBF).
- Oscilloscope.
- Measuring instruments (multimeters, Phasemeter).
- Electrical loads (resistors and capacitors).

III. Evaluation method

Continuous assessment: 100%.

IV. Theoretical reminder:

The oscilloscope is a measuring instrument that can be used to display and analyse electrical signals as a function of time, or variations in one voltage as a function of another. The oscilloscope accepts two input channels, allowing you to view two separate electrical signals on the same screen (so you can compare frequencies, amplitudes and phase shifts).

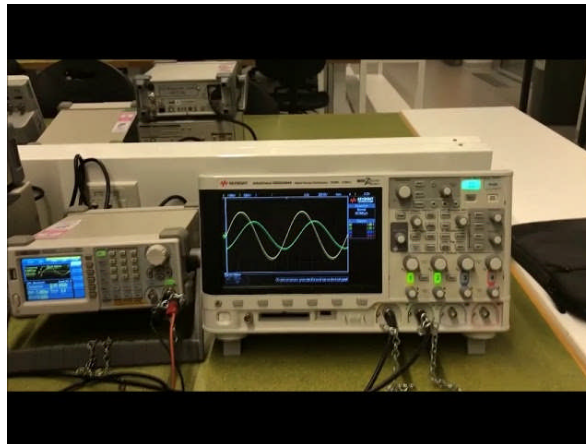

Figure 1: Picture of the oscilloscope connected to GBF

1) How to use an oscilloscope (Basic Approach)

- Connection: Connect the probe to a channel and earth to the circuit.
- Time base setting: Adjust to see a few periods of the signal.
- Volt/Div setting: Adjust so that the signal occupies part of the screen.
- Trigger: Set to a rising or falling edge to stabilise the display.
- Measurement: Use the cursors or automatic functions.

2) Voltage measurement

To measure a voltage (V) with an oscilloscope, you must choose a calibre such that - the amplitude of the peak-to-peak signal occupies most of the height of the screen; this allows the signal to be displayed without overshoot, thus minimising reading errors.

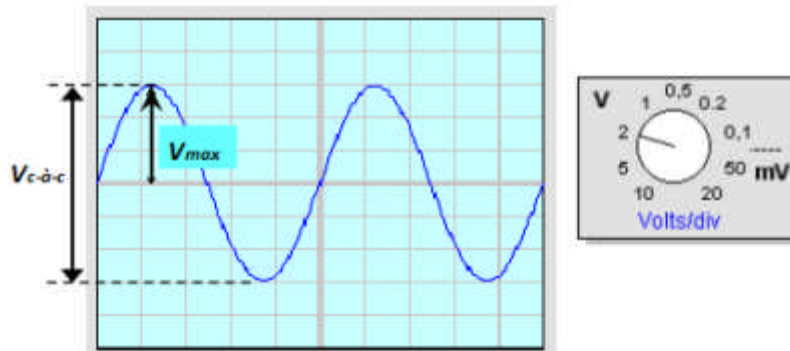

Figure 2: Measure a voltage (V) with an oscilloscope

We have: $V_{p-t-p} = \text{Number of cm. Range}$

$$V_{\max} = V_{p-t-p} / 2$$

$$V_{\text{rms}} = V_{\max} / 2$$

The effective value V_{rms} is the value indicated by the multimeter when used to measure an alternating voltage.

3) Frequency measurement

To measure the frequency of a signal on an oscilloscope, you must select a time base position where the signal period occupies most of its length. This minimises reading errors.

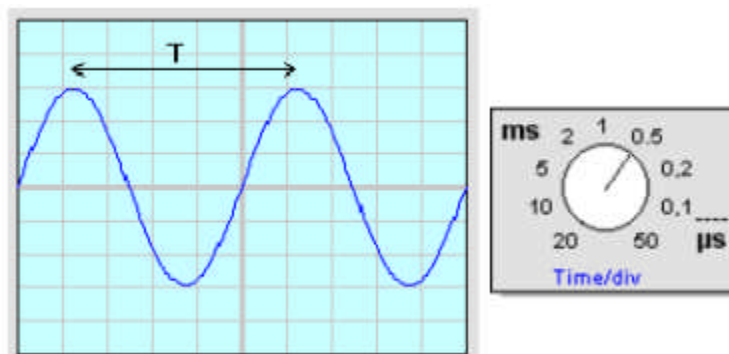

Figure 3: Measure a frequency (Hz) with an oscilloscope

We have: $T = \text{Number of cm. Range}$

$$f = 1 / T$$

4) Phase shift measurement

To measure the offset between two signals, they need to be observed simultaneously. To do this, you need to take the two voltages relative to a common point, which is earth. We then use the direct method, which is applicable when the two signals have the same frequency. Consider two periodic signals, one of which is out of phase with the other (lagging or leading), as shown in Figure 4:

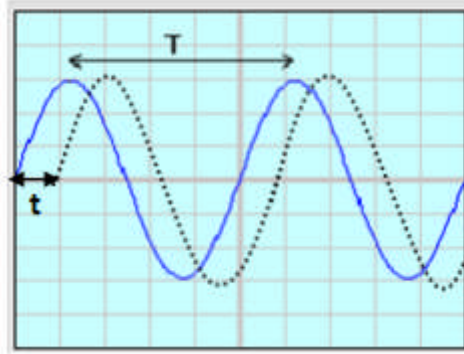

Figure 4: Measure a Phase shift with an oscilloscope

To calculate the phase shift φ (in degrees) we have: $\varphi = t / T \times 360^\circ$

With: **T**: Period of the signal.
t: Offset between the two signals.

V. Practical part

1) Voltage measurement

Using a function generator (GBF), apply a sinusoidal voltage to the input of channel I of the oscilloscope and select the correct rating to display the signal correctly.

- Measure the RMS voltage from the amplitude displayed on the oscilloscope screen.
- Use a multimeter to measure the voltage.
- Record these values in Table 1 and do the same for a triangle and square wave signal.



			
Range . Oscillo (V/cm)			
Nber of cm (p-t-p)			
$V_{p-t-p}(V)$			
V_{max}			
V_{rms}			
V_{mult}			

Table 1

Interpretation of results

.....

.....

.....

2) Frequency measurement

Using a GBF, apply a sinusoidal signal with a frequency of more than 100 Hz to the input of channel I, then select the calibers that allow the signal to be displayed correctly.

- Measure the period of this signal and enter these values in Table 2.
- Do the same for a triangular signal and a square wave signal.



			
Freq. GBF(Hz)			
Range . B.Temps (ms/cm)			
Nber of cm (for T)			
T(s)			
f= 1/T (Hz)			

Table 2

Interpretation of results

.....

.....

.....

3) Phase shift measurement

- Carry out the following assembly:

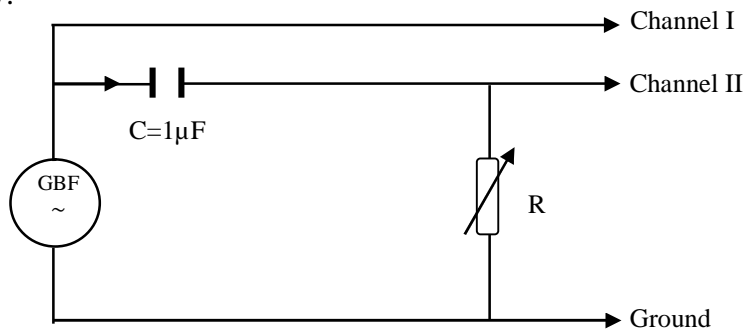

Figure 4: Phase shift measurement method

PW n°04: Phase shift measurement

- Check that the GD buttons are pressed (input signal is grounded), then align the two oscilloscope traces so that they are perfectly superimposed on the x-axis.
- Vary the resistance R and determine the phase shift for each value of R.
- Record these values in Table 3.

R (KΩ)	1	2	4	8	10
t (ms)					
T (ms)					
$\varphi = t / T \times 360^\circ$					
φ with Phasemeter					

Table 3

Interpretation of results

.....
.....
.....

VI. Conclusion

.....
.....
.....
.....
.....
.....
.....
.....
.....

Practical work handout

Subject: Electrical and Electronic Measurements

Speciality: Electrotechnics.

Level: 2nd year bachelor's degree

Author: Riyadh ROUABHI

riyadh.rouabhi@univ-msila.dz

Abstract –

This practical workbook (PW Electrical and Electronic Measurements) is intended for students in the second year of their bachelor's degree (Electrotechnics) at the Mohamed Boudiaf University in M'sila, Algeria. Its aim is to provide them with a working document that will enable them to validate the concepts taught in the lectures and tutorials on electrical and electronic measurements and to facilitate their practical application in experimental manipulations. It will also enable them to acquire the necessary know-how to use the equipment and the different measuring instruments used correctly and to gain a good understanding of the methods used. For this reason, the preparation of the practical work must be taken seriously and be the subject of particular attention on the part of the students, in order to obtain the maximum benefit from it without damaging the equipment placed at their disposal. All the sections presented in this document were carried out at the Bidaghogic Electronics Laboratory of the Mohamed Boudiaf University in M'sila.

Keywords – Resistance measurement, Inductance measurement, Capacity measurement, Phase shift measurement.