

الجمهورية الجزائرية الديمقراطية الشعبية  
The People's Democratic Republic of Algeria  
وزارة التعليم العالي والبحث العلمي  
Ministry of Higher Education and Scientific Research  
جامعة محمد بوضياف المسيلة  
Mohamed Boudiaf University-M'Sila

FACULTY OF TECHNOLOGY

DEPARTMENT OF CIVIL  
ENGINEERING

N:...../...../2024



Domaine : Sciences Technologique

Field: Civil Engineering

Option: Structures

Thesis submitted for the academic Master's degree

By: BENSENOUSSI Sounia

Title

# Comparative Analysis of Seismic Retrofit Techniques in buildings

**Defended before the jury composed of:**

M BOULAOUAD Abderachid	MCA University Med BOUDIAF-MSILA	President
M. RAHMANI Abdullah Yacine	MCA University Med BOUDIAF-MSILA	Encadrant
M BOUGUERRA Kheireddine	MCA University Med BOUDIAF-MSILA	Examiner

**Academic Year: 2023/2024**

## **Remerciement**

In the name of Allah, the Most Gracious, the Most Merciful.

All praise is due to Allah for the completion of this work after a long period of effort. We extend our sincere gratitude to everyone who contributed, whether directly or indirectly, to the completion of this dissertation. We ask Allah to make this work beneficial for us and for others.

I extend my deepest thanks and appreciation to our esteemed professor and supervisor, Dr. RAHMANI Abdullah Yassin, for his tremendous efforts, valuable advice, continuous support, and constant presence. Without him, this achievement would not have been possible.

We also extend our heartfelt thanks to the members of the examination committee for accepting to read and evaluate our work.

Our deep thanks and gratitude also go to our esteemed professors who accompanied us throughout our academic journey. Thank you for the knowledge, guidance, and direction you have provided.

**Bensenoussi Sounia**

# Sommair

General Introduction.....	2
<b>Chapter 01: Seismic behavior of RC buildings</b>	
1.1 Introduction.....	4
1.2 Earthquakes.....	4
1.2.1 Definition of earthquake.....	4
1.2.2 Earthquake characteristics.....	5
1.2.3 Causes of earthquakes.....	7
1.2.4 Seismic zones in the world.....	7
1.2.5 Seismic zones in Algeria.....	8
1.3 Seismic behavior of buildings.....	9
1.3.1. The effects of earthquakes on building.....	9
1.3.2. Methods of seismic analysis.....	11
1.4 RC building.....	13
1.4.1. Definition.....	13
1.4.2. Drawbacks of RC building .....	14
1.4.3. Seismic behavior of RC buildings.....	14
1.4.4. Seismic behavior of RC buildings.....	15
1.4.4.1. Seismic behavior of roof slabs.....	15
1.4.4.2. Seismic behavior of brick walls.....	15
1.4.4.3. Methods for placing beams and columns in seismic-resistant systems.....	16
1.5 Seismic assessment and retrofitting existed building.....	17
1.5.1. Survey.....	17
1.5.1.1. Rebar detection.....	17
1.5.1.2. Concrete tests.....	18
1.5.1.3. Steel tests.....	20
1.5.2. Modeling and analysis.....	20
1.5.3. Note.....	20
1.5.4. Techniques of retrofitting.....	21
1.5.3.1 Reinforced concrete jackets.....	21

1.5.3.2 New shear walls.....	21
1.5.3.3 Steel bracing.....	22
1.5.3.4 FRP Wrapping.....	23
1.5.3.5 Foundation strengthening.....	24
1.5.3.6 Seismic isolation.....	24
1.5.3.7 Steel Plates.....	25
1.6. Conclusion.....	26

## **Chapter 02 Seismic assessment of existing buildings**

2.1. Introduction.....	28
2.2. Assessment of damages and material properties in existing RC buildings.....	28
2.2.1. Rebar detection.....	28
2.2.2. Concrete tests.....	30
2.3. Structural modeling of the existing building.....	35
2.3.1. Methods of Analyses.....	36
2.3.2. Modelling of RC Structures.....	42
2.3.3. Checks and Acceptance Criteria.....	44
2.3.4. Modeling steps using SeismoBuild software.....	46
2.4. Conclusion.....	53

## **Chapter 03 Techniques of strengthening of existing buildings**

3.1. Introduction.....	55
3.2. Strengthening Techniques for the Retrofit of RC Buildings.....	55
3.2.1. Reinforced concrete jackets.....	55
3.2.2. New shear walls.....	58
3.2.3. Steel bracing.....	59
3.2.4. FRP Wrapping.....	61
3.2.5. Steel Plates.....	62

3.2.6. Resins and Repair Mortar .....	63
3.2.7. Seismic isolation.....	66
3.3. Foundation strengthening.....	66
3.4. Concluding remarks on the strengthening techniques .....	67
3.5. Conclusion.....	67

### **Chapter 04 Case Study**

4.1. Introduction.....	69
4.2. Description of the existed building .....	69
4.3. Building modeling.....	72
4.4. Code requirements.....	73
4.5. Results and discussion.....	73
4.5.1. Preliminary results.....	73
4.5.1. Pushover curves.....	74
4.5.3. Target displacement.....	75
4.5.1. Elements check.....	75
4.1. Building strengthen by adding shear walls.....	77
4.6.1. Reinforcements of the new shear walls.....	78
4.6.2. Periods and modal mass participation.....	78
4.6.3. Pushover curves.....	79
4.6.4. Target displacement.....	80
4.6.5. Capacity check.....	81
4.7. Building strengthen by elements jacketing.....	82
4.7.1 Reinforcements of the elements jacketing.....	83
4.7.2 Periods and modal mass participation.....	84

4.7.3 Pushover curves.....	85
4.7.4 Target displacement.....	86
4.7.5 Capacity check.....	86
4.8. Building strengthen by FRP wrapping. ....	87
4.8.1. FRP type.....	89
4.8.2. Periods and modal mass participation.....	89
4.8.3. Pushover curves.....	89
4.8.4. Target displacement.....	90
4.8.5. Capacity check.....	91
4.9. Conclusion.....	92
<hr/>	
General conclusion.....	94
Bibliographic reference.....	95

# List of Figures

## Chapter 01: Seismic behavior of RC buildings

Figure 1.1. The Kobe earthquake on 17 January 1995 with a magnitude of 6.9 on the Richter scale [1].....	4
Figure 1.2 Earthquake characteristics [2].....	5
Figure 1.3 the body waves (P and S) and surface waves recorded by a seismometer [2].....	6
Figure 1.4 movement of tectonic plates [2].....	7
Figure 1.5 Ring of fire zone [2].....	8
Figure 1.6. Alpine Himalayan belt [2].....	8
Figure 1.7 Seismic zones in Algeria [6].....	9
Figure 1.8 the building roof moves differently from the ground [7].....	10
Figure 1.9. The relative motion [8].....	10
Figure 1.9 Response spectrum [9].....	12
Figure 1.10 Pushover Analysis [9].....	13
Figure 1.11 RC buildings [8].....	13
Figure 1.12 Seismic behavior of brick walls [10].....	15
Figure 1.13. The correct methods for placing beams and columns in seismic-resistant systems [10]..	16
Figure 1.14 concrete rebar detection methodology [11].....	17
Figure 1.15 (a) Concrete specimen, and (b) Rotary cutting tool.....	18
Figure 1.16 execution of a rebound hammer test.....	19
Figure 1.17 execution of UPV test.....	19
Figure 1.18 Seismic structure evaluation results by modeling.....	20
Figure 1.19 Application of RC Jackets [8].....	21

Figure 1.20 Application of New shear walls [12].....	22
Figure 1.21 Types of bracing systems [13].....	23
Figure 1.22 application of FRP Wrapping [14].....	23
Figure 1.23 Foundation strengthening [15].....	24
Figure 1.24 Seismic base isolation [12].....	25
Figure 1.25 application of Steel Plates [16].....	25

## **Chapter 02 Seismic assessment of existing buildings**

Figure 2.1. Concrete rebar detection methodology [11].....	29
Figure 2.2. Rotary cutting tool.....	30
Figure 2.3. Concrete specimen after and before testing.....	31
Figure 2.4 Rebound Hammer.....	32
Figure 2.5 Test Procedures of Rebound Hammer.....	33
Figure 2.6. Ultrasonic Pulse Velocity (UPV).....	34
Figure 2.7. Test Procedure of Ultrasonic Pulse Velocity,(a) Direct Transmission,(b) Semi-Direct Transmission, and (c) Indirect (Surface) Transmission.....	35
Figure 2.8 The force takes the form of an inverted triangle [17].....	38
Figure 2.9 The pushover curve in SDOF system [18].....	39
Figure 2.10 The capacity curve (MDOF system) [18].....	40
Figure 2.11. Elastic Response Spectrum (MDOF system) [19].....	40
Figure 2.12 Transforming the Elastic Response Spectrum into the Demand Curve [19].....	41
Figure 2.13 Performance point [17].....	42
Figure 2.14. Element section modeling [12].....	43
Figure 2.15. Shear wall modelling with rigid offsets [12].....	43
Figure 2.16. Component Force vs. Deformation Curves [20].....	45
Figure 2.17 Building Modeler, a) 1st Floor, b) 2nd Floor.....	47

Figure 2.18 limit states available in the seismic code.....	48
Figure 2.19 knowledge level window.....	48
Figure 2.20 seismic action window.....	49
Figure 2.21 Analyses types window.....	49
Figure 2.22 Set the values of dead load and live load for the structure.....	50
Figure 2.23 specify the inspections we want to conduct on the structure.....	50
Figure 2.24 Eigenvalue analysis window.....	51
Figure 2.25 Eigenvalue analysis window.....	51
Figure 2.26 Checks Module (Member Shear Forces).....	52
Figure 2.27 Technical Report.....	52

### **Chapter 03 Techniques of strengthening of existing buildings**

Figure 3.1. Reinforced concrete jackets [8].....	56
Figure 3.2 Shotcrete jacketing [26].....	57
Figure 3.3 reinforcement of RC jacketing.....	57
Figure 3.4 application of New shear walls [27].....	58
Figure 3.5 Steel bracing [28].....	59
Figure 3.6 Typical (a) Eccentric Bracing Systems and (b) Eccentric Steel Braces Systems in retrofit [12].....	60
Figure 3.7 FRP Wrapping [14].....	61
Figure 3.8 application of FRP Laminates [14].....	62
Figure 3.9 application of Steel Plates [18].....	63
Figure 3.10. Cracks repair with epoxy resins [29].....	64
Figure 3.11. Repair with corrosion inhibitors and repair mortars [30].....	64
Figure 3.12. (a) Typical base isolation configuration and (b) the base isolation configuration [12]...65	65
Figure 3.13. Foundation strengthening [31].....	66

## Chapter 04 Case Study

Figure 4.1 Plan view of the studied building, a) 1st Floor, b) 2nd Floor.....	70
Figure 4.2 The dimensions and reinforcement of the shear wall.....	71
Figure 4.3 Reinforcement at the Start of the beam.....	71
Figure 4.4 Reinforcement at the Middle of the beam.....	71
Figure 4.5 Reinforcement at the End of the beam.....	72
Figure 4.6 3D view of the studied building.....	72
Figure 4.7. Pushover curves : a) modal +X b) modal -X, c) modal +Y, d) modal -Y.....	74
Figure 4.8. Members chord rotations of the studied building, a) For Damage limitation DL b) Significant damage SD.....	76
Figure 4.9. b) Members shear forces of the studied building, a) For Damage limitation DL b) Significant damage SD .....	76
Figure 4.9. Plan view of the Building strengthen by adding shear walls, a) First Floor, b) second Floor.....	77
Figure 4.10 3D view of the Building strengthen by adding shear walls.....	77
Figure 4.11 The dimensions and reinforcement of the new shear wall (W11, and W12).....	78
Figure 4.12 The dimensions and reinforcement of the new shear wall w10.....	78
Figure 4.13. Pushover curves of the Building strengthen by adding shear walls in x Direction, a) modal +X b) modal -X, c) modal +Y,d) modal -Y.....	80
Figure 4.14. Members chord rotations of the Building strengthen by adding shear walls, a) For Damage limitation DL b) Significant damage SD.....	81
Figure 4.15. Members shear forces of the Building strengthen by adding shear walls, a) For Damage limitation DL b) Significant damage SD.....	82
Figure 4.16. Plan view of the Building strengthen by elements jacketing, a) First Floor, b) second Floor.....	83
Figure 4.17 3D view of the Building strengthen by elements jacketing.....	83

Figure 4.18. Pushover curves of the Building strengthen by elements jacketing in Direction, a) modal +X b) modal -X, c) modal +Y,d) modal -Y.....	85
Figure 4.19. Member's chord rotations of the Building strengthen by elements jacketing, a) For Damage limitation DL b) Significant damage SD.....	87
Figure 4.20. Members shear forces of the Building strengthen by elements jacketing, a) For Damage limitation DL b) Significant damage SD.....	87
Figure 4.21.1an view of the Building strengthen by FRP wrapping, a) First Floor, b) second Floor..	88
Figure 4.22.D view of the Building strengthen by FRP wrapping.....	88
Figure 4.23.ushover curves of the Building strengthen by FRP wrapping in Direction, a) modal +X b) modal -X, c) modal +Y d) modal -Y.....	90
Figure 4.24.embers chord rotations of the Building strengthen by adding shear walls, a) For Damage limitation DL b) Significant damage SD.....	91
Figure 4.25.embers shear forces of the Building strengthen by FRP wrapping, a) For Damage limitation DL b) Significant damage SD.....	92

# List of table

## Chapter 01: Seismic behavior of RC buildings

Table 1.1 the method for seismic analysis .....	11
---	----

## Chapter 02 Seismic assessment of existing buildings

Table 2.1: Limitations in the use of the different analysis methods [12].....	37
---	----

## Chapter 03 Techniques of strengthening of existing buildings

Table 3.1.comparison of the most important repair and strengthening techniques for RC building [12].....	67
--	----

## Chapter 04 Case Study

Table 4.1 The dimensions and reinforcement of the columns.....	70
Table 4.2. Modal characteristics of the studied building.....	73
Table 4.3. Target displacement.....	75
Table 4.4. Modal characteristics of the Building strengthen by adding shear walls.....	79
Table 4.5. Target displacements.....	81
Table 4.6 The dimensions and reinforcement of the columns jacketing .....	84
Table 4.7. Modal characteristics of the Building strengthen by elements jacketing.....	85
Table 4.8. Target displacements.....	86
Table 4.12. Modal characteristics of the Building strengthen by FRP wrapping.....	89
Table 4.13. Target displacements.....	90

## ملخص

تقيّم هذه المذكرة فعالية تقنيات تعزيز الهياكل المختلفة - الجدران القصية، والتغليف، واللفائف البوليمرية المدعمة بالألياف (FRP) - في تحسين أداء المباني الزلزالي. من خلال تحليلات مفصلة، بما في ذلك تحليل الدفع المتدرج، والإزاحات المستهدفة، ودوران العناصر والمقاطع، وفحص قوى القص، تقيّم الدراسة تأثير كل طريقة على استجابة الهيكل تحت الأحمال الزلزالية. تُظهر النتائج أن الجدران القصية توفر تحسينات معتدلة في الصلابة ومقاومة القص، لكنها لا تعزز الأداء الشامل بشكل جيد. تزيد اللفائف البوليمرية المدعمة بالألياف (FRP) من قدرة الإزاحة وتوفر مقاومة معتدلة للقص، مما يجعلها حلاً مرناً ولكنه أقل صلابة. بالمقابل، يقلل التغليف بشكل كبير من دورانات المقاطع وقوى القص، مما يوفر أفضل تحسين شامل في المرونة الزلزالية. تشير النتائج إلى أن التغليف هو الطريقة الأكثر فعالية لتعزيز الزلزالي الشامل، مما يوفر رؤية قيمة لتحسين سلامة المباني وتمانتها في المناطق المعرضة للزلازل.

**الكلمات المفتاحية:** الأداء الزلزالي؛ تعزيز الهياكل؛ الجدران القصية؛ التغليف؛ اللفائف البوليمرية المدعمة بالألياف (FRP)

## Abstract

This dissertation evaluates the effectiveness of various structural strengthening techniques—shear walls, jacketing, and Fiber Reinforced Polymer (FRP) wrapping—in enhancing the seismic performance of buildings. Through detailed analyses, including pushover analysis, target displacements, chord rotations, and shear force checks, the study assesses each method's impact on structural response under seismic loads. The results show that shear walls provide moderate improvements in stiffness and shear resistance but do not uniformly enhance overall performance. FRP wrapping increases displacement capacity and offers moderate shear resistance, making it a flexible yet less stiff solution. Conversely, jacketing significantly reduces chord rotations and shear forces, providing the best overall improvement in seismic resilience. The findings suggest that jacketing is the most effective method for comprehensive seismic strengthening, offering valuable insights for improving building safety and durability in earthquake-prone areas.

**Keywords:** Seismic Performance; Structural Strengthening; Shear Walls; Jacketing; FRP Wrapping

# **General Introduction**

## General Introduction

Seismic risk poses a significant threat to human safety, economic stability, and infrastructure integrity worldwide. Recent earthquakes, such as the 2023 Morocco earthquake and the devastating Turkey-Syria earthquakes on February 6, 2023, have highlighted the persistent danger posed by seismic activity. These events caused substantial loss of life and extensive damage to infrastructure, underscoring the urgent need for effective seismic risk mitigation strategies.

In Algeria, the seismic risk is notably high due to its location near the convergence zone of the African and Eurasian plates. The 2003 Boumerdès earthquake serves as a stark reminder of this vulnerability, causing widespread destruction and significant casualties. This event emphasized the critical importance of implementing robust earthquake-resistant measures in building design and construction to safeguard lives and property.

A well-designed building can withstand seismic motions by incorporating modern seismic codes and construction practices. However, many existing buildings may not comply with these newer standards, especially those constructed before the introduction of contemporary seismic design codes. Therefore, assessing and retrofitting these older structures is crucial to ensure they can endure future seismic events. Unfortunately, Algeria lacks comprehensive guidelines to direct engineers in the systematic assessment and strengthening of these buildings.

This study examines various retrofitting techniques for reinforced concrete (RC) buildings, employing pushover analysis as a primary assessment method. Pushover analysis, an incremental static analysis technique, helps evaluate the seismic performance of structures by simulating their response to increasing lateral loads. Our work aligns with the European seismic code, Eurocode 8, to ensure the reliability and effectiveness of the proposed strengthening schemes.

The dissertation is organized into four chapters. The first chapter discusses seismic risk and its impact on buildings, the seismic behavior of RC buildings, and the methods used for structural analysis, along with a brief overview of various strengthening techniques. Chapter two delves into the specific techniques used to strengthen buildings and the assessment methodologies. Chapter three focuses on the analysis methods employed to evaluate existing buildings' seismic performance. Finally, chapter four presents a case study, applying the concepts discussed in the previous chapters to an actual RC building using Eurocode 8. We will extract results, propose various strengthening schemes, and compare their effectiveness

**Chapter 01**

**Seismic behavior of RC**

**buildings**

## 1.1 Introduction

Earthquakes are rapid vibrations of the earth's surface that occur suddenly due to the breaking of rocks deep within the earth, causing significant damage depending on the earthquake's intensity. The severity of earthquakes varies from one area to another, with some regions experiencing high seismic activity, others low, and some moderate. Many old RC buildings were constructed according to outdated and ineffective seismic standards. Therefore, it is necessary to conduct an inspection and evaluation of these structures to determine their seismic behavior and carry out the necessary renovation work accordingly.

In this chapter, we explain the seismic behavior of New/existing reinforced concrete buildings.

## 1.2 Earthquakes

### 1.2.1 Definition of earthquake

It is a natural phenomenon resulting from the sudden breaking of rocks in the ground due to geological influences (movement of tectonic plates, volcanoes.....), it results in the release of potential energy in the form of rapid and successive seismic waves, its intensity can be measured using the Richter scale.

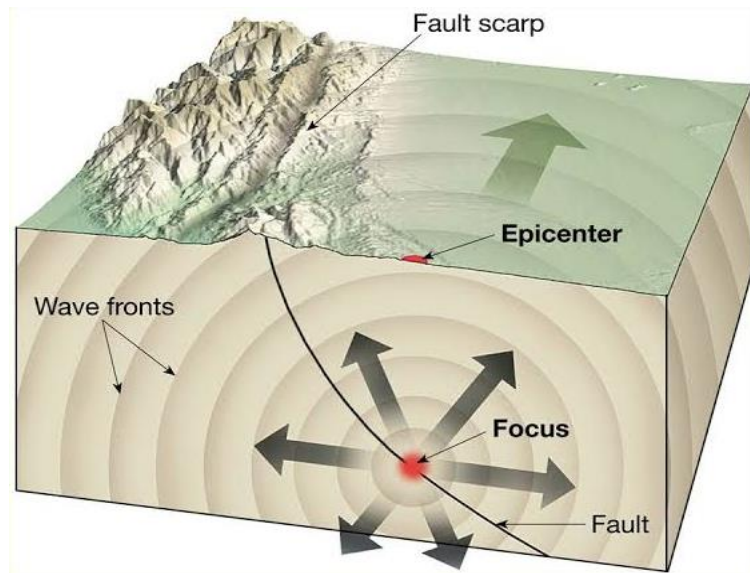
The intensity of the earthquake ranges from strong mild shakes that people do not feel to powerful shakes capable of causing destruction.



**Figure 1.1.** The Kobe earthquake on 17 January 1995 with a magnitude of 6.9 on the Richter scale[1].

## 1.2.2 Earthquake characteristics

The characteristics of earthquakes depend on several factors such as their magnitude, depth of focus, distance from the epicenter, and types of tectonic movement of the earth causing the earthquake, such as (sliding, subduction, or splitting), which can result in earthquakes of varying intensities and surface cracks in building. Some characteristics of earthquakes include:



**Figure 1.2** Earthquake characteristics [2].

- **Focus**

The focus is an area where rocks in the earth's interior are fractured.

- **Epicenter**

It is the area located on the earth's surface and perpendicular to the focus.

- **Seismic waves**

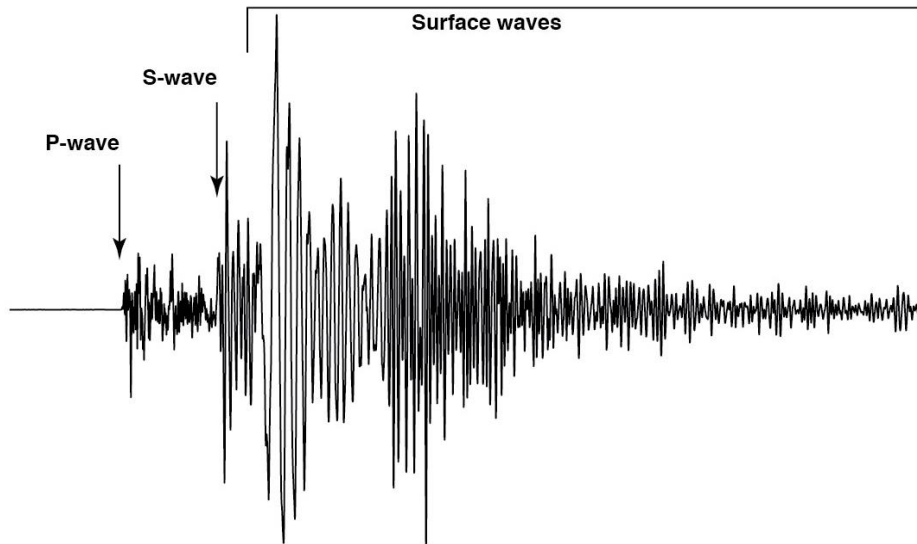
Seismic waves are generated by the cracking of rocks, its speed varies depending on the medium it crosses reaching (7 km/s or 8 km/s) in solid and interconnected rocks, and less than a 1km/s in brittle rocks.

➤ There are different types of seismic waves, including:

**P-waves (primary waves):** these waves propagate through rocks, liquids, and air by alternating compression and expansion. They travel very quickly compared to other types of waves and are the first waves recorded by a seismograph due to their speed.

**S-waves (secondary waves):** these waves move through rocks horizontally and do not pass through liquids and air. They are slower than P-waves.

**Surface waves:** these waves travel along the surface of the earth when seismic waves reach the earth's surface, causing the tremors we feel.



**Figure 1.3** the body waves (P and S) and surface waves recorded by a seismometer [2].

- **Movement of tectonic plates**

Tectonic plates are constantly moving in different directions due to temperature pressure in the earth's interior.

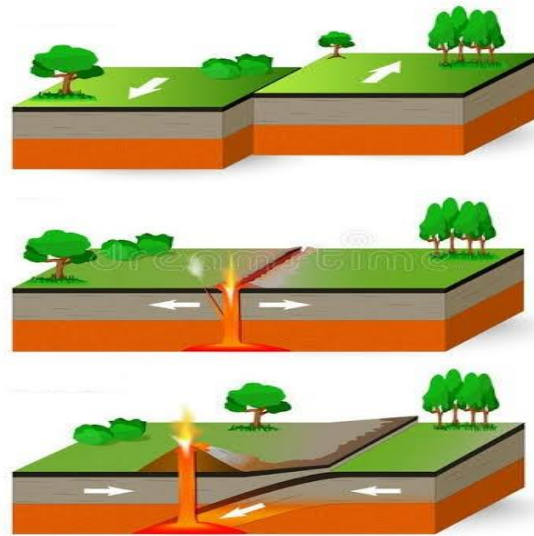
This results in the formation of folds that form mountain ranges if the rocks are flexible fault that cause earthquakes if the rocks are solid.

➤ Three main types of plate motion are identified:

**Transduction:** Plates slide sideways.

**Divergent:** When plates are moving away from each other.

**Convergent:** When plates move toward each other.



**Figure 1 .4** movement of tectonic plates [2].

It produces energy in the form of seismic waves that people feel.

### 1.2.3 Causes of earthquakes

The earthquake results from the sudden breaking of rocks in the earth's interior, primarily as a result of the continuous movement of tectonic plates in various directions over thousands of years due to changes in temperature deep within the earth. This movement can lead to the formation of mountain ranges if the rocks are flexible, or faults that causes earthquakes if the rocks are rigid.

However, plate tectonics is not the sole cause of earthquakes, human activities also play a role in disrupting the geological balance of the earth, such as resource extraction, groundwater depletion, and nuclear testing. Additionally, volcanic eruptions can trigger rocks movements and collapses, contributing to seismic events.

### 1.2.4 Seismic zones in the world

Earthquakes can occur at any time and in different regions of the world, but some areas are more prone to earthquakes than others. According to the world atlas [3], five countries are classified as the most earthquakes-prone, including China, Indonesia, Iran, Turkey, and Japan. Additionally, there are three major tectonic belts where most of the world's earthquakes occur, as identified by the British geological survey [4] and the United States Geological Survey [5], these belts are as follows:

- **Ring of fire:** It is the largest earthquake belt in the world (80% of the world's earthquake), located in the Pacific Ocean.
  - The largest earthquake in this region was in Chile in 1960 with a magnitude of 9.5 to Richter.

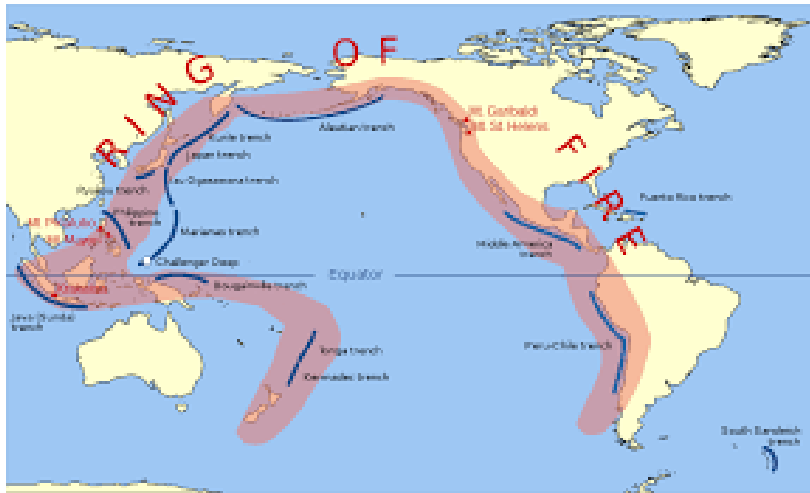


Figure 1.5 Ring of fire zone [2].

- **Alpine Himalayan belt (Alps):** The second most earthquake threatened area (17 % of the world's earthquakes), includes in Himalayan region in the south Asia, the island of Java, the Mediterranean Sea and the Atlantic Ocean.
  - The largest earthquake in this region was in 2004 with a magnitude of 9.1 to Richter.

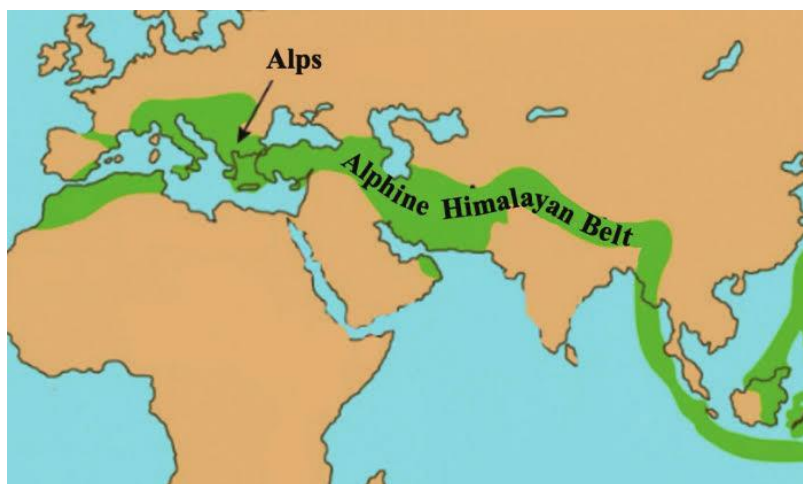


Figure 1.6. Alpine Himalayan belt [2].

- **Mid-atlas belt:** It is located under water and rarely affects human life.

### 1.2.5 Seismic zones in Algeria

Algeria is located in an active seismic zone due to its geographical location, where it lies in the region of the “atlas middle belt” where tectonic plates intersect. The most earthquakes-prone areas in

Algeria are in the north of the country, especially along the coast of the Mediterranean Sea, such as the Sidi Fredj area and the capital Algiers.

In recent years, Algeria has experienced several significant earthquakes, including the mascara earthquake in 1994 measuring 5,9 on the Richter scale, the Ain Temouchent earthquake in 1999 measuring 5,6 on the Richter scale, the Boumerdes earthquake in 2003 measuring 6.8 on the Richter scale, this has increased the importance of studying and identifying seismic zones in Algeria.

Algeria is classified into five seismic zones according to the Algerian seismic code RPA 99 V 2003 [5]:

- **Zone 0:** there no seismic activity.
- **Zone I:** weak seismic activity.
- **Zone IIA et IIB:** is an area of moderate seismic activity.
- **Zone III:** is the most active earthquake zone.

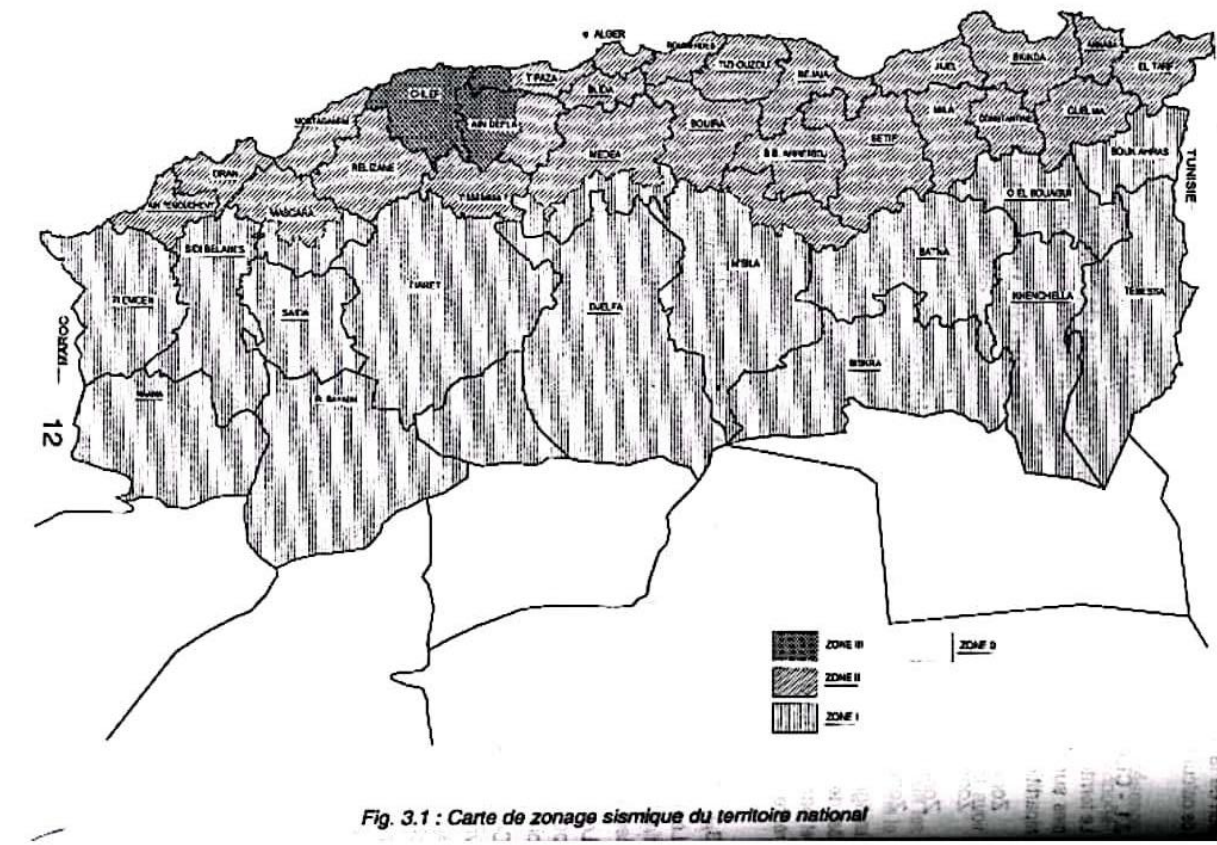


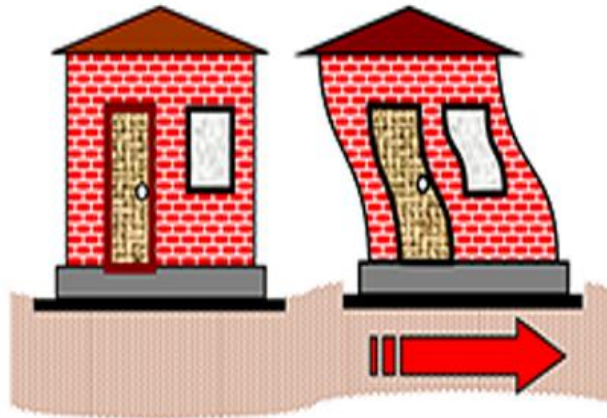
Figure 1.7 Seismic zones in Algeria [6].

## 1.3 Seismic behavior of buildings

### 1.3.1. The effects of earthquakes on building

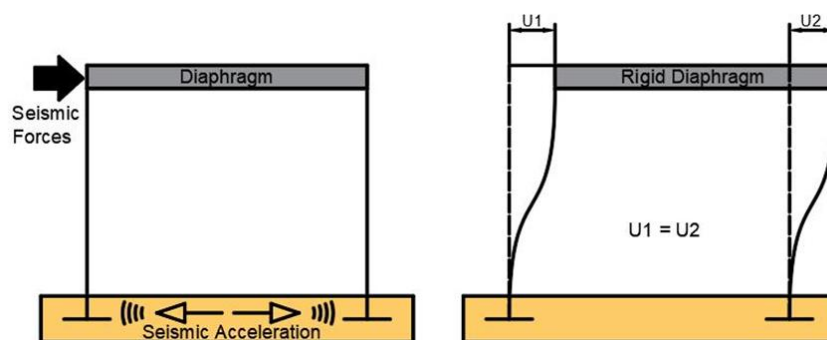
When an earthquake affects a building, the base of the building moves and the roof remains stationary according to **Newton's first law of the motion**: [the roof tends to hold in its initial position].

But the roof is pulled to the base of the building since the columns connect the base and the roof, this creates pressure on weak columns and joints that can cause the structure to shear.



**Figure 1.8** the building roof moves differently from the ground [7].

During an earthquake, the ground shakes randomly back and forth in all directions (X, Y, Z), the engineers design all structures with the aim of supporting the weight of earth's gravity to bear the vertical loads, however they must also consider that the structures are designed to withstand horizontal forces, and this is done by strengthening the floor slab and columns.



**Figure 1.9.** The relative motion [8].

### 1.3.2. Methods of seismic analysis

Structures are subjected to seismic loads that adversely affect them, requiring special attention in the field of civil engineering. To design structures appropriately, it is necessary to understand how seismic loads impact them by familiarizing ourselves with seismic analysis methods, including the following:

**Table 1.1** the method for seismic analysis.

Analysis	Elastic	Non linear
Static	Equivalent static analyses	Nonlinear dynamic analysis
Dynamic	Response spectrum analyses	pushover analyses

- **Equivalent static analyses**

The Equivalent static analyses method is widely used in civil engineering, although it may lack accuracy for certain types of structures. This method works to convert the dynamic seismic force that affects the building in the horizontal direction according to the main axes of the building. These forces are determined according to international seismic codes, including the necessary standards for seismic resistance such as (RPA99V2003 [6]).

By this method, we can calculate the equivalent horizontal force (from RPA99V2003):

$$V = \frac{A \cdot D \cdot Q \cdot W}{R} \quad 1.1$$

A: zone acceleration coefficient: It depends on the importance of the buildings and the seismic zone.

D: average dynamic amplification factor: function of the fundamental period (T) of the structure, and category of site of the damping correction factor ( $\eta$ ).

Q: the quality factor of the structure: function of:

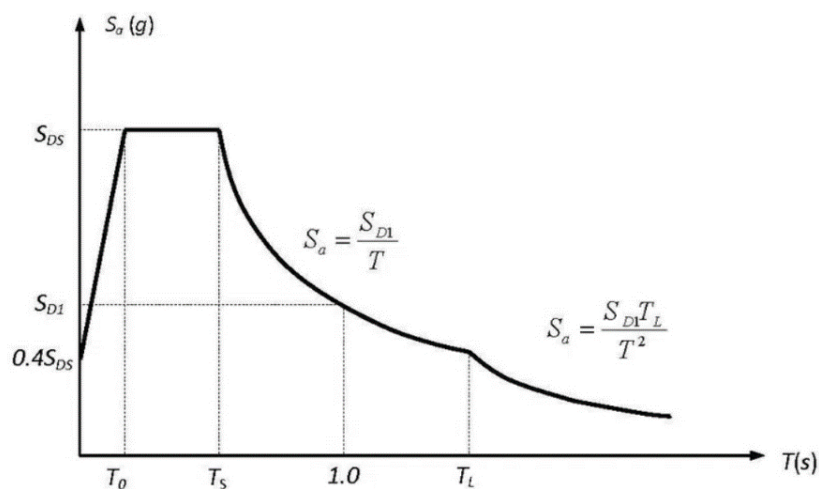
- The redundancy and geometry of the elements that constitute it.
- Regularity in plan and elevation.
- The quality of construction control.

R: overall structural behavior coefficient.

W: total weight of the structure

- **Response spectrum analyses**

This method relies on creating a graphical representation between the maximum structural response of the building and the frequency (T) called **Response spectrum**, to assess the building's seismic loads. A hysteresis loop is generated by incrementally increasing the frequency and recording the maximum structural response each time, this process is repeated, and constructed based on the obtained results.



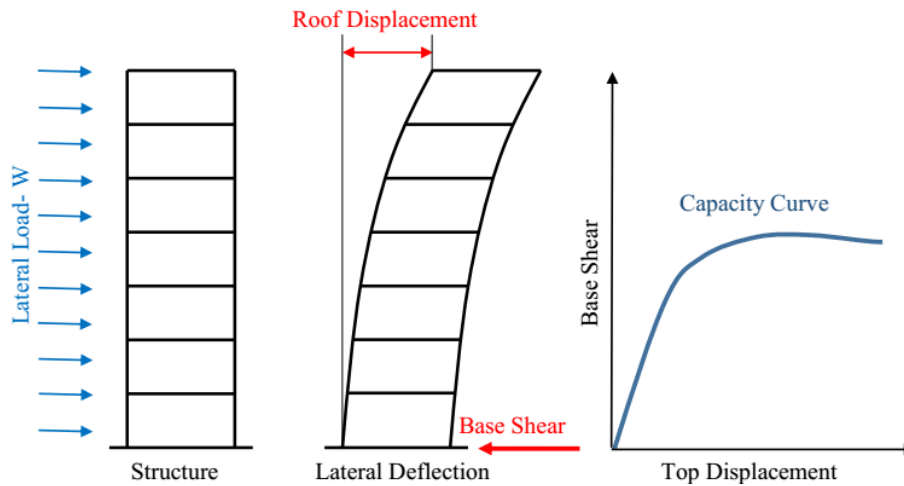
**Figure 1 .9** Response spectrum [9].

- **Nonlinear dynamic analysis**

Nonlinear dynamic analysis is the most accurate and complex method in terms of application. It provides a detailed representation of the structural time response by integrating the equation of motion to study the seismic behavior of the structure.

- **Pushover analyses**

This method is also called **static nonlinear analysis**, it evaluates the structure's ability to withstand increasing horizontal seismic loads until collapse, aiming to study the seismic behavior of the structure and identify its weak joints. It relies on determining two essential elements: the demand spectrum and the capacity spectrum. The intersection of the demand spectrum with the capacity spectrum at the performance points is used to verify whether the structure has exceeded the considered damage level.



**Figure 1.10** Pushover Analysis [9].

## 1.4 RC building

### 1.4.1. Definition

The reinforced concrete building are building in which reinforced concrete is used as the primary material in their construction. They are characterized by their strength and ability to withstand heavy loads due to the inclusion of reinforcement materials such as steel.

The RC building are among the most widespread and important types of buildings worldwide, as they are ideal for use in various structures such as towers, bridges, residential building, and other large facilities.



**Figure 1.11** RC buildings [8].

### 1.4.2. The advantages of RC building

RC buildings are the most famous and widely used type of buildings in the world, as they possess immense strength and durability due to the combination of steel tensile forces with concrete compressive forces. Concrete has low permeability to chemicals, making it corrosion-resistant, and it is also weather-resistant, able to withstand heat for 2 to 6 hours without igniting or burning. The materials used in RC buildings are available worldwide and are cost-effective compared to other construction materials, making them economical.

RC buildings can be designed in various sizes and shapes according to project needs, as concrete is initially in a liquid state during manufacturing, allowing for flow, and steel bars can be bent into various shapes. The most important advantages of RC buildings is that they exhibit cracks or deflection in the structure or element when subjected to excess loads due to winds, earthquakes, or excessive building weight, allowing engineers to take appropriate measures to prevent further damage.

### 1.4.3. Drawbacks of RC building

Despite the benefits of reinforced concrete buildings, they also have some drawbacks, including:

- Increased weight of the concrete structure due to the use of large quantities of heavy materials to construct it, unlike other structures made of wood, steel, or glass.
- Difficulty in modifying the concrete structure.
- Occurrence of aesthetic deformations in the reinforced concrete structure due to the corrosion of the reinforcement steel caused by seawater or de-icing salts.
- RC buildings require a lot of space and labor.

### 1.4.4. Seismic behavior of RC buildings

RC buildings consist of both architectural and structural element. The structural element are responsible for the stability of the building and bearing weights, including roof slabs, beams, columns, foundations, and reinforced concrete walls, cracks in these elements can be very dangerous. Architectural element, on the other hand, are created in the spaces between columns and roof to divide the building and are usually made of bricks, cracks in these elements are usually less severe.

Each structural element of the building is supported by foundations, which are directly supported by the ground, and the seismic force is proportional to the rigidity and mass of the building, primarily affecting the roof slabs, then transferring through beams, columns, and foundation.

Therefore, the lower structural elements such as columns and foundations must be designed stronger than the upper elements.

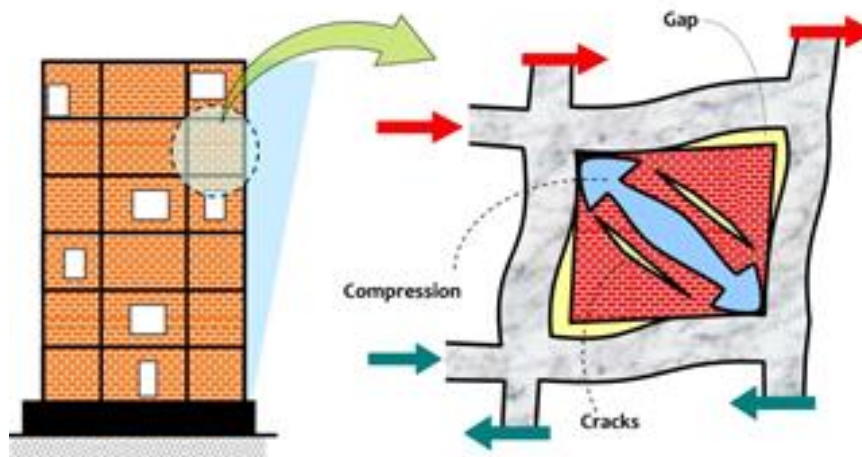
Each building has its own capacity to withstand seismic loads, hence the creation of the curve representing the structure's seismic demand.

#### 1.4.4.1. Seismic behavior of roof slabs

The majority of the building's mass is concentrated in the roof slabs. Since seismic forces are proportional to the building's mass, during an earthquake, these forces affect the elevation of the roof slabs. When the slabs move horizontally, they drag the beams along impacting the columns as well since the movement of the beams causes the columns to move in the same direction. When the beams move vertically, the slabs bend with them, as illustrated in.

#### 1.4.4.2. Seismic behavior of brick walls

As previously mentioned, during an earthquake, forces transfer from the beams to the columns, causing horizontal movement. Brick walls resist this movement, but due to their weak load-bearing capacity, they develop cracks when subjected to maximum load. Engineers can repair these cracks to preserve the building.

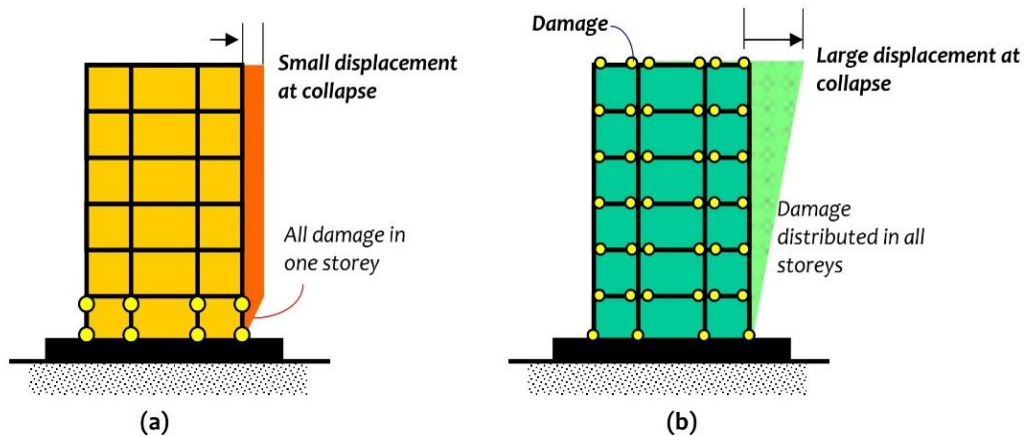


**Figure 1.12** Seismic behavior of brick walls [10].

#### 1.4.4.3. methods for placing beams and columns in seismic-resistant systems

During the design of structural elements for a building, the foundations must be stronger than the columns must be stronger than the beams (**Figure 1.13**. If the columns are designed to be weaker than

the beams, they will sustain severe damage, potentially leading to the collapse of the building. Conversely, if the structure is designed such that the lower members are stronger than the upper members, the building will sustain gradual damage starting from the beams, and necessary measures can be taken to repair it.



**Figure 1.13.** The correct methods for placing beams and columns in seismic-resistant systems[10].

## 1.5 Seismic assessment and retrofitting existed building

The process of evaluating existing buildings and facilities is an essential step in order to mitigate seismic danger, aiming to determine the extent of resistance to seismic works and the degree of general safety of the site studied in order to make the appropriate decision to strengthen or demolish.

This process is generally done using engineering programs such as (SeismoBuild, Sap 2000, Etabs....), in order to easily understand the design and behavior of the RC building.

The economic aspect must also be taken into account, as sometimes the process of evaluation and restoration is more expensive than the process of constructing a new building.

### 1.5.1. Survey

During the evaluation process, the geometry and dimensions of the components and the longitudinal and transverse reinforcement of the building must be determined, this is done by accessing the built drawings if possible, because sometimes they may not be available, and the drawing may not

reflect the actual condition of the building. There is always a need for comprehensive investigations on the site and recording all deviations from the original design, Engineers may also face problems during the survey process if the structure is covered with (gypsum, wood or backfill in the foundations, as it will be difficult and expensive to detect them.

#### 1.5.1.1. Rebar detection

Rebar is detected using a scanner (non-destructive test) that can be connected to external monitors or laptops, as most scanner are manually operated and battery operated in order to be used on any construction site.

The scanner are placed on the concrete surface, and the scanning process appears on the screen connected to it, showing the position, number and size of the reinforcement in the form of a two-dimensional image that can be saved on the computer.



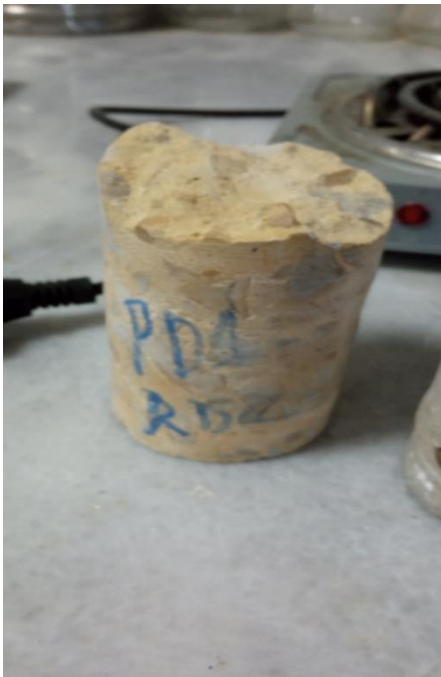
**Figure 1.14** concrete rebar detection methodology [11].

### 1.5.1.2. Concrete tests

- **Rotary cutting tool (destructive tests)**

Using a rotary cutting tool to obtain a cylindrical sample with a diameter of 10 or 15 cm and its edges are unequal. Care must also be taken in choosing the cutting location so that the rebar is not cut into the core, and the hole must be immediately closed with concrete.

- A sample is taken and the properties of concrete are tested, and it is considered the most reliable method for this.



(a)



(b)

**Figure 1.15** (a) Concrete specimen, and (b) Rotary cutting tool.

- **Rebound hammer (non-destructive tests)**

It is used to evaluate the compressive strength of concrete. The rebound hammer is pressed vertically on the surface of the concrete, and its indicator shows the hardness value of the concrete rigidity, this test is most common for concrete.



**Figure 1.16** execution of a rebound hammer test.

- **Ultrasound pulse velocity test (non destructive tests)**

It evaluated the homogeneity and integrity of the concrete in order to determine the strength of the concrete. This process is done by placing the two ends of the device (a pulse generator and a pulse receiver) in two opposite directions, so the pulse generator sends ultrasound waves towards the pulse receiver and measures their arrival speed. The higher the pulse speed, the greater the elasticity coefficient thus making the concrete stronger and safer.

- Pulse paths must also be chosen so as to avoid rebar.



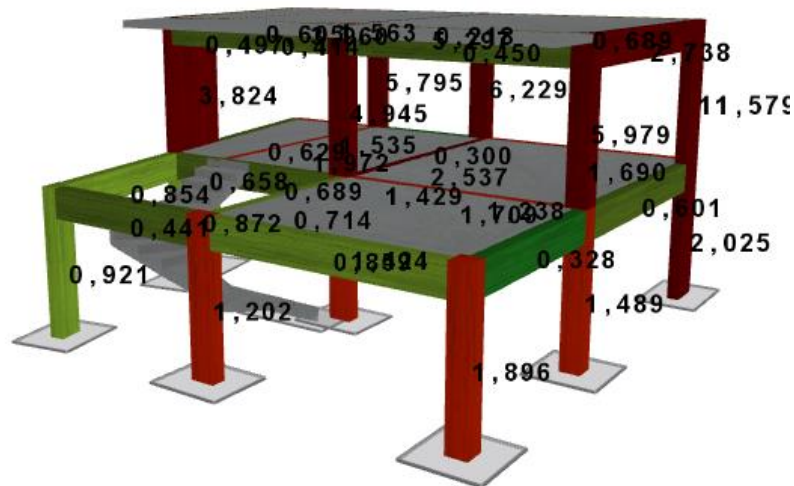
**Figure 1.17** execution of UPV test.

### 1.5.1.3. Steel tests

Steel can be tested by visual inspection, where it can be determined whether it is (smooth, ribbed, oxidized and corroded).

### 1.5.2. Modeling and analysis

After determining the characteristics of the complete configuration of the building structure, we enter all the information into the program in order to carry out the necessary calculations and checks, we can thus verify whether the structure is safe or needs upgrading.



**Figure 1.18** Seismic structure evaluation results by modeling.

### 1.5.3. Note

During the design phase, the four previously mentioned of seismic analysis methods can be used, the Equivalent static analyses and Response spectrum analyses is considered the most widely used and the simplest in design.

- Engineering programs (SAP2000, Robot and Etabs) can be used for the design process. During the evaluation phase, only the dynamic seismic analysis methods (pushover analyses and nonlinear dynamic analyses) can be used.
- Engineering programs (SAP2000, SeismoBuild and Etabs) can be used for the evaluation process.

## 1.5.4. Techniques of retrofitting

Building retrofitting involves a wide range of methods and techniques aimed at repairing and strengthening damaged structures. Among these methods are foundation reinforcement, column strengthening, wall reinforcement, and repairing cracks using durable filling materials. The goal of building retrofitting is to enhance durability and safety, and reduce the negative impacts of damages caused by earthquakes and other environmental conditions. Some of retrofitting techniques including:

### 1.5.3.1 Reinforced concrete jackets

The methods works to add a layer of a reinforced concrete in the form of a jacket by adding longitudinal and transverse reinforcement, where concrete forms are installed around the existing column, in order to avoids in the concrete and to be able to place longitudinal and transverse reinforcement, the thickness of the casing must exceed 10 cm.

The new and old rebar must also be connected together using steel nails or sometimes welding, in order to avoid welding (quick corrosion welding), the longitudinal reinforcement must extend from the foundation to the entire height of the building.



**Figure 1.19** Application of RC Jackets [8].

### 1.5.3.2 New shear walls

This technique works to create a reinforced concrete wall. in order to avoid the building rotating around to the center of the mass, at least two identical walls must be placed in each horizontal direction, while trying to avoid closing openings such as (doors, windows, balconies...).

New shear walls also provides a large proportion on the structure's rigidity and ductility with which it can resist seismic forces.



**Figure 1.20** Application of New shear walls [12].

### 1.5.3.3 Steel bracing

The braces are installed directly on the concrete frame, as they contribute to the lateral resistance of the structure. The braces must be installed in symmetrical positions relative to the center of mass in order to avoid unwanted twisting of the structure.

➤ There are two types of Steel bracing systems:

**Concentric steel bracing (X-shaped):** steel braces are installed in an X-shape where they meet in one center, and they are used to adjust concrete frames.

**Eccentric steel bracing (V-shaped):** steel braces are installed in an inverted V-shape, and this type is not commonly used to adjust concrete frames.



**Figure 1.21** Types of bracing systems [13].

#### 1.5.3.4 FRP Wrapping

A Fiber reinforced polymer consists of carbon, glass, or aramid. The advantages of it are low weight, ease of installation, and it also has high resistance to corrosion, one of its disadvantages is that it is not resistant to fire and is easily flammable. FRP fibers are applied as external reinforcement to existing reinforced concrete members, resulting in a huge increase in structural and shear forces, but they do not increase the rigidity of the reinforced concrete members applied to them or the rigidity of the entire structure.



**Figure 1.22** application of FRP Wrapping [14].

### 1.5.3.5 Foundation strengthening

Reinforcing the foundation requires digging through the entire building at ground level, so it is a very troublesome and expensive job. It is rarely used, it is used only in the case of liquefaction of the soil or lack of sufficient reinforcement in the foundations due to the absence of supervision.



**Figure 1.23** Foundation strengthening [15].

### 1.5.3.6 Seismic isolation

It is an effective method to protect structures from earthquake forces, as the superstructure is separated from the foundation that rests on shaky ground, preventing seismic acceleration from passing to the superstructure. Thus, this system is characterized by the ability to bear lateral load and high elastic strength, which helps the structure resist earthquakes.



**Figure 1.24** Seismic base isolation [12].

### 1.5.3.7 Steel Plates

Steel plates provides advantages similar to FRP strips, as it helps increase construction and shear forces and does not increase the stiffness of the RC members to which it is applies. Steel plates are applied to existing reinforced concrete members by dowels one of the disadvantages of steel is that it corrodes quickly.



**Figure 1.25** application of Steel Plates [16].

## 1.6 Conclusion

In conclusion, earthquakes pose a significant challenge to human life and infrastructure, necessitating effective strategies to mitigate their negative effects on buildings. We have reviewed the seismic behavior of buildings and RC buildings, emphasizing the importance of understanding it to improve their design and construction in a way that more effectively resists earthquakes.

We also discussed some assessment and retrofitting methods that can be adopted to enhance old buildings, highlighting the importance of embracing modern design techniques to increase their resilience.

This encourages continued research and innovation in the field of designing and retrofitting infrastructure to address future challenges related to earthquakes, emphasizing the necessity of adhering to international seismic standards in construction and retrofitting phases to ensure the safety of human life and property.

# **Chapter 02**

## **Seismic assessment of existing buildings**

## **2.1. Introduction**

Before strengthening an existing building against seismic effects, it is crucial to conduct a comprehensive assessment to understand the building's current characteristics. This assessment involves performing various experiments and analyses to evaluate the structural integrity, material properties, and existing damages. Key tests may include non-destructive testing, material sampling, and structural modeling to identify vulnerabilities. Accurate knowledge of these parameters is essential to design effective retrofitting strategies that enhance the building's seismic resilience. This preparatory step ensures that the strengthening measures are both efficient and tailored to the specific needs of the building.

In this chapter, we first discuss the existing experiments used to evaluate and measure the damage and material properties in existing buildings to accurately assess the current state of the structure. Following this, we delve into the structural modeling of the existing building using the actual material properties obtained from these assessments. For this modeling, the SeismoBuild software is employed, allowing for a detailed and precise simulation of the building's behavior under seismic loads.

## **2.2. Assessment of damages and material properties in existing RC buildings**

In some cases, construction information such as drawings and material properties may be unavailable or may not accurately reflect the building's current condition. Consequently, comprehensive on-site investigations are essential to document any deviations from the original design. Engineers often face challenges during the survey process, particularly when structural elements are obscured by materials like gypsum, wood, or foundation backfill, which can complicate detection and increase costs.

### **2.2.1. Rebar detection**

For building evaluation processes, it is necessary to detect the reinforcement steel. This can be done using a scanner that connects to external screens or laptops. Most optical scanners operate manually and are battery-powered to facilitate inspection at construction sites.

#### **a) Operation method of the scanners**

The scanner is placed directly on the surface of the reinforced concrete and connected to a screen or laptop. The scan results appear on the connected screen, showing the position, quantity, and size of the reinforcement in the form of a two-dimensional image that can be saved on the computer. Subsequently, small portions of the concrete cover are removed, allowing for direct measurement and inspection of the reinforcement steel to verify the accuracy of the scanner.



**Figure 2.1.** Concrete rebar detection methodology [11].

#### b) Steel tests

Rebar can be inspected through visual examination by checking the surface characteristics to determine if the steel is smooth or ribbed, and by looking for any visible signs on the bars such as corrosion. These observations, along with the construction history and types of steel used during that period, provide sufficient information for classification.

If there are doubts about the reliability of classification through visual inspection, especially if the rebar is corroded, mechanical testing can be employed to determine the main properties of the rebar, such as ultimate strength, yield strength, and ductility. It is important to consider potential changes in steel properties and conservatively account for reduced ductility.

To measure the yield strength and ultimate strength of the steel, a sample of rebar (at least 30 cm in length to obtain more accurate test results) is extracted by removing the concrete cover. Immediately after taking the sample, a new rebar of the same diameter should be fixed to restore the continuity of the reinforcement. The sample is then subjected to a tensile test to determine its mechanical properties. Steel tests are usually less common than concrete tests due to the lack of specialized laboratories for this analysis.

### 2.2.2. Concrete tests

Concrete testing methods vary according to the working method and the structural requirements for the inspection process, including destructive and non-destructive methods. Here are some methods for testing concrete:

#### a) Rotary Core Sampling Method (Destructive Methods)

Core extraction is considered the best method for evaluating the mechanical properties of concrete in existing structures. A cylindrical sample with a diameter ranging from 10 to 15 cm is extracted and subjected to tests to determine compressive strength, tensile strength, and modulus of elasticity.



Figure 2.2. Rotary cutting tool.

#### a-1) Method to extract samples

Using a rotary tool with diamond-tipped heads, a cylindrical sample with a diameter typically between 10-15 cm is extracted and cut. During the cutting process, it is crucial to avoid including reinforcing bars in the sample, as this can artificially reduce the measured strength. To prevent this, the concrete surface is scanned with a metal detector before cutting.

After extracting the sample, the extraction site is immediately filled with repair concrete of similar strength and non-shrink properties to maintain the structural integrity.

The ends of the core are coated with epoxy resin to ensure they are flat and parallel. The sample is then subjected to compressive tests. The shape, proportions, size, and height-to-diameter ratio of the sample all affect the strength results. For more reliable evaluation, typically more than three samples are taken from different elements of the structure.

### **a-2) Advantages and Disadvantages**

The core testing method using the rotary tool is the most reliable test for determining the mechanical properties of concrete in existing structures. However, this process is costly and faces some challenges. Extracting from structural members, especially vertical ones like columns, samples which are crucial under seismic loading, must be done without compromising the structural capacity of these members.



**Figure 2.3.** Concrete specimen after and before testing.

### **b) Rebound Hammer Test (non-destructive tests)**

Also known as the Schmidt Hammer Test, it is the most common method for assessing the compressive strength of concrete without destroying it. It measures the hardness of the exposed concrete surface. The results obtained can be verified using destructive testing methods for greater accuracy. Below is a detailed overview of the process and considerations related to the rebound hammer test:

### **b-1) Description of method**

The rebound hammer consists of a spring-controlled hammer that slides on a plunger within a tube. When the plunger is pressed against the concrete surface, the hammer strikes the surface with a fixed amount of energy. The rebound distance of the hammer is measured, which is called the rebound number or rebound index, indicating the surface hardness of the concrete.



**Figure 2.4** Rebound Hammer.

To perform the test, the surface on which the test will be conducted must first be cleaned. Any plaster or loose materials in the area should be removed. The plunger of the rebound hammer is then pressed perpendicularly to the concrete surface. The hammer strikes the surface, and the rebound distance is measured. The measured rebound distance is read on the hammer's scale, providing the rebound number, which is related to the surface hardness.



**Figure 2.5** Test Procedures of Rebound Hammer.

### **b-2) Advantages and Limitations of Rebound Hammer testing**

The rebound hammer test is characterized by its simplicity, speed, effectiveness, and low cost. It requires minimal surface preparation, provides immediate results, and is non-destructive. However, the results obtained can be influenced by external factors unrelated to the compressive strength of the concrete. Therefore, in most cases, the results should be calibrated with destructive tests to obtain an accurate assessment of the compressive strength.

### **c) Ultrasonic Pulse Velocity (UPV) Testing (Non-Destructive)**

Ultrasonic Pulse Velocity (UPV) testing is a non-destructive method used to assess the quality and strength of concrete by measuring the speed of an ultrasonic pulse through the material. Here is an overview of the UPV testing process and its applications:

#### **c-1) Ultrasonic Pulse Velocity (UPV) Description**

The UPV device consists of a pulse generator and a pulse receiver. The pulse generator emits an ultrasonic pulse, and the receiver measures the time it takes for the pulse to travel through the concrete. The pulse generated by the pulse generator is typically produced by an electro-acoustic transducer system operating at a frequency range of 50-54 kHz.



**Figure 2.6.** Ultrasonic Pulse Velocity (UPV).

There are three positions for measuring the ultrasonic pulse velocity in concrete using the UPV device:

- **Direct Transmission:** If the concrete element is accessible from two opposite sides, the device's probes (pulse generator and receiver) are placed on opposite and facing directions, as shown in Figure 2.7 a. This is the best position for measuring pulse velocity.
  - **Semi-Direct Transmission:** the concrete element is accessible from two perpendicular sides, the pulse generator and receiver are placed at right angles to each other, as shown in Figure 2.7. b
  - **Indirect (Surface) Transmission:** If the concrete element is only accessible from one side, the device probes are placed on the same surface, as shown in Figure 2.7. c, the result in this case is less reliable.
- In all cases, paths that avoid reinforcement bars should be chosen, as reinforcement can affect the pulse velocity.

After positioning the device on the concrete element, the pulse travel time is recorded. The pulse velocity is calculated by dividing the distance between the transducers by the travel time. Higher pulse velocities indicate higher modulus of elasticity, better strength, and density of the concrete. Lower velocities suggest the presence of cracks and voids within the concrete.



(a)



(b)



(c)

**Figure 2.7.** Test Procedure of Ultrasonic Pulse Velocity,(a) Direct Transmission,(b) Semi-Direct Transmission, and (c) Indirect (Surface) Transmission.

### 2.3. Structural modeling of the existing building

To conduct the inspection and evaluation of the reinforced concrete structure, we examine the building identify its complete configuration, and determine all the characteristics of the structure, concrete, and reinforcement using tools and equipment such as Ultrasound pulse velocity test and Rebound hammer. Then, the structure is modeled using a software like **Seismobuild**, which is one of the engineering programs specialized in assessing RC buildings against seismic loads.

Hence, this section focuses on the following subjects:

- 1- Methods of Analyses
- 2- Modelling of RC Structures
- 3- Checks and Acceptance Criteria

4- Modeling steps using SeismoBuild software.

### 2.3.1. Methods of Analyses

Performance-Based Engineering (PBE) is a relatively recent concept, introduced approximately 20-25 years ago, and has since been incorporated into all modern structural codes. Unlike traditional design practices that typically focus on a single performance level—often Collapse Prevention with limited requirements and some additional clauses for the Serviceability Limit State—PBE emphasizes the necessity for multiple performance levels.

Within this context of Performance Based Engineering (PBE), 4 different analytical methods are proposed by all modern Codes with very small variations between them:

- Linear Static Procedure LSP, a static type of analysis with no variable load
- Linear Dynamic Procedure LDP, which is essentially the Response Spectrum Method (RSA)
- Nonlinear Static Procedure NSP, which is the well-know Pushover Analysis, either in conventional or adaptive mode
- Nonlinear Dynamic Procedure NDP, which is the nonlinear dynamic time-history analysis.

The nonlinear methods of analysis, being numerically more advanced, are considered to be more accurate in the representation of the dynamic loading, since they consider the concentration of damage at the weakest locations of the building and the redistribution of forces upon the formation of plastic hinges. Furthermore, the dynamic methods are considered to represent better the dynamic nature of seismic loading with respect to their linear counterparts.

Recognizing the different levels of sophistication of the different methods, all Codes impose limitations in the use of the simpler methods. The general concept is that simple methods can only represent with sufficient approximation the structural behaviour of equally simple buildings. As shown in the table below, only the Nonlinear Dynamic Procedure can be used for any type of building and any type of loading. On the contrary, the Nonlinear Static Procedure cannot handle more complex seismic loading and higher mode effects, since the entire theoretical background of pushover analysis is based the fact that the structure vibrates according to the fundamental mode only. Similarly, the Linear Dynamic Procedure cannot handle cases, where large inelasticities are expected, whilst the Linear Static Procedure, being very simplistic, can be accepted only in cases of very regular, low-rise buildings.

**Table 2.1:** Limitations in the use of the different analysis methods [12].

Analysis Procedure	Structural irregularity	High Inelastic Demand	Higher mode effects	Near source earthquakes
LSP	✗	✗	✗	✗
LDP	✓	✗	✓	✗
NSP	✓	✓	✗	✗
NDP	✓	✓	✓	✓

In the vast majority of existing buildings, especially those which have been built in the 70s or before without explicit seismic provisions. Such buildings have significant irregularities in plan and in elevation, and they are expected to experience serious damage in the design earthquake with significant inelastic deformations at specific parts of the building (e.g. weak ground storey). Because those buildings are the ones that require more the assessment of their seismic response and strengthening, the nonlinear methods have become the ‘standard’ methods for this purpose. In particular, the NSP and pushover analysis are gradually becoming the 'standard' methodology for assessment and retrofit, because of the simplicity in its application.

**a) Pushover analysis**

The pushover analysis is a non-linear static analysis aimed at evaluation the performance of the building structure against seismic loads. The analysis considers seismic loads on buildings as constant and increasing horizontal loads applied at the center of mass on each floor. The constant loads gradually increases, causing the material in one structural element to deform because it has exceeded the material’s elastic limit, surpassing the first limit of building. This bending is followed by bending in other elements of the building structure.

Adding the constant loads stops when the buildings structure reaches bending or deflection. Through this analyses, a non-linear static capacity curve is obtained, which will be processed later.

The pushover analysis method relies on three main steps:

**a-1) Capacity curve**

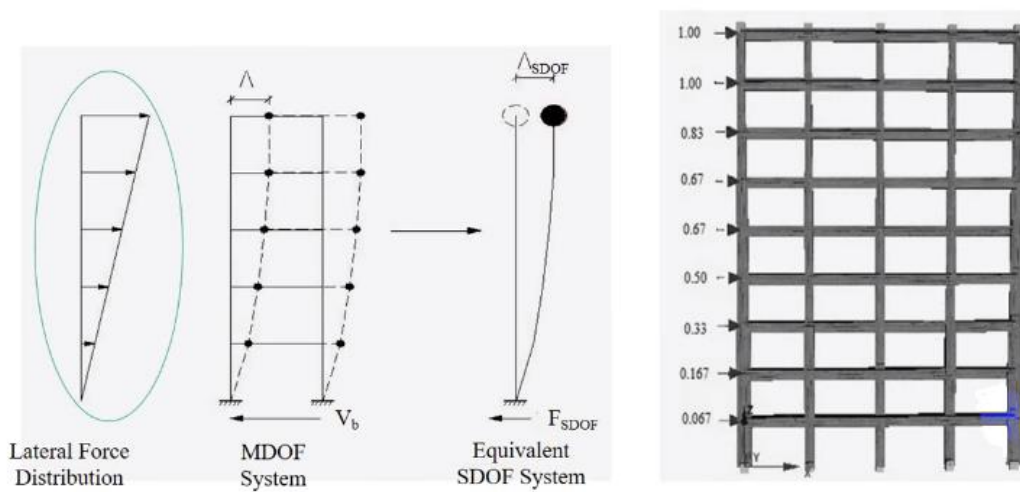
It represents the structure’s ability to resist seismic demand. The capacity curve is derived from the relationship between base shear and roof displacement, as illustrated in **figure 2.8**.

Here is an explanation of the steps to accomplish the capacity curve:

1. Classifying all structural elements into primary or secondary elements and define hinges properties.
2. Applying horizontal lateral forces on each floor proportional to mass and vibration pattern coordinates, the applied lateral force can take the form of an inverted triangle. The distribution of these forces varies according to:

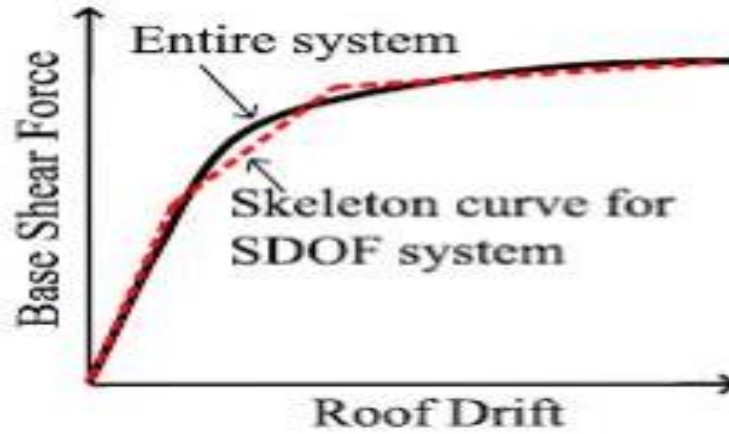
$$F_i = \frac{m_i h_i}{\sum_{i=1}^n m_i h_i} V_b \quad 2.1$$

Where  $h_i$  is the height of the first floor.  $m_i$  is the mass of the  $i$ th floor,  $V_b$  is the shear force at the base and  $n$  is the total number of floors.



**Figure 2.8** The force takes the form of an inverted triangle [17].

3. Continuing to apply incremental increases in horizontal forces until a structural element or group of elements reaches its ultimate deformation state, indicating that the element is no longer capable of withstanding further horizontal forces.
4. Recording base shear forces and roof displacements in each analysis process.
5. Constructing a pushover curve for the structure based on base shear forces and roof displacements.



**Figure 2.9** The pushover curve in SDOF system [18].

6. For matching the capacity curve with the demand curve, It is necessary to convert the base shear forces  $V$  (KN) into spectral acceleration  $S_a$ (g) using the following equation:

$$S_a = \frac{V/W}{\alpha_1} \quad 2.2$$

$V$ : is the base shear.

$W$ : is the building dead load plus likely live loads.

$\alpha_1$ : is the modal mass coefficient for the first natural mode.

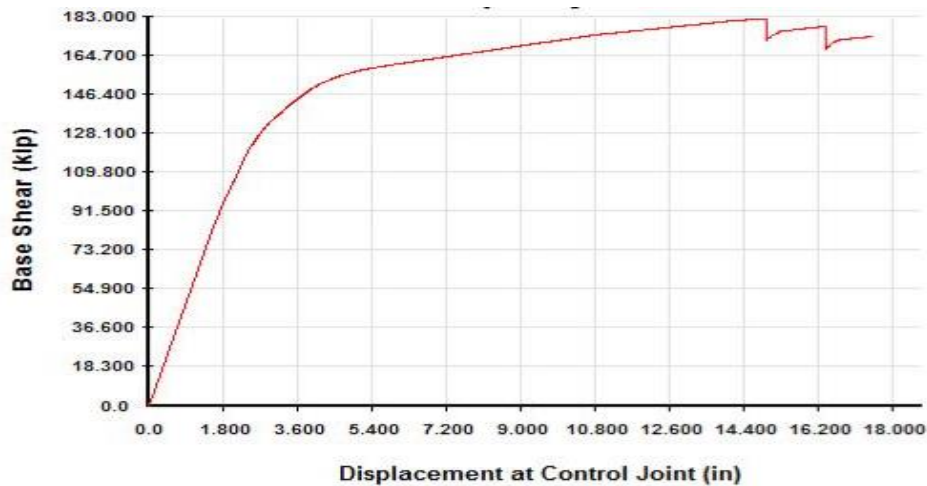
And converting roof displacements  $\Delta_{\text{roof}}$  (m) into spectral displacement  $S_d$  (m) using the following equation:

$$S_d = \frac{\Delta_{\text{roof}}}{PF_1 \phi_{i1}} \quad 2.3$$

$\Delta_{\text{roof}}$ : is the roof displacement.

$PF_1$ : is the modal participation factor for the first natural mode.

$\phi_{i1}$ : is the amplitude of mode 1 at level 1.

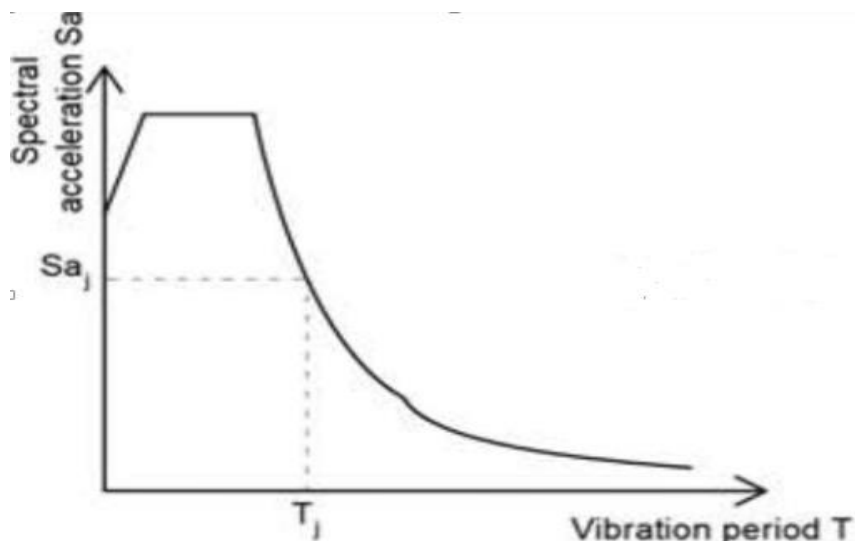


**Figure 2.10** The capacity curve (MDOF system) [18].

### a-2) Demand curve

The demand curve is a representation of seismic ground motion, expressing the expected maximum response during an earthquake. This is achieved by transforming the **Elastic Response Spectrum** into the **Demand Curve** to match the demand curve with the capacity curve.

- **Elastic Response Spectrum:** it is graphical representation (Figure 2.11) of the maximum structural response of a building (**Spectral Acceleration ( $S_a$ )**) against **Time period ( $T$ )**, based on location, soil type, and design codes such as ASCE7 [19] or Eurocode 8 [20].



**Figure 2.11.** Elastic Response Spectrum (MDOF system) [21].

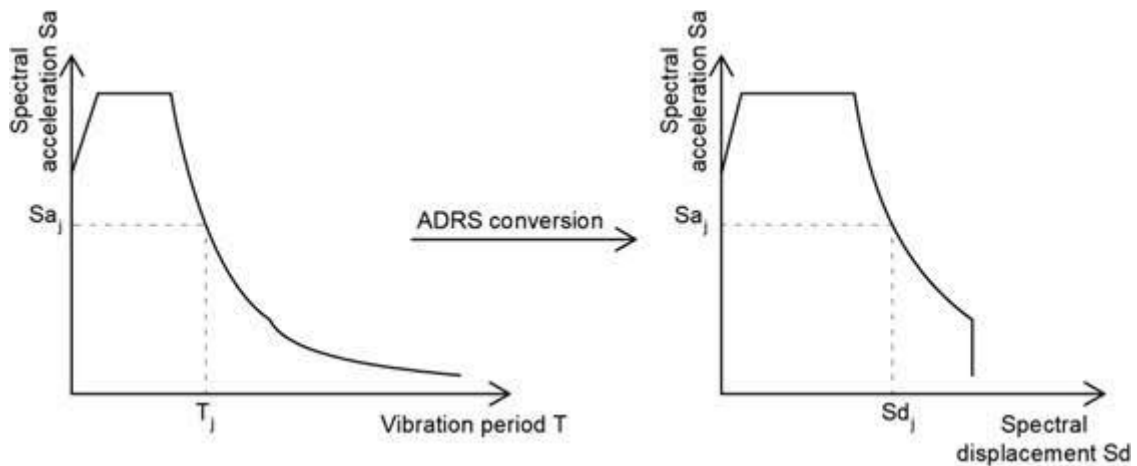
- **Transforming the Elastic Response Spectrum into the Demand Curve:** to convert the Elastic Response Spectrum into the Demand Curve for matching the demand curve with the capacity curve, using the following equation:

$$S_d = \frac{T^2}{4\pi^2} S_a \quad 2.4$$

$S_d$ : The spectral displacement.

$T$ : The Time period.

$S_a$ : The spectral acceleration.



**Figure 2.12** Transforming the Elastic Response Spectrum into the Demand Curve [21].

### a-3) Performance point

This point represents a state where the seismic capacity of the structure equals the seismic demand imposed on it. After determining the demand curve and defining the capacity curve, the demand curve is matched with the capacity curve to estimate the maximum potential ground motion for assessing the building structure's performance. To determine the performance point, the following conditions must be met:

- The point must lie on the capacity spectrum curve.
- The demand curve must be reduced by a reduction factor due to effective damping.

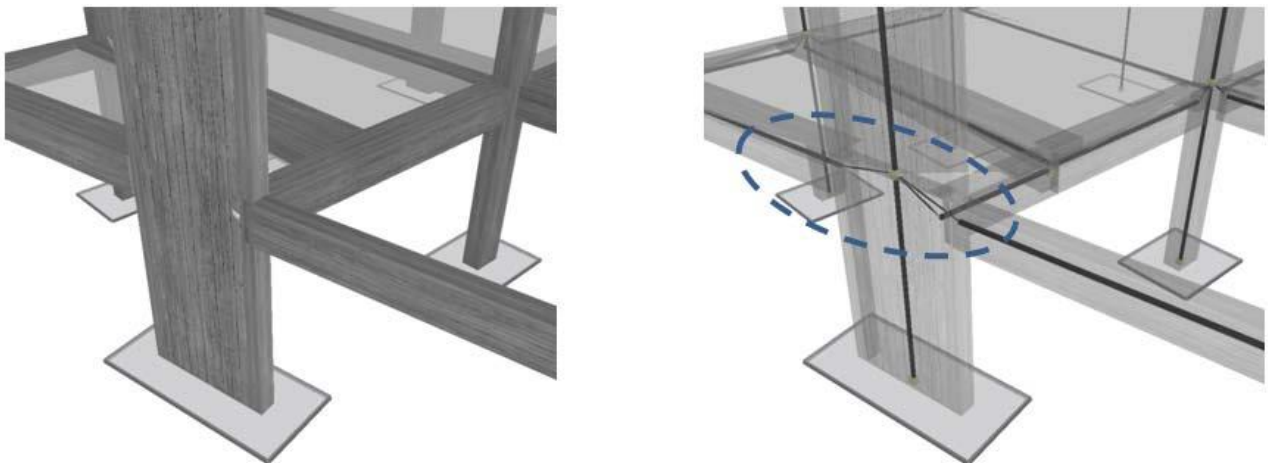




**Figure 2.14.** Element section modeling [12].

### b) Modelling of shear walls

Large shear walls are modelled with four-node bidirectional elements (Shell or Plate Elements) in structural analysis. Members may be subdivided into smaller elements for increased accuracy, especially if software provides automated N, V, and M results. However, professional software usually only offers linear modelling for plane elements, inadequate for nonlinear assessments. Damage is often expected at the base of shear walls, making elastic plane elements unsuitable. Therefore, equivalent nonlinear 1D elements are necessary, using horizontal rigid links to connect wall nodes to adjacent beams.



**Figure 2.15.** Shear wall modelling with rigid offsets [12].

### **c) Modelling of slabs**

In seismic assessments, gravity loading is secondary, as earthquakes are typically the most demanding. Slabs are not directly affected by seismic loads; they transfer loads to beams, columns, and walls, acting as diaphragms. Modern slabs are designed to be rigid diaphragms, but existing buildings may have rigid or flexible slabs. Rigid diaphragms are modelled with special links, while flexible slabs are discretized into smaller elastic plate elements.

### **d) Modelling of beam-column joints**

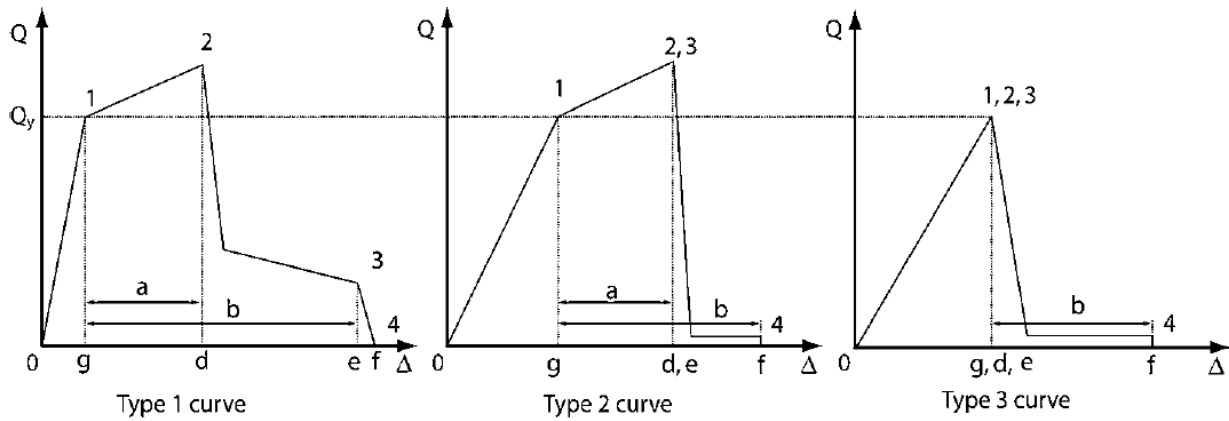
Beam-column joints in existing buildings often suffer from inadequate reinforcement and lap splices, leading to a response that is neither rigid nor elastic. Advanced modelling, using special inelastic elements or elastic/inelastic link elements, can more accurately represent the structural response. However, these advanced methods are challenging to apply despite their accuracy.

### **2.3.3. Checks and Acceptance Criteria**

According to ASCE 41-17 [20], a Component is a part of a building's architectural, mechanical, electrical, or structural system, such as beams, columns, and diaphragms. The mechanical properties and interconnections of these components are investigated during analytical procedures. Components are classified as primary or secondary. Primary components are those required to resist seismic forces and accommodate deformations to achieve the selected Performance Level. Secondary components accommodate seismic deformations but are not required to resist seismic forces. This classification allows flexibility in the evaluation and retrofit process. Secondary components include non-structural elements that do not significantly contribute to earthquake resistance, structural components that are not reliable for resisting earthquake effects, or primary components deformed beyond their useful limits.

#### **a) Deformation-controlled & force-controlled actions**

All actions are classified as either deformation-controlled or force-controlled. Deformation-controlled actions have ductile failure mechanisms and perform well in the inelastic range, with force vs. deformation curves similar to Type 1 in Figure 2.16. Force-controlled actions have brittle failure mechanisms, with curves similar to Type 3. Type 2 curves describe behaviors between full deformation or force control. The classification is specified by codes, not the engineer's discretion. For example, beam flexural behavior is deformation-controlled, while shear behavior is force-controlled. Each component must be evaluated for both types of actions, as specified by codes. Engineers must check all components, not just those deemed important based on judgment.



**Figure 2.16.** Component Force vs. Deformation Curves [22].

### b) Capacité check

As in standard design methodologies, the capacity checks are carried out so that the component Strength  $Q_C$  is larger than the Demand on the component  $Q_U$ . One important variation with respect to the design procedures however is that for the deformation-controlled actions (e.g. bending) the mean or expected strengths of the members is employed, rather than the characteristic or lower-bound strength. For the force-controlled actions instead (e.g. shear) the characteristic or lower-bound strengths of the components is used.

### c) Main Checks to be carried out in an Assessment Procedure

#### c-1) Shear Checks

This is the most common, the most important and typically the most critical check that is carried out in the assessment methodologies. The reason why it is the most critical check is mainly because of the significant lack of transverse reinforcement in older constructions. For the components with low ductility demands, the shear strengths are calculated following the procedures for effective elastic response for the typical shear design

#### c-2) Bending Checks

This is a deformation-controlled action and the checks in bending in the nonlinear procedures are carried out in terms of deformations. In the general case, the plastic hinge rotation is selected as the quantity to be checked, with the exception of large RC walls that are controlled by shear, in which case the checks are carried out in terms of the lateral drift ratio.

### ***c-3) Beam-Column Joints***

This is a force-controlled action and the checks are carried out in terms forces, typically in terms of the joint shear strength. It is noted that in ASCE 41 explicit rules on how to model the flexibility and nonlinear behaviour of the beam-column joints are also provided.

#### **2.3.4. Modeling steps using SeismoBuild software.**

SeismoBuild is an engineering software developed by Seismosoft for evaluating and strengthening RC structures against seismic loads [23]. It's the only fully compliant engineering program worldwide for structural assessment and strengthening.

The SeismoBuild can be execute all assessment methodologies specified by international codes, currently supporting six codes: Eurocodes [20], American code for seismic Evaluation and Retrofit of Existing buildings ASCE 41-17 [22], Italian National Seismic Code NTC-18 & NTC-08 [24], Greek Seismic Intervention Code KANEPE [25], and Turkish Seismic Evaluation Code TBDY [26]. Additionally, it can model structures using four seismic analysis methods: Equivalent static analyses, Response spectrum analyses, nonlinear dynamic analysis, and pushover analyses. And it supports both American and European rebar types, as well as metric and imperial units.

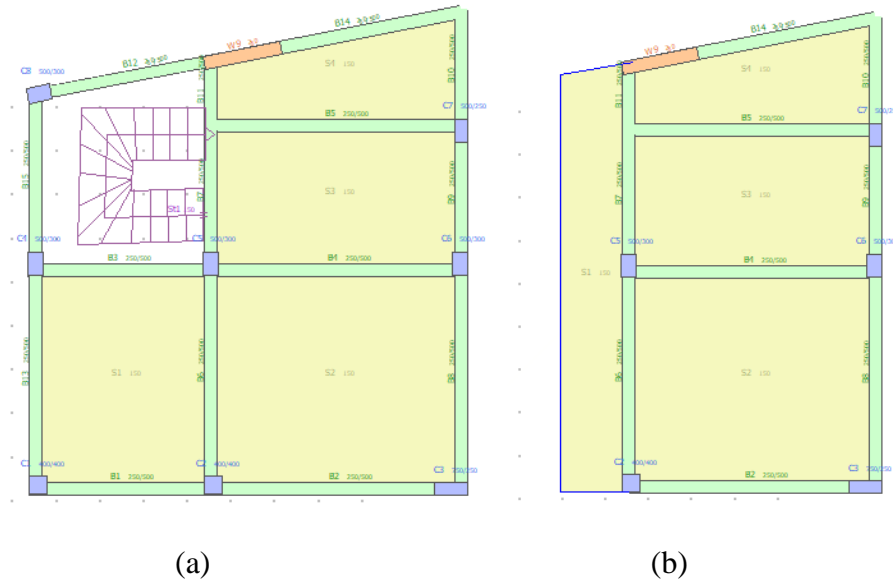
SeismoBuild is designed to be user-friendly, requiring no additional file input during usage, and capable of modeling RC structures in true 3D.

#### **a) Structure modelling in SeismoBuild**

To model a reinforced concrete building structure in Sismobuild, we start by inserting all columns and beams with their dimensions using a CAD drawing import for the background to facilitate defining the structural elements' geometry. Then, we can browse the results of structural element inspections in the inspection area. We can explain the process of modeling a reinforced concrete structure in the following steps:

##### **a-1) Building modeling**

To model a reinforced concrete structure, we first import the building layout as a CAD drawing into the background to facilitate defining the structural elements of the building. Then, all structural elements of the structure (columns, beams, reinforced concrete walls, roof, stairs, etc.) are defined, along with assigning concrete type and reinforcement. This process is depicted in **Figure 2.17**.

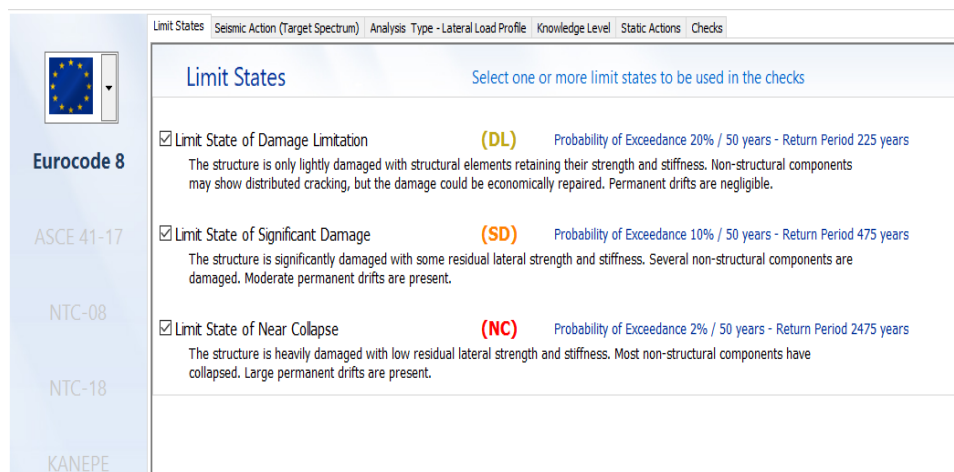


**Figure 2.17** Building Modeler, a) 1st Floor, b) 2nd Floor.

### a-2) Code requirements

Through this stage, it's possible to define the necessary information for structural assessment. The information is defined as follows:

- Allowing the assignment of limit states available in the seismic code.



**Figure 2.18** limit states available in the seismic code.

- Choose the Nonlinear Static Analysis method, which is the most simplified/accurate for seismic assessment, and select basic load patterns.

- Select the level of knowledge about the structure and confidence factor.

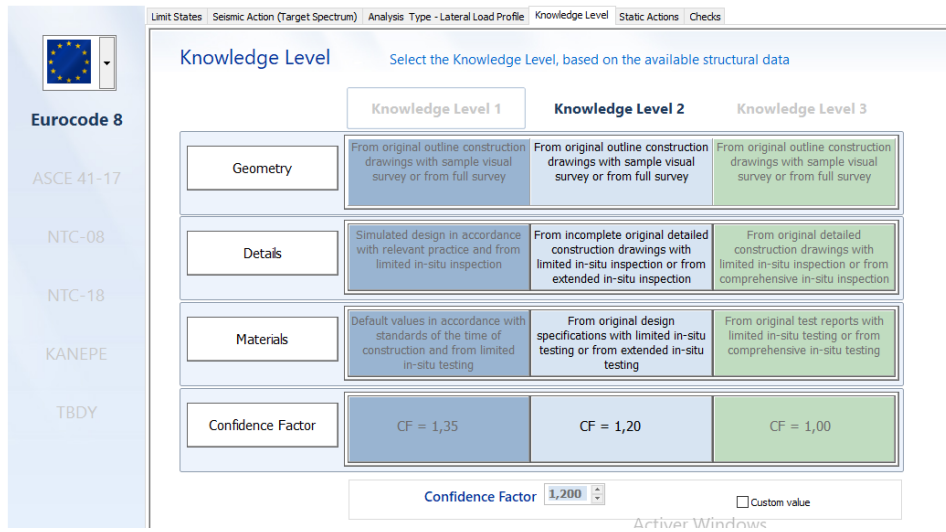


Figure 2.19 knowledge level window.

- Define the used response spectrum type, ground type, and seismic importance class for the building.

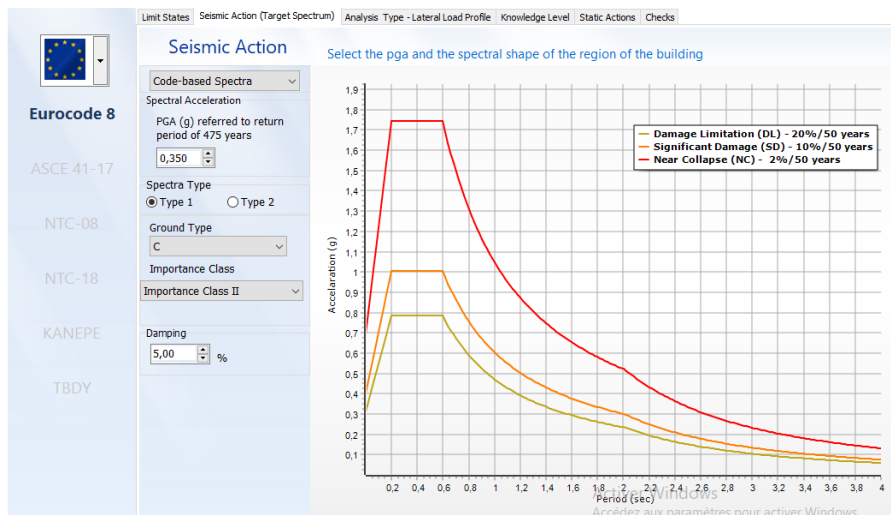
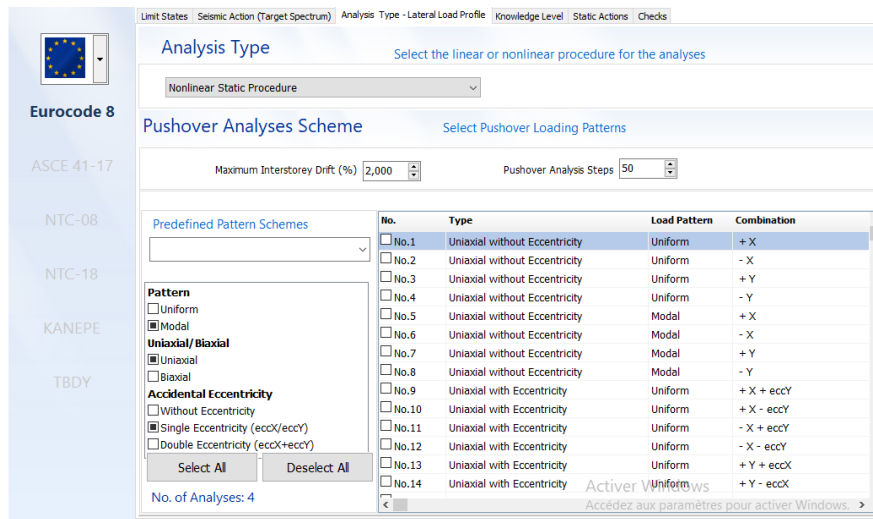


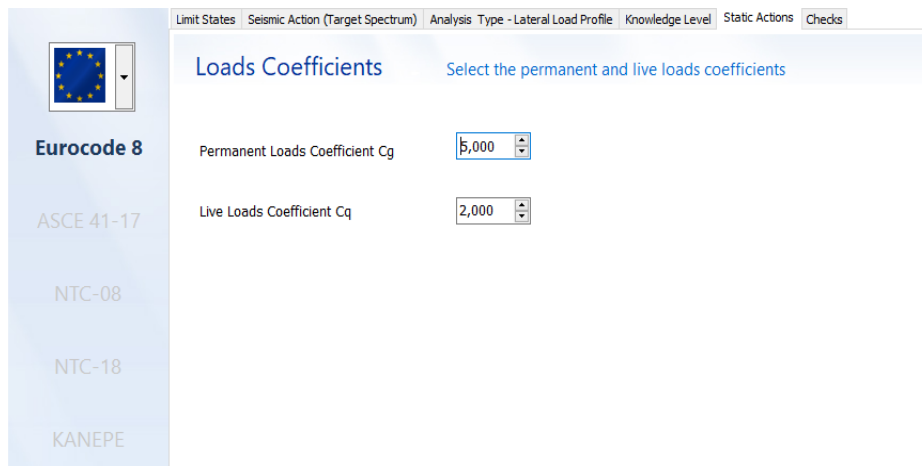
Figure 2.20 seismic action window.

- Carefully selecting the axes we want to analyze is crucial for obtaining accurate and meaningful results.



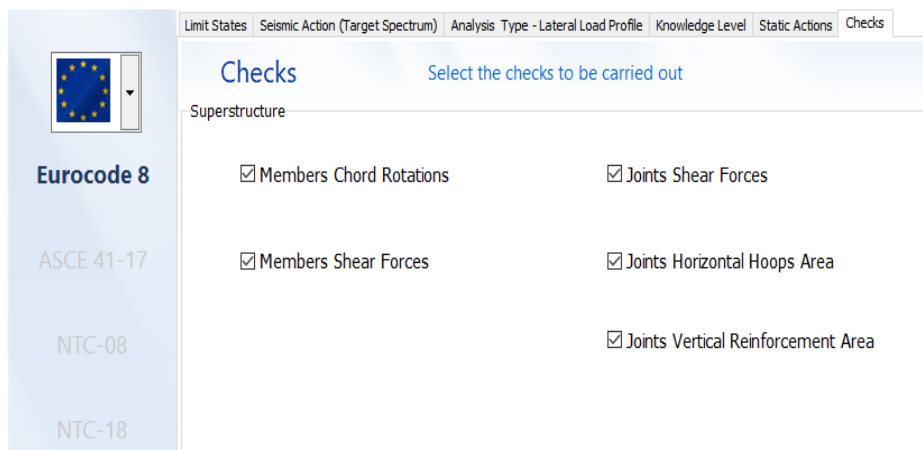
**Figure 2.21** Analyses types window.

- Set the values of dead load and live load coefficients for the structure.



**Figure 2.22** Set the values of dead load and live load for the structure.

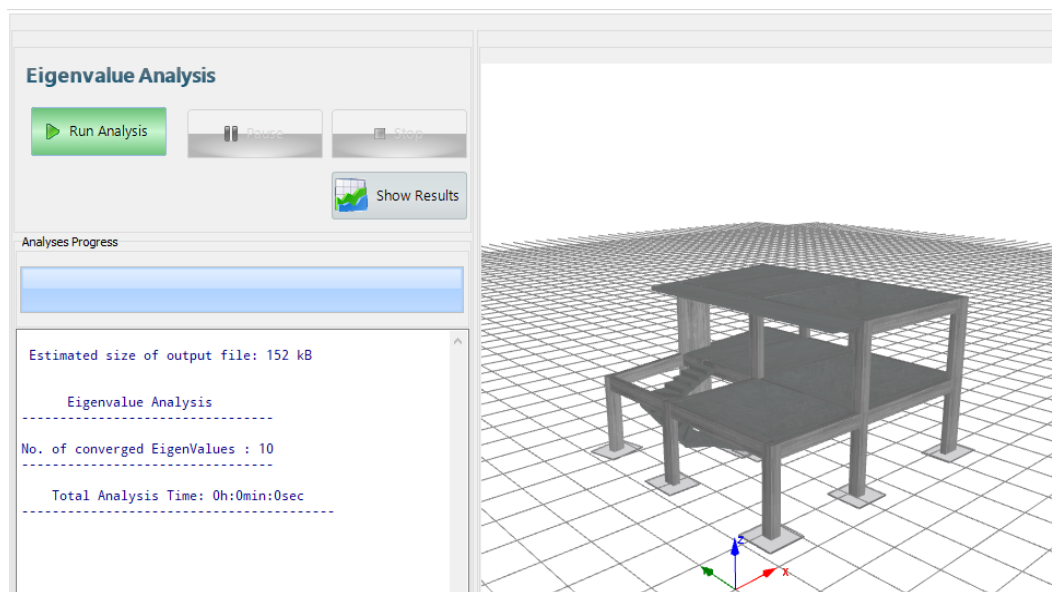
- Then, specify all inspections we want to conduct on the structure.



**Figure 2.23** specify the inspections we want to conduct on the structure.

### a-3) Eigenvalue analysis

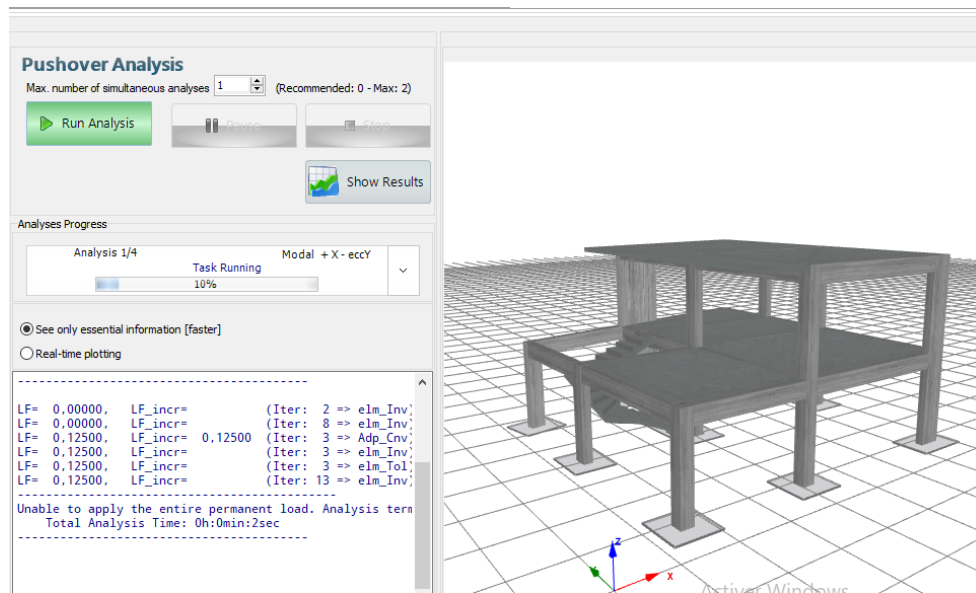
We run the eigenvalue analysis and show results, where the building's natural frequency and mass are displayed.



**Figure 2.24** Eigenvalue analysis window.

### a-4) Pushover analysis

The Rayleigh damping curve can be obtained and the structural performance under seismic loads can be assessed by clicking on the "Run Analysis" button, then clicking on "show Results".



**Figure 2.25** Eigenvalue analysis window.

#### a-5) Checks

The results of structural element inspections in the inspection area can be browsed in the form of a table or diagram. They can then be copied to the Excel application. We can identify the limit state of the elements where those exceeding the maximum demands are displayed in red in both the table and the three-dimensional figure.

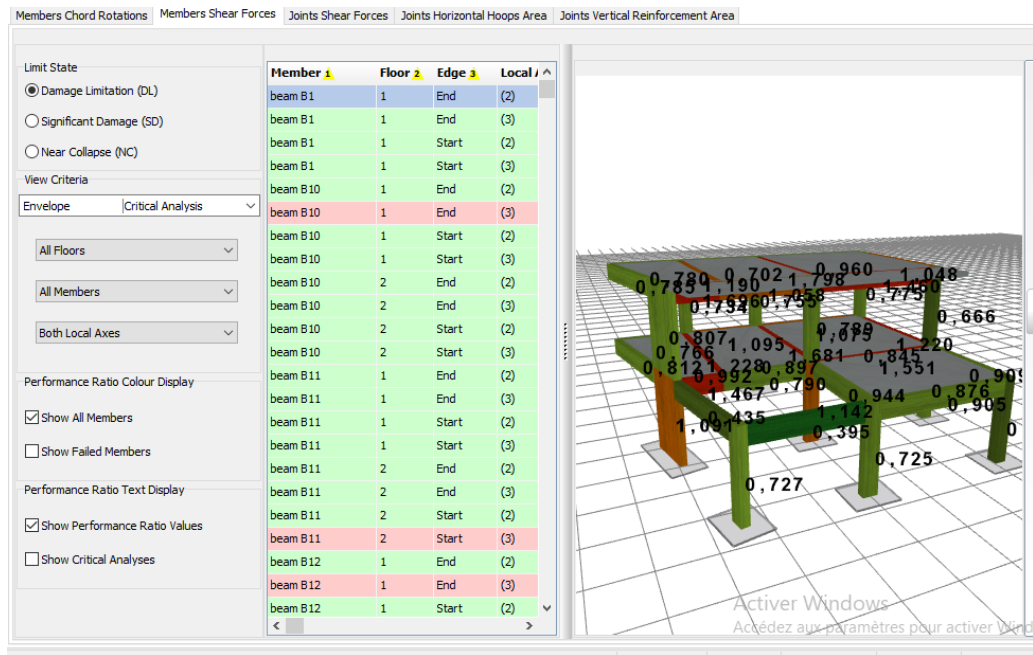


Figure 2.26 Checks Module (Member Shear Forces).

## a-6) Rapport

A report on the building inspection results can be generated by clicking on "Report," where the performance of the building structure is detailed and explained.

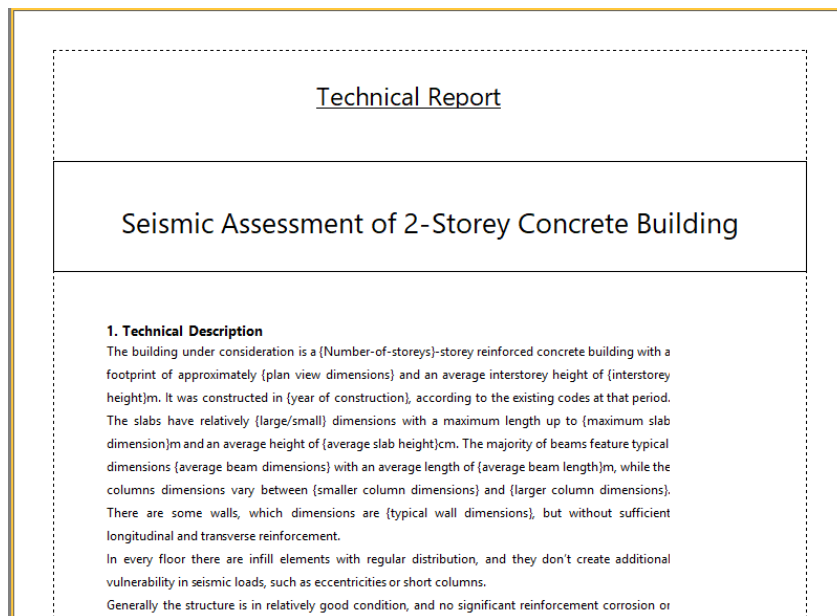


Figure 2.27 Technical Report.

---

## **2.4. Conclusion**

Effectively assessing buildings for seismic loads requires a deep understanding of the method for inspecting reinforced concrete structures, implementing non-linear analysis methods, and modeling structures in software like "SeismoBuild." Non-linear analysis involves using complex mathematical models to represent the non-linear behavior of structures during earthquakes, allowing for more accurate and realistic analysis. "SeismoBuild" is a powerful tool for modeling and analyzing buildings comprehensively, aiding in enhancing their safety and effectively increasing their seismic resilience.

## **Chapter 03**

# **Techniques of strengthening of existing buildings**

### **3.1 Introduction**

Before the establishment of international seismic codes that include the standards necessary for earthquake-resistant construction, the buildings were designed to resist gravity and the building's own weight, with low seismic specifications. As a result, there are many old buildings that were damaged because their ability to withstand the earthquake is very weak compared to modern standards, and they are often in dire need of reinforcement.

The distinction between the concept of rehabilitation and the concept of reform is very important, as the concept of reform to damaged building, but rehabilitation does not necessarily relate to damaged buildings, it is procedure used by engineers to strengthen existing building to resist earthquakes in the future.

### **3.2 Strengthening Techniques for the Retrofit of RC Buildings**

Strengthening Techniques for the Retrofit of RC Buildings" involves methods to enhance the structural integrity and performance of reinforced concrete (RC) buildings. These techniques are essential for improving the resilience of existing structures against seismic activities, environmental degradation, and increased load demands. Common methods include the use of fiber-reinforced polymers (FRP), steel jacketing, and concrete jackets. The goal is to extend the lifespan of buildings while ensuring safety and compliance with updated building codes. This field combines principles of structural engineering, materials science, and construction practices to achieve optimal retrofit solutions.

In the next sections, we present the most common techniques used to strengthen RC buildings

#### **3.2.1 Reinforced concrete jackets**

Concrete jacketing is the most common technique for strengthening reinforced concrete (RC) members. It involves adding a layer of reinforced concrete around the existing structural members with additional longitudinal and transverse steel reinforcements. Cast-in-place concrete or shotcrete is used for concrete jacketing.



**Figure 3.1.** Reinforced concrete jackets [8].

#### **a) Cast-in-place concrete jacketing**

For cast-in-place concrete jacketing, forms are installed around the existing column to support the new concrete. The jacket thickness is usually more than 10 cm to facilitate the concrete pouring process.

#### **b) Shotcrete jacketing**

Shotcrete jacketing is flexible in shape (Figure 3.2), adheres well to the existing member, and offers high strength and durability. It is suitable for jacketing areas that are difficult to access. The thickness of shotcrete jacketing is typically more than 7.5 cm, but it can be as thin as 5 cm in some cases. There are two types of shotcrete:

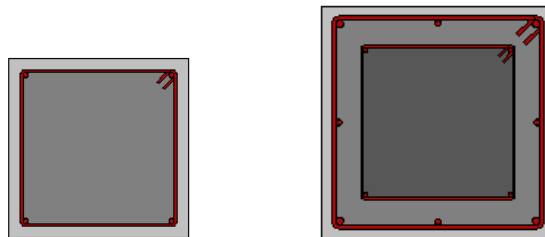
- Dry-mix shotcrete, where cement and aggregate are mixed on-site, and water is added during spraying.
- Wet-mix shotcrete, where pre-mixed concrete is pumped and sprayed.



**Figure 3.2** Shotcrete jacketing [27].

### c) Method of applying reinforced concrete jacketing

To ensure good adhesion between the jacket and the column, the surface of the column first prepared by cleaning it thoroughly and ensuring its integrity. Then, the surface roughened and steel dowels used to connect the column to the jacket. The vertical and horizontal steel bars and stirrups should be installed as per the design.



**Figure 3.3** reinforcement of RC jacketing.

### d) Advantages of reinforced concrete jacketing

The method of reinforced concrete jacketing is widely used to enhance a structure's ability to withstand seismic loads. It significantly increases the strength, flexibility, and stiffness of the existing members. Additionally, since reinforced concrete jacketing increases the cross-sectional dimensions, it may reduce the seismic demand on untreated members.

### 3.2.2 New shear walls

Adding new shear walls significantly enhance the seismic performance of existing buildings by providing increased strength, stiffness, and ductility. These walls are much stiffer than many existing vertical elements. To avoid torsional effects and vertical irregularities, shear walls added along the length of the building in a similar manner.



**Figure 3.4** application of New shear walls [27].

#### a) Method of installing shear walls

To install new shear walls, they connected to existing columns to form new composite columns. To transfer inertial forces to the new walls, there must be a strong connection between the new and existing walls, achieved by cleaning the surface of the existing reinforced concrete and installing numerous steel dowels for adhesion. Reinforced concrete (RC) walls installed either externally around the building's perimeter or internally within the building's bays.

#### b) Advantages of new shear walls

One advantage of new shear walls is that they reduce the seismic demand on all existing vertical elements, as they can bear 70-80% of the base shear forces due to their high stiffness. Therefore, reinforcing a building with shear walls may allow reducing intervention points and costs.

### c) Disadvantages of new shear walls

Despite the advantages of new shear walls, there can be significant challenges in finding suitable locations for their installation. The new walls must not block openings such as doors and windows and should be symmetrically positioned to prevent torsional effects.

### 3.2.3 Steel bracing

Structures are reinforced using steel braces to increase the strength, stiffness, and flexibility of buildings. This technique involves installing steel braces within the building openings to improve its resistance to lateral forces. The resisting force is generated through the axial forces in the inclined brace members. Steel plates are fixed at the corners of the reinforced concrete building openings using epoxy resins, with specially designed configurations for the foundations at ground level.



Figure 3.5 Steel bracing [28].

### a) Types of Steel Bracing Systems

Steel bracing systems vary based on their shape and installation method, including:

#### ❖ Concentric Bracing Systems (CBS)

This is the most common technique for retrofitting reinforced concrete frames. It includes:

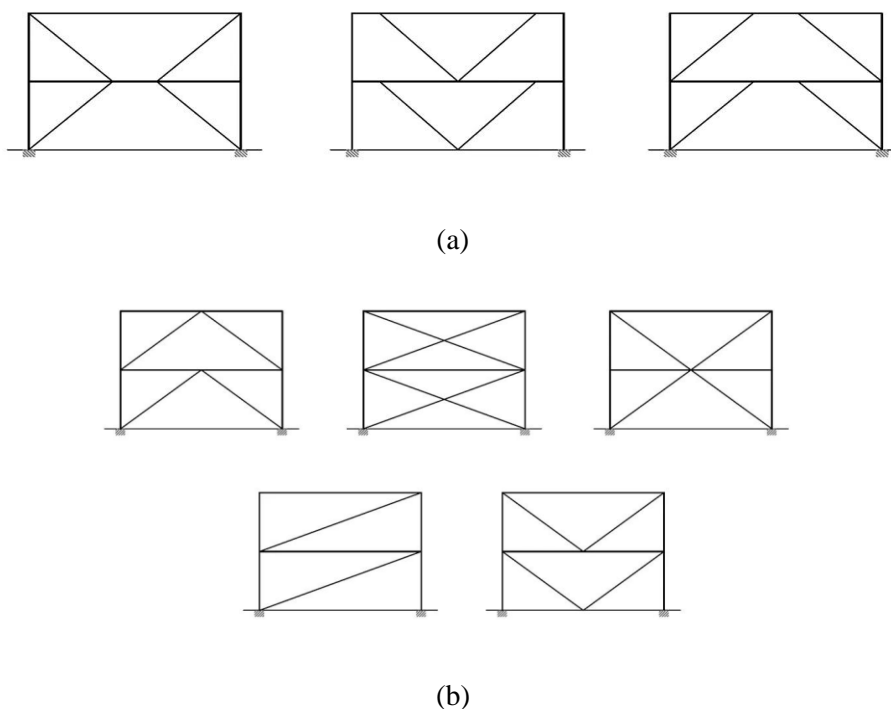
- Cross braces (X-braces) Installed with diagonals extending in both directions within the opening, forming an X shape.
- Single diagonal braces one diagonal brace per opening.

- V-braces or inverted V-braces (Chevron braces) installed so that the inclined braces connect at the midpoint of the horizontal member of the opening. This technique is less common.
- K-braces generally not allowed due to the high inelastic demand on the columns.

#### ❖ Eccentric Bracing Systems (EBS)

A less common technique designed to allow some flexibility and energy dissipation during earthquakes.

Can be constructed around the building perimeter and connected to the existing frame system using large steel connections to transfer seismic loads to the ground.



**Figure 3.6** Typical (a) Eccentric Bracing Systems and (b) Eccentric Steel Braces Systems in retrofit [12].

#### b) Advantages of Steel Braces

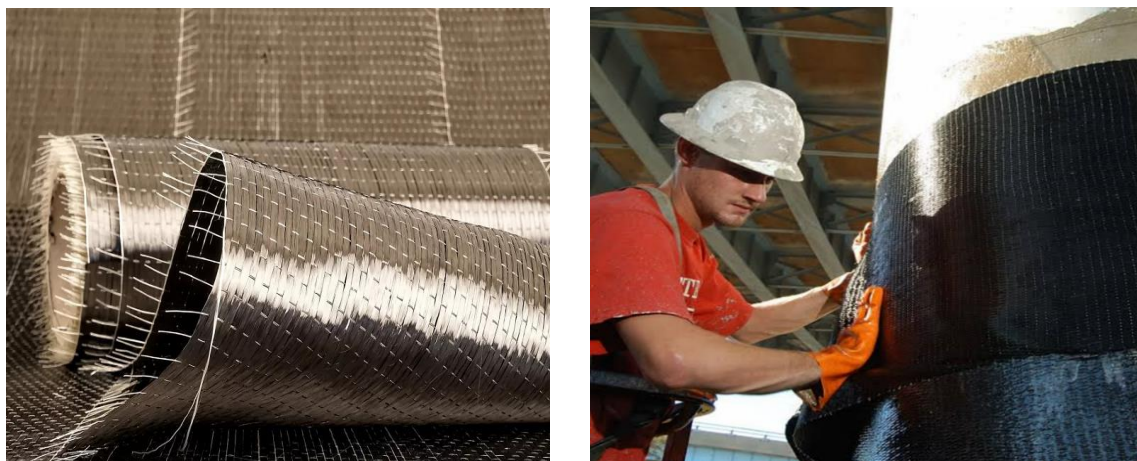
Steel braces increase shear strength and stiffness similarly to reinforced concrete shear walls, enhancing the building's capacity to resist lateral forces. They add little weight to the building structure due to their light weight. Steel braces can adapt to existing openings, making them versatile. Unlike concrete shear walls, steel braces do not require additional concrete during installation, reducing dust and debris, which is beneficial for occupied buildings. They are ideal for reinforcing soft ground floors without causing significant disruption.

### c) Disadvantages of Steel Braces

One of the main disadvantages of steel braces is the difficulty in finding suitable locations or openings for installing the braces and ensuring symmetrical distribution. They may be less effective for buildings with large existing shear walls. Achieving high-quality welding and controlling the interaction between the new steel components and the existing concrete system can be challenging during installation.

### 3.2.4 FRP Wrapping

FRP fibers are composed of carbon, glass, aramid, or sometimes basalt fibers. The polymer matrix is developed using epoxy resins. FRP materials can be widely used to enhance reinforced concrete building elements, improving their shear and bending strength without altering their stiffness or the overall structural rigidity.



**Figure 3.7** FRP Wrapping [14].

### a) Advantages of FRP

FRP fibers have high tensile strength and low weight compared to traditional steel. They save time and effort due to their ease of handling and are resistant to corrosion, making them suitable for harsh environments unlike steel. Additionally, FRP fibers have low thermal conductivity.

### b) Disadvantages of FRP

FRP materials are not fire-resistant, and their structural integrity can deteriorate when exposed to high temperatures. There is also insufficient experimental data on the long-term degradation of the mechanical properties of FRP fibers.

### c) Techniques for Strengthening Structures with FRP

The process of strengthening existing structures with FRP materials can be done through two main methods:

#### ❖ FRP Wrapping

Structural elements of the building are wrapped with FRP sheets to enhance their strength. This method is used to increase the ductility of the structure and improve its shear and bending capacity.

#### ❖ FRP Laminates

FRP Laminates, which are pre-cured and rigid strips or panels, are bonded to the structural elements that need reinforcement. They are used to increase the bending capacity of elements and to enhance shear strength.



**Figure 3.8** application of FRP Laminates [14].

### 3.2.5 Steel Plates

Steel plates used on concrete structural elements to enhance their bending strength, shear strength, and ductility, similar to fiber-reinforced polymer (FRP) wraps. The steel plates fastened to the existing concrete surfaces using steel dowels and epoxy resins. To create steel jackets for encasing reinforced concrete columns, horizontal and vertical steel plates can be welded together.

Steel plates have some disadvantages compared to FRP materials. FRP wraps and sheets are generally easier to handle and install, which has led to a decrease in the use of steel plates for reinforcing existing concrete buildings.



**Figure 3.9** application of Steel Plates [18].

### 3.2.6 Resins and Repair Mortar

Among the essential materials in the maintenance and reinforcement of reinforced concrete structures are epoxy resins and repair mortar, primarily addressing localized damage rather than strengthening the structure as a whole, playing a vital role in repairing individual structural elements.

#### a) Epoxy Resins

Epoxy resins are commonly used to repair cracks through injection. They possess high tensile and compressive strength compared to concrete, ensuring effective stress transfer and restoring structural integrity by strongly adhering to concrete. They can effectively penetrate fine cracks due to their low viscosity, preventing water leakage and thus corrosion of the reinforcement steel. Despite their advantages in repairing localized structural damage, epoxy resins are sensitive to moisture during application, which may hinder their adhesion to reinforced concrete, and they are also susceptible to fire, as exposure to high temperatures can significantly reduce their strength.



**Figure 3.10.** Cracks repair with epoxy resins [30].

### **b) Repair Mortar**

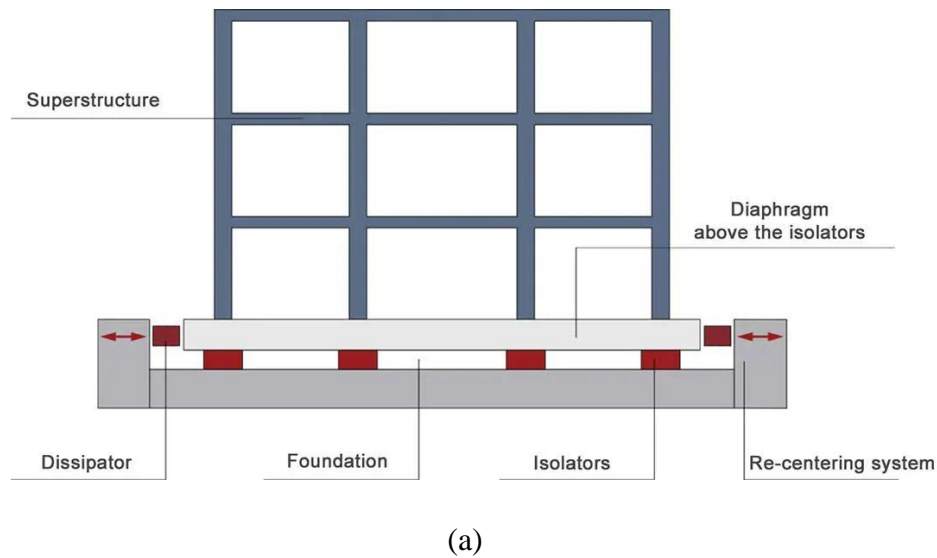
Repair mortar is used to restore and repair damaged concrete sections, characterized by containing corrosion inhibitors to prevent the deterioration of reinforced concrete due to rebar corrosion.



**Figure 3.11.** Repair with corrosion inhibitors and repair mortars [31].

### 3.2.7 Seismic isolation

Seismic isolation systems reduce the impact of earthquake forces on a structure by adding significant flexibility to the building. They are designed to dissipate energy to control displacement within the isolation system. Seismic isolation systems can prevent structural movement by maintaining lateral stiffness against low lateral loads such as wind and minor earthquakes.



**Figure 3.12.** (a) Typical base isolation configuration and (b) the base isolation configuration [12].

#### a) Advantages of Seismic Isolation

Seismic isolation reduces the acceleration transmitted to the superstructure, decreasing inertial forces, lateral deformations, and inter-story drifts. This leads to reduced structural and non-structural damage even during severe earthquakes. Additionally, reinforcement work at the foundation level does

not significantly disrupt building occupants. Damage from major earthquakes can be easily repaired without evacuating the building, as the damage is usually confined to the isolators at the foundation.

### b) Challenges and Considerations

During seismic reinforcement using seismic isolation, we face several challenges, such as cost. Seismic isolation can be a costly solution, especially for small to medium-sized buildings (i.e., under 10 stories), where the cost outweighs the expected benefits. Therefore, this method is primarily used in large buildings. Additionally, designing and constructing base isolation systems require specialized skills, primarily available in large design and construction firms. This makes seismic isolation more suitable for large and significant projects.

## 3.3 Foundation strengthening

Strengthening foundations is a multifaceted challenge, requiring extensive expertise in various fields such as soil mechanics, foundation engineering, and structural dynamics. Due to the technical complexity and cost of such interventions, justifying them becomes necessary only in cases of significant deficiency, such as the absence of reinforcement or foundations in old buildings. The condition of foundations in existing structures is often determined by relying on excavation and foundation exploration processes to accurately assess their condition



**Figure 3.13.** Foundation strengthening [32].

### 3.4 Concluding remarks on the strengthening techniques

To choose a suitable method for reinforcing buildings, several factors must be considered, such as the available budget, new loading requirements, environmental conditions, and the extent of the impact of the work on the building's future use. Table 3.1 presents a comparison of techniques for strengthening reinforced concrete buildings in terms of strength, flexibility, and durability.

**Table 3.1.** comparison of the most important repair and strengthening techniques for RC building [12].

	Strength	Stiffness	Ductility	Seismic Demand
RC jackets	X	X	X	
New shear walls	X	X	X	
Steel bracing	X	X	X	
FRP Wrapping	X		X	
FRP Laminates	X			
Steel Plates	X		X	
Seismic isolation				X

Based on the provided summary and upcoming analysis, it appears that techniques for reinforcing reinforced concrete buildings focus on enhancing strength, stiffness, and flexibility, while also addressing seismic demands. Each method has its advantages and disadvantages, which will be further evaluated through comparative analysis

### 3.5 Conclusion

In conclusion, we can infer that repairing reinforced concrete buildings is vital for maintaining the infrastructure of society and the safety of its citizens. By focusing on implementing proper techniques and utilizing advanced technologies, we can enhance the durability and structural integrity of these buildings, thus improving safety and security for everyone.

# **Chapter 04**

## **Case Study**

## 4.1. Introduction

In this chapter, we will apply what we have explained in previous chapters, where we will examine the structure of RC building that does not comply with modern seismic design methods.

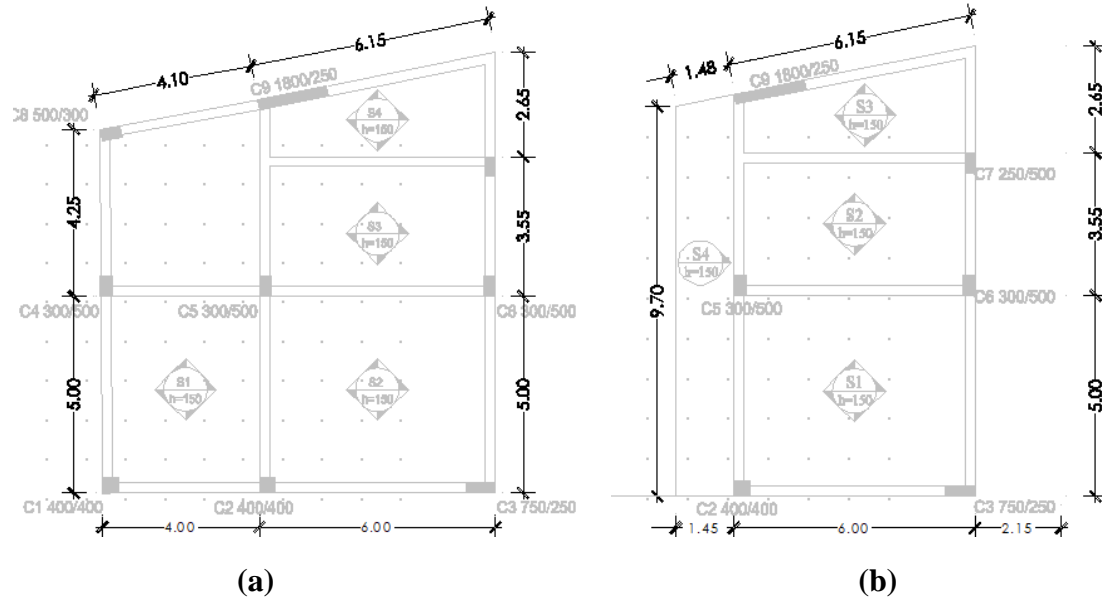
The examination of an existing RC building involves determining the complete configuration of the building, such as component dimensions and longitudinal and transverse reinforcement of the structure. This includes conducting inspections and tests on the concrete material using the necessary tools. After gathering all the information about the existing RC building, it is entered into the engineering software SeismoBuild in order to perform the necessary assessments and identify weak elements.

Once the weak elements of the structure are identified, we can use some techniques as solutions to strengthen these weak elements and compare between them.

## 4.2. Description of the existed building

A two-story reinforced concrete building was selected from literature [33]. The building has irregular construction with two bays in both X and Y directions, each floor being 3.0 meters high. It employs a Dual System for lateral load resistance, consisting of frames with shear walls. Originally the building was not designed for seismic considerations, the structure is subjected to uniform gravity loads, with 5 kN/m<sup>2</sup> dead load and 2 kN/m<sup>2</sup> live load on the floor. Seismic masses at floor level are calculated by adding 20% of the live load to the dead load. The building is residential and situated on medium soil (Type C per Eurocode 8) in a high seismicity area with a PGA = 0.35 g. Material and section details are provided in Table 4.1, respectively. The level of knowledge, indicated by the K factor (1.35 as per Eurocode 8 part 1.3 [20]), is relatively low, reflecting limited understanding or documentation about the structural aspects.

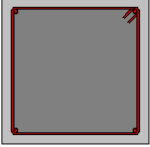




It's crucial to recognize that the chosen structure has been adapted to suit the particular emphasis of our study. These adjustments were implemented to better align the framework with the criteria and goals delineated in our research.



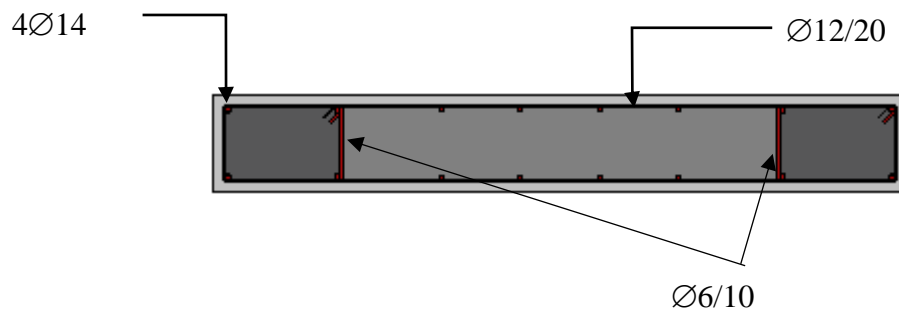
**Figure 4.1** Plan view of the studied building, a) 1st Floor, b) 2nd Floor.

- The dimensions and reinforcement of the columns are displayed in the following table.

**Table 4.1** The dimensions and reinforcement of the columns.

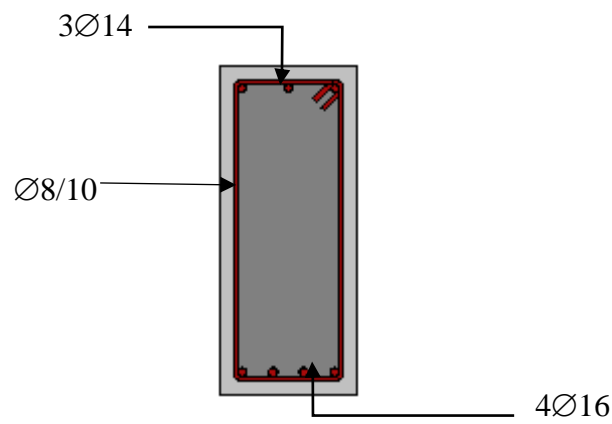
Columns	Height (mm)	Width (mm)	Longitudinal reinforcement	Transverse reinforcement	
C1	400	400	4 $\varnothing$ 12	$\varnothing$ 6/20	
C2	400	400	4 $\varnothing$ 12	$\varnothing$ 6/20	
C3	700	250	4 $\varnothing$ 12	$\varnothing$ 6/20	
C4	300	500	4 $\varnothing$ 12	$\varnothing$ 6/20	
C5	300	500	4 $\varnothing$ 12	$\varnothing$ 6/20	
C6	300	500	4 $\varnothing$ 12	$\varnothing$ 6/20	
C7	250	500	4 $\varnothing$ 12	$\varnothing$ 6/20	
C8	500	300	4 $\varnothing$ 12	$\varnothing$ 6/20	

The dimensions and reinforcement of the shear wall are displayed in Figure 4.2.

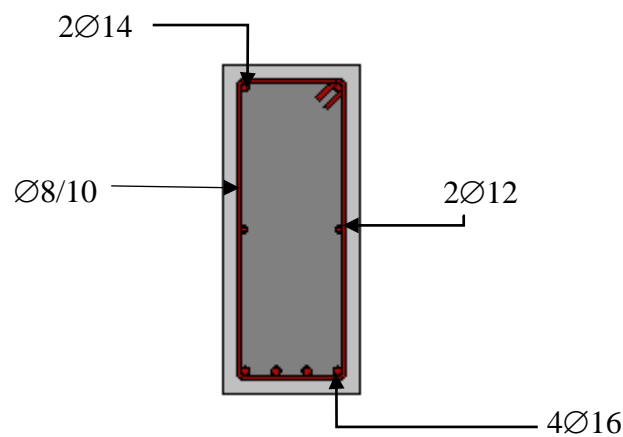


**Figure 4.2** The dimensions and reinforcement of the shear wall.

The dimensions and reinforcement of the Beams (600/250mm) are displayed in the following figures (Figure 4.3 to 4.5).

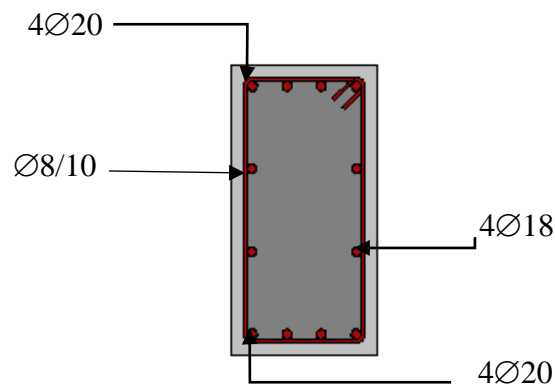


**Figure 4.3** Reinforcement at the Start of the beam.



**Figure 4.4** Reinforcement at the Middle of the beam.

Reinforcement at the End of the beam:

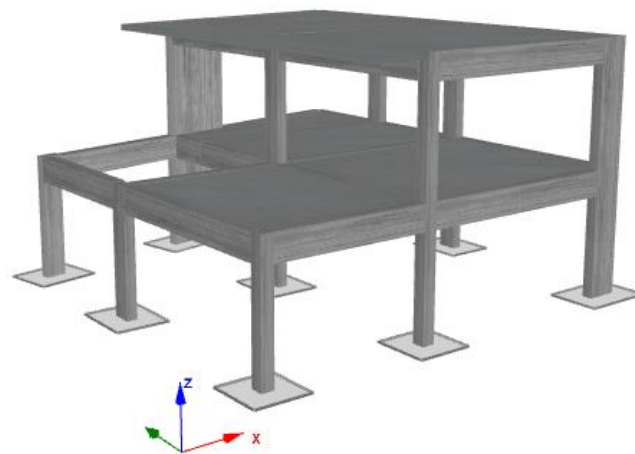


**Figure 4.5** Reinforcement at the End of the beam.

### 4.3. Building modeling

To conduct the inspection and evaluation of the reinforced concrete structure, we can examine the building identifying its complete configuration, and determine all the characteristics of the structure, concrete, and reinforcement using tools and equipment such as Ultrasound pulse velocity test and Rebound hammer. Then, the structure is modeled using the software SeismoBuild [29], which is one of the engineering programs specialized in assessing RC buildings against seismic loads.

All columns and beams are included with their dimensions and reinforcement, using a CAD drawing import for the background to facilitate defining the structural elements' geometry, as shown in **Figure 4.6**.



**Figure 4.6** 3D view of the studied building.

## 4.4. Code requirements

The Information is defined as follows:

**Limit stat:** Utilize the available limit state combinations in Eurocode 8 [30] for assessments (damage limitation, and Significant Damage).

**Limit stat of Damage Limitation (DL):** The structure has sustained only minor damage, with its structural elements maintaining their strength and stiffness. While non-structural components may exhibit distributed cracking, the damage is economically repairable, and permanent drifts are negligible.

**Limit stat of Significant Damage (SD):** The structure is significantly damaged, retaining some residual lateral strength and stiffness. Many non-structural components are damaged, and moderate permanent drifts are present.

**Seismic action:** we used a response spectrum type 1, and situated on medium soil (type C per Eurocode 8), high seismicity region with 0.35 PGA, 5% damping.

**Analysis type:** nonlinear static analysis with basic load patterns is used.

**Knowledge level:** Select a knowledge level 1 and confidence factor of 1.35.

**Checks:** Define all the verifications to conduct on the structure.

## 4.5. Results and discussion

### 4.5.1. Preliminary results

**Table 4.2** presents the modal characteristics of the studied frames in terms of the period and the modal mass participation ratio for the first three modes of vibration.

**Table 4.2.** Modal characteristics of the studied building

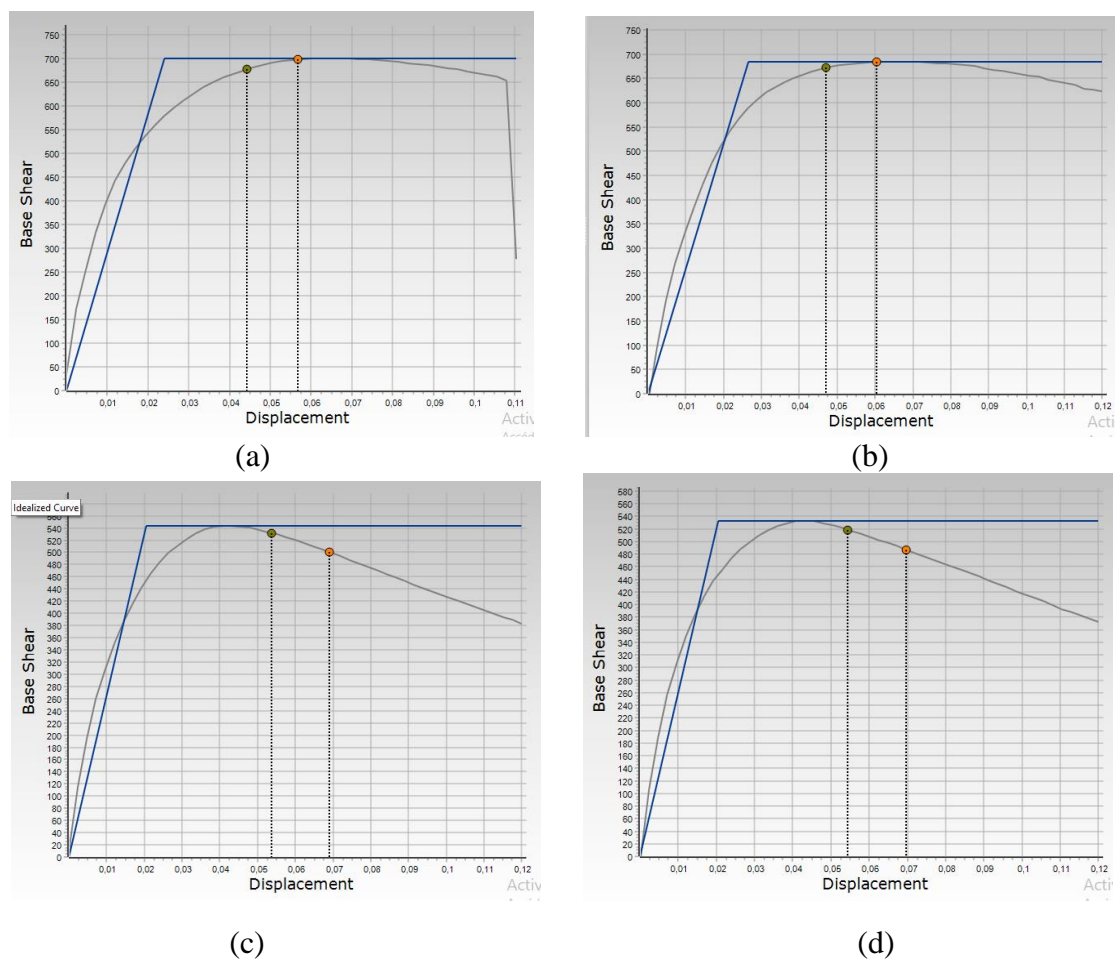
Modes number	Period (Sec)	Effective modal mass percentages (%)
1	0.44	87,73 (Y)
2	0.39	57,23 (X)
3	0.19	38,82 (RZ)

The first mode, with a period of 0.44 seconds, indicates a significant amount of the building's mass (87.73%) is participating in the Y direction as depicted in table 4.2. This longer period suggests that the building is relatively weak and flexible in this direction. In comparison, the second mode, which

has a period of 0.39 seconds, involves 57.23 % of the building's mass and primarily represents translation in the X direction. The effective modal mass percentage here confirms that the building is weaker in the Y direction than in the X direction. The third mode, with a period of 0.19 seconds and involving 38.82 % of the building's mass, corresponds to torsional movement about the Z vertical axis.

#### 4.5.2. Pushover curves

The curves shown in **Figure 4.7** are pushover curves, illustrating the relationship between base shear and displacement in the x-direction. These curves analyze the response of the studied frames under various seismic load directions (+X, -X, +Y, -Y).



**Figure 4.7.** Pushover curves : a) modal +X b) modal -X, c) modal +Y, d) modal -Y.

All the curves in Figure 4.7 show a rapid increase in base shear with displacement until they reach a peak point. Afterward, it stabilizes, indicating that the system has become nonlinear and entered a softening phase after that. The stabilized point suggests that the building has reached its maximum response and has absorbed most of the seismic loads.

The provided curves in Figure 4.7a and 4.7b represent pushover curves of a building in X direction, considering the sign of the load. The first curve, for the X direction with positive direction, shows a rapid increase in base shear up to around 700 kN at a displacement of approximately 0.06 m. The second curve, for the X direction with negative sign, exhibits a similar rapid increase in base shear up to around 670 kN at a slightly higher displacement of about 0.065 m before softening.

The two pushover curves in Figure 4.7c and 4.7d confirm that the structure with positive load has a slightly higher peak base shear and allows more displacement before a significant drop in base shear compared to the structure with negative load sign.

### 4.5.3. Target displacement

After calculating the performance point for the four cases of loading, the target displacement values are shown in Table 4.3. These values are determined for each level of seismic loadings (DL and SD). For the all studied loading direction, the maximum values are given in the Y direction.

**Table 4.3.** Target displacement

Limit States	Loading Direction			
	modal +X	modal -X	modal +Y	modal -Y
<b>DL</b>	0,044	0,047	0,053	0,054
<b>SD</b>	0,056	0,060	0,068	0,069

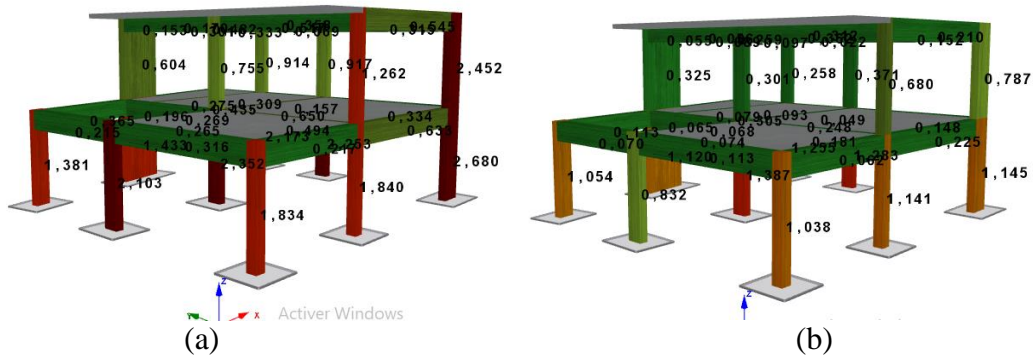
### 4.5.4. Elements check

Elements checks is the most important step to evaluate and assess the building behavior before and after retrofiting. Elements check results of the building are represented in Figure 4.8 for Members chord rotations and Figure 4.9 for Members shear forces:

#### a) Members chord rotations

The two images in Figure 4.8 show the structural performance check, in terms of member chord rotation, of the building elements for the two limit states: Damage limitation (Figure 4.8a) and significant damage (Figure 4.8b). The performance ratios are indicated for each element, with numbers greater than 1 signifying that the element fails the check and requires strengthening, while numbers less than 1 denote safety. In the Damage limitation state, several elements exceed the safe threshold, particularly the columns with values like 2.452 and 2.680, indicating significant vulnerability. In the

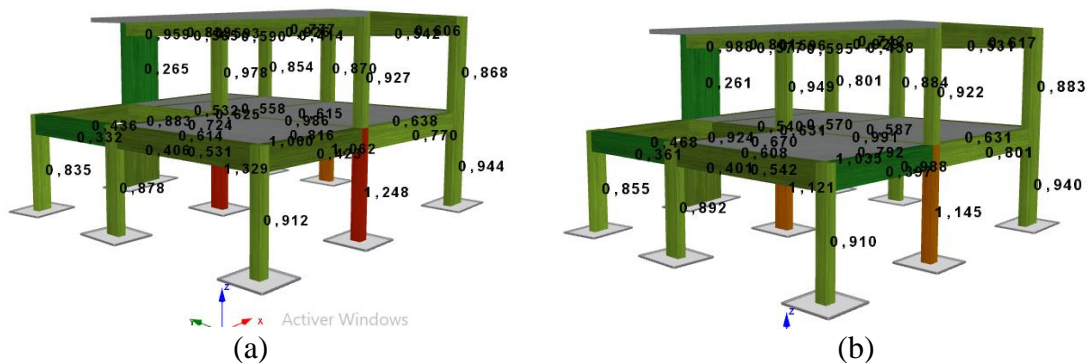
Significant damage state, more elements display critical ratios above 1, such as 2.154 and 1.787, highlighting the necessity for strengthen to ensure structural integrity under severe conditions.



**Figure 4.8.** Members chord rotations of the studied building, a) For Damage limitation DL b) Significant damage SD.

### b) Members shear forces:

Figure 4.9 presents the results of shear force check for two limits states also.

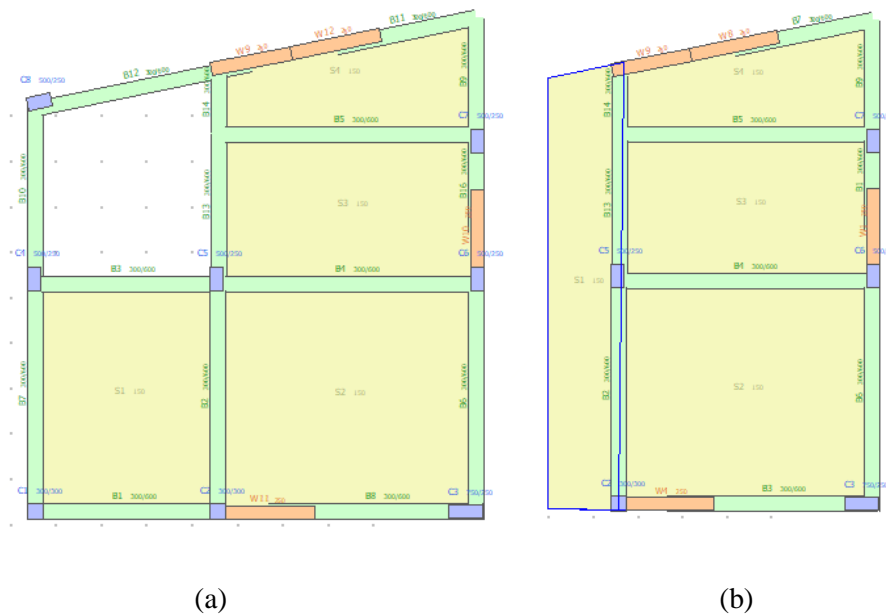


**Figure 4.9.** b) Members shear forces of the studied building, a) For Damage limitation DL b) Significant damage SD.

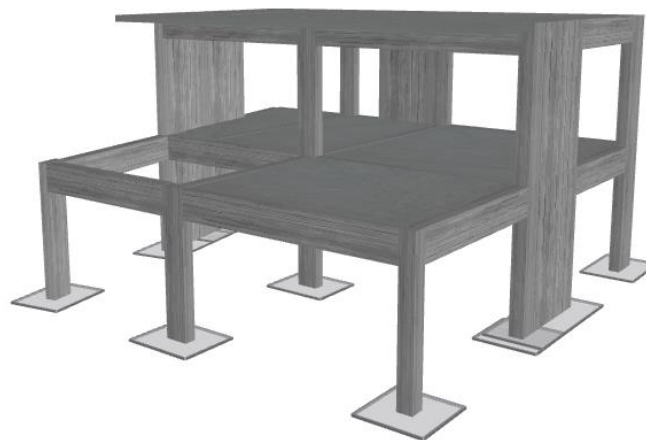
The two images in Figure 4.9 represent the shear force performance check of a building for two limit states: Damage limitation (left) and Significant damage (right). The performance ratios are displayed for each structural element. In the Damage limitation state, most elements are within safe limits, although one column shows a critical value of 1.248, necessitating strengthen. In the significant damage state, the majority of elements also appear safe, with the highest ratio being 1.145, indicating potential issues but less severe compared to the limit damage state. Overall, these figures suggest that while the building performs adequately under shear forces, some elements require attention to ensure full structural safety under extreme conditions.

#### 4.6. Building strengthen by adding shear walls

To enhance the building's structural integrity without adversely affecting its seismic behavior, new shear walls should be strategically added in locations where they will not induce torsion effects. These placements should be carefully selected to improve overall stability and distribute shear forces more effectively while maintaining the building's symmetrical response to seismic loads. This approach ensures both safety and performance without compromising the building's dynamic characteristics. Figures 4.10 and 4.11 show the new added shear walls.



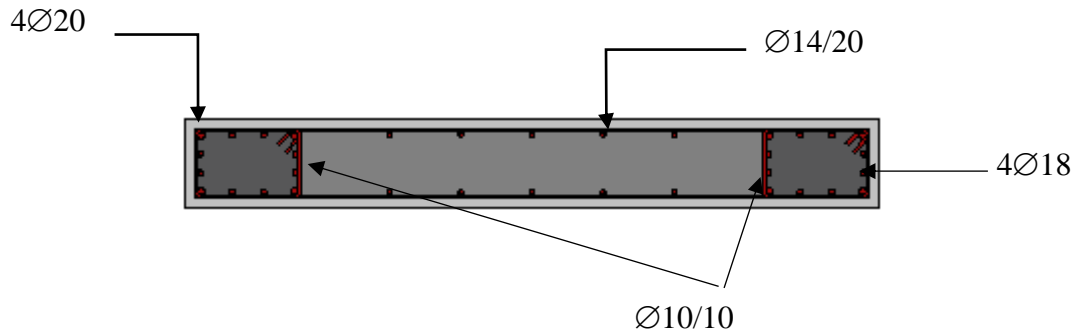
**Figure 4.9.** Plan view of the Building strengthen by adding shear walls, a) First Floor, b) second Floor.



**Figure 4.10** 3D view of the Building strengthen by adding shear walls.

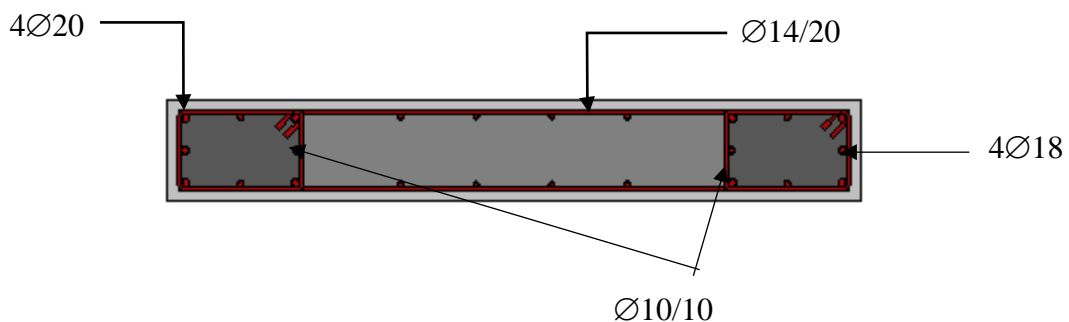
#### 4.6.1. Reinforcements of the new shear walls

- The dimensions and reinforcement of the new shear walls W11 and W12 (2000/250) mm are displayed in the following figure.



**Figure 4.11** The dimensions and reinforcement of the new shear wall (W11, and W12).

- The dimensions and reinforcement of the new shear wall W10 (1700/250) mm are displayed in the following figure.



**Figure 4.12** The dimensions and reinforcement of the new shear wall w10.

#### 4.6.2. Periods and modal mass participation

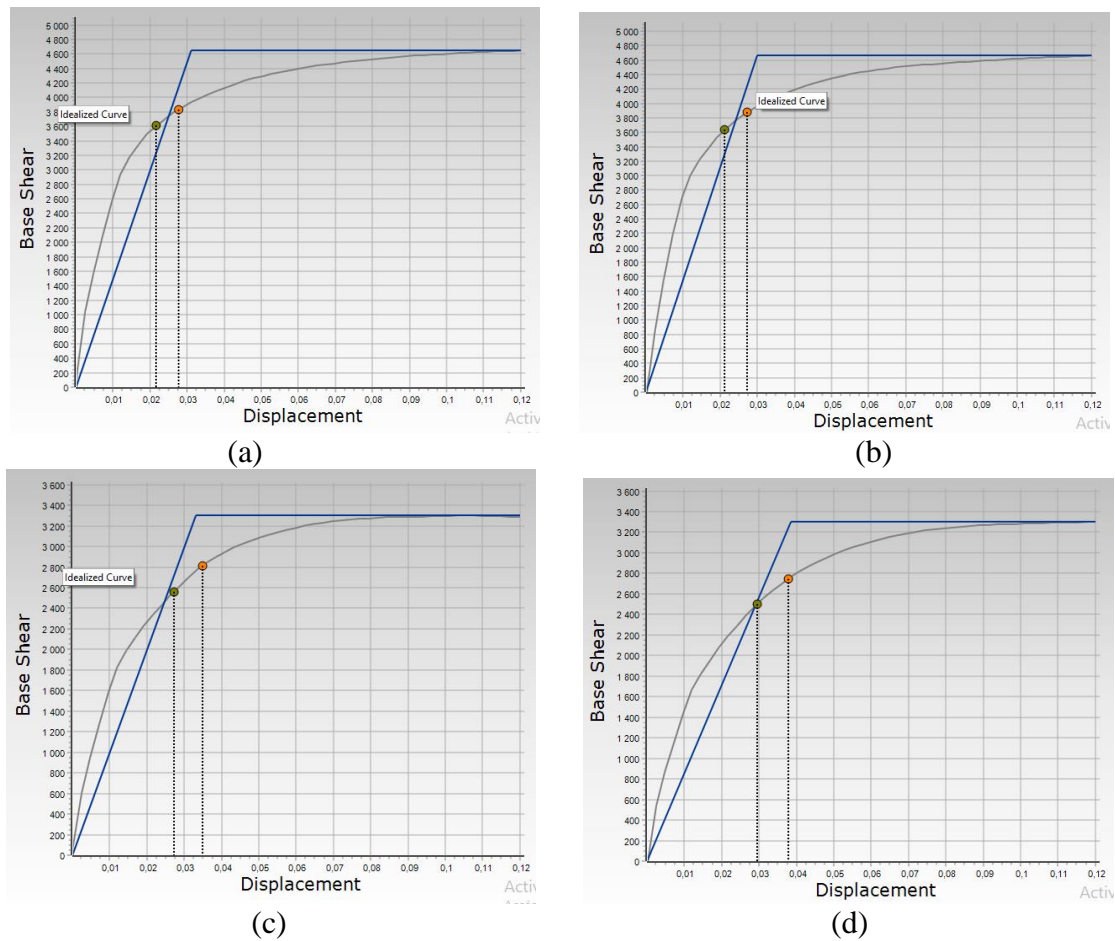
The Table 4.4 shows the modal characteristics of a building reinforced with shear walls, highlighting three significant modes. Mode 1, with a period of 0.19 seconds, accounts for 79.75% of the effective modal mass in the Y-direction. Mode 2, with a period of 0.13 seconds, captures 75.69% of the mass in the X-direction. Mode 3, with a period of 0.08 seconds, encompasses 85.47% of the mass in the rotational Z-direction (RZ). These results indicate that the addition of shear walls effectively increases the building's stiffness, enhancing its seismic performance by ensuring substantial mass participation across both translational and rotational modes.

**Table 4.4.** Modal characteristics of the Building strengthen by adding shear walls

Modes number	Period (Sec)	Effective modal mass percentages (%)
1	0.19	79,75 (Y)
2	0.13	75,69 (X)
3	0.08	85,47 (RZ)

### 4.6.3. Pushover curves

The four Figures 4.13a to 4.13d display pushover curves for a building strengthened with shear walls in X and Y directions, showing responses under modal load distributions in positive and negative signs. In each figure, base shear versus displacement is plotted, highlighting the building's capacity and ductility under lateral loads. The curves indicate a higher initial stiffness and strength in the X direction (Figures a and b) compared to the Y direction (Figures c and d). The idealized curves demonstrate that the building can sustain substantial base shear before significant displacements occur. Variations between positive and negative loading directions suggest some asymmetry in the building's performance, underscoring areas where additional strengthening might be necessary to ensure uniform resilience against seismic forces.



**Figure 4.13.** Pushover curves of the Building strengthened by adding shear walls in x Direction, a) modal +X b) modal -X, c) modal +Y, d) modal -Y.

#### 4.6.4. Target displacement

The table 4.5 presents the target displacements, also known as performance points, for each loading case in different directions and limit states. The limit states are defined as DL (Damage Limitation) and SD (Significant Damage). For the X and -X directions, the target displacement values are identical, with 0.021 m for DL and 0.027 m for SD, indicating symmetrical performance in these directions. In the Y direction, the target displacement increases slightly to 0.027 m for DL and 0.034 m for SD, while in the -Y direction, the values further increase to 0.029 m for DL and 0.037 m for SD. These differences suggest that the building experiences greater displacements and potentially more vulnerability in the Y and -Y directions.

**Table 4.5.** Target displacements.

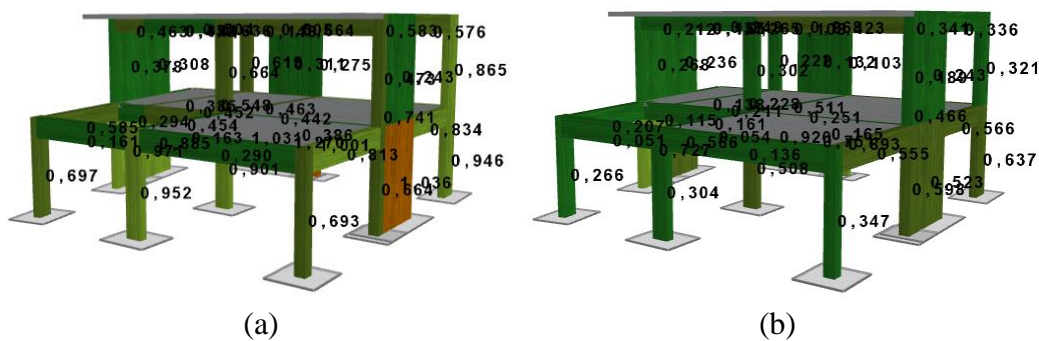
Limit States	Loading Direction			
	X	-X	Y	-Y
<b>DL</b>	0,021	0,021	0,027	0,029
<b>SD</b>	0,027	0,027	0,034	0,037

#### 4.6.5. Capacity check

Capacity check for the building elements after adding new shear walls is presented as follow:

##### a) Members chord rotations:

The images illustrate the members' chord rotations of a building strengthened by adding shear walls for two limit states: Damage Limitation (DL) and Significant Damage (SD). In figure 4.14a, representing the DL state, most chord rotations are below the threshold, indicating that the elements remain within acceptable rotation limits under minor seismic events. A few elements, particularly in the lower floors, show higher rotation values but remain generally safe. In figure 4.14b, representing the SD state, the chord rotations are higher, especially in the same critical areas, indicating more significant deformations under severe seismic conditions. The data suggest that while the shear walls effectively enhance overall stability, some members still exhibit high rotations, necessitating further strengthening to ensure they perform well under both minor and major seismic loads.

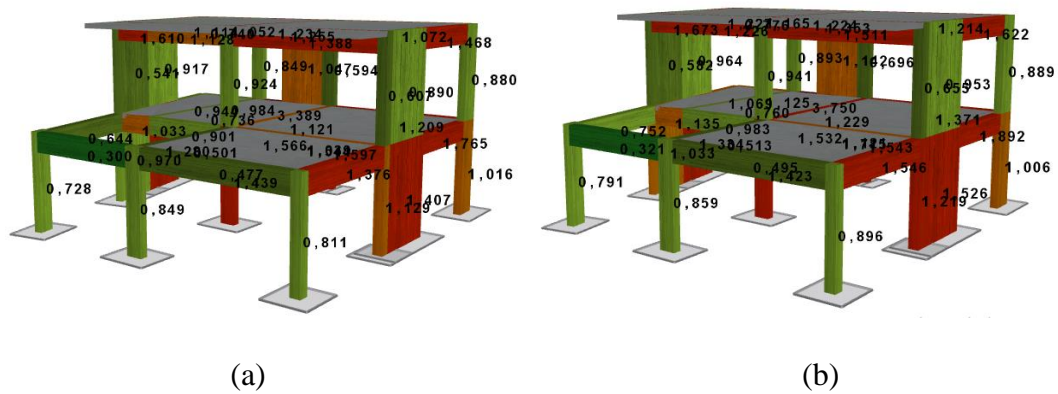


**Figure 4.14.** Members chord rotations of the Building strengthened by adding shear walls, a) For Damage limitation DL b) Significant damage SD.

##### b) Members shear forces:

The images in Figure 4.15 show the shear force analysis for a building with added shear walls under two limit states: DL and SD. In the DL state (figure 4.15a), most members have shear forces below the critical threshold, indicating sufficient resistance under minor seismic loads, though a few

elements in the lower floors exceed 1.0, needing reinforcement. In the SD state (figure 4.15b), shear forces are higher overall, with several members surpassing 1.0, indicating increased stress under severe conditions. These results suggest that while shear walls improve resistance, critical members still require additional strengthening.

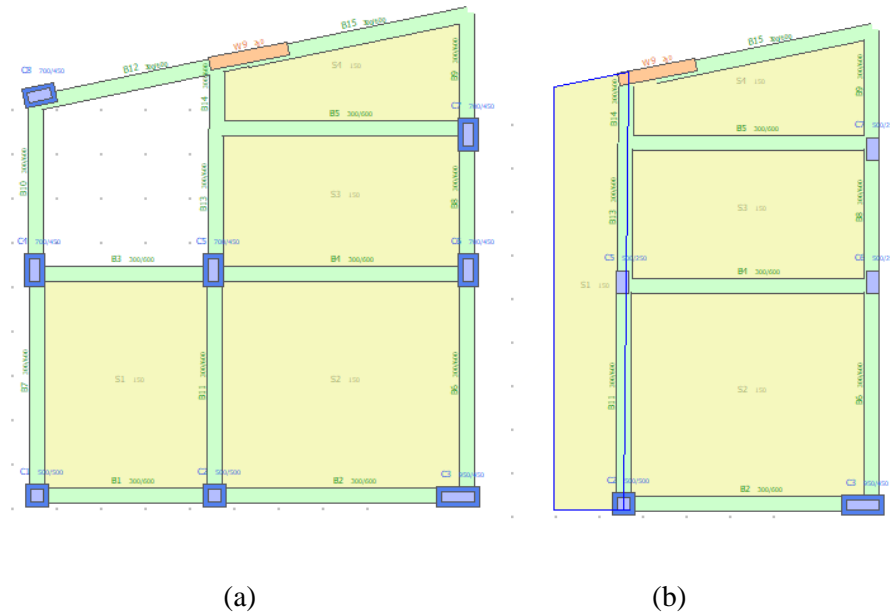


**Figure 4.15.** Members shear forces of the Building strengthened by adding shear walls, a) For Damage limitation DL b) Significant damage SD.

#### 4.7. Building strengthen by elements jacketing

Given that the added shear walls did not sufficiently improve performance and some elements still failed the checks, the next step will be to strengthen the building by jacketing the critical elements. This approach will enhance their capacity to withstand seismic forces more effectively, ensuring that all structural components meet safety requirements. This method addresses the deficiencies observed in the shear wall strategy.

The specific elements to be strengthened by jacketing are mentioned in the following figures.



**Figure 4.16.** Plan view of the Building strengthened by elements jacking, a) First Floor, b) second Floor.

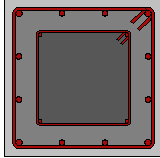
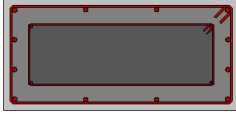
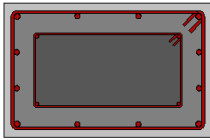
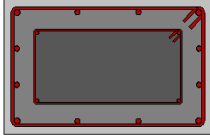
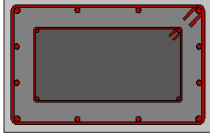


**Figure 4.17** 3D view of the Building strengthened by elements jacking.

#### 4.7.1 Reinforcements of the elements jacking

The dimensions and reinforcement of the columns jacking are displayed in the following table.

**Table 4.6** The dimensions and reinforcement of the columns jacketing .

Columns	Height (mm)	Width (mm)	Longitudinal reinforcement	Transverse reinforcement	
C1	600	600	4Ø20+8Ø18	Ø10/10	
C2	600	600	4Ø20+4Ø18	Ø10/10	
C3	950	450	4Ø20+4Ø18	Ø10/10	
C4	500	700	4Ø20+4Ø18	Ø6/20	
C5	500	700	4Ø20+4Ø18	Ø6/20	
C6	500	700	4Ø20+4Ø18	Ø6/20	
C7	450	700	4Ø20+4Ø18	Ø6/20	
C8	700	500	4Ø20+4Ø18	Ø6/20	

#### 4.7.2 Periods and modal mass participation

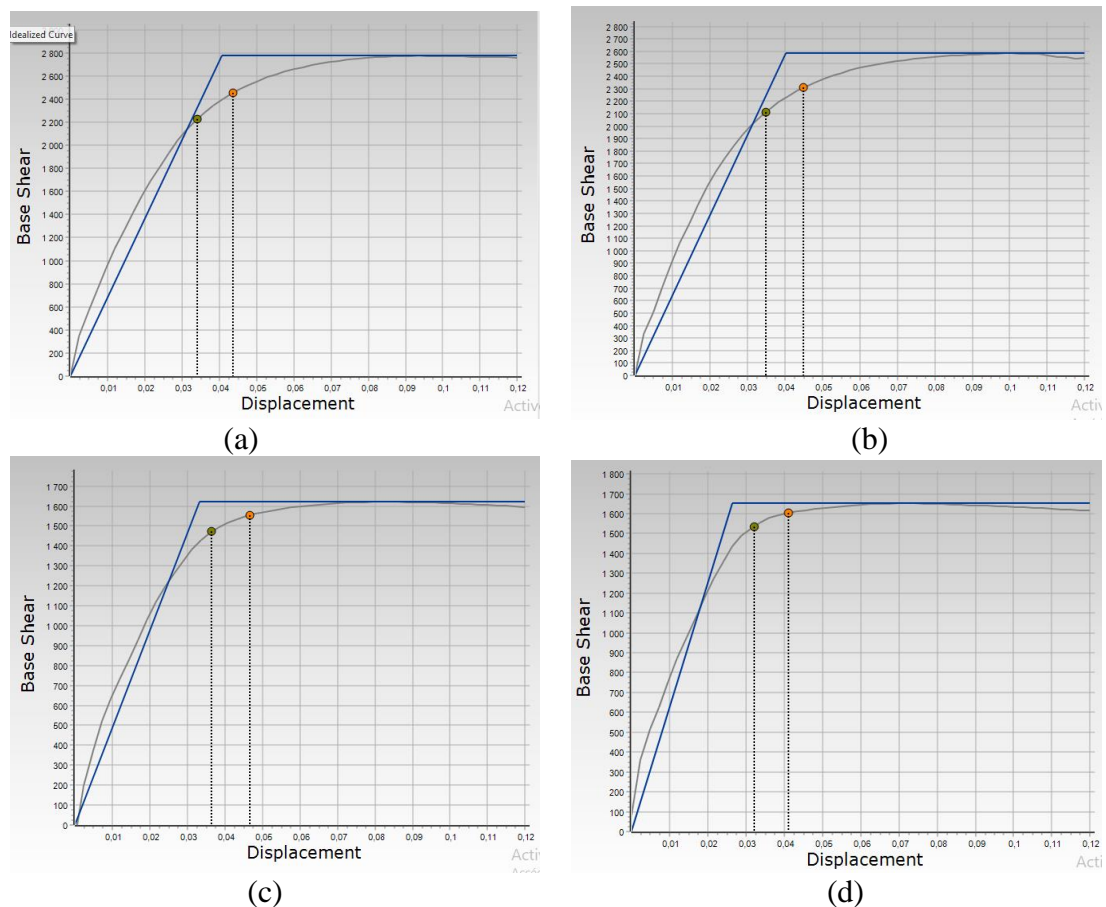
The table 4.7 presents the modal characteristics of a building strengthened by jacketing critical elements. The first mode has a period of 0.27 seconds, capturing 68.53% of the effective modal mass in the Y-direction. The second mode has a period of 0.23 seconds, with 72.34% of the modal mass in the X-direction. The third mode has a period of 0.16 seconds, covering 78.87% of the modal mass in the rotational Z-direction (RZ). These results suggest that jacketing has altered the building's dynamic properties, resulting in increased periods and effective mass participation percentages, thus improving the structure's overall seismic performance.

**Table 4.7.** Modal characteristics of the Building strengthened by elements jacketing

Modes number	Period (Sec)	Effective modal mass percentages (%)
1	0.27	68,53 (Y)
2	0.23	72,34 (X)
3	0.16	78,87 (RZ)

### 4.7.3 Pushover curves

The pushover curves for the building strengthened by jacketing (shown in figures 4.18a, b, c, and d) display the base shear versus displacement for loading in the X and Y directions and their opposite signs. These curves indicate improved performance compared to the previous shear wall strategy, with higher base shear capacities and more consistent displacement responses. Notably, the jacketing approach results in higher stiffness and ductility, evident from the steeper initial slopes and increased base shear values. Compared to the earlier curves, the jacketing effectively enhances the building's resilience under seismic loads, demonstrating a more uniform and robust structural response across different loading scenarios.



**Figure 4.18.** Pushover curves of the Building strengthened by elements jacketing in Direction, a) modal +X b) modal -X, c) modal +Y,d) modal -Y

#### 4.7.4 Target displacement

The table 4.8 shows target displacements for the building strengthened by jacketing under different loading directions and limit states (Damage Limitation, DL, and Significant Damage, SD). For DL, the target displacements range from 0.032 m (-Y) to 0.036 m (+Y), slightly higher than the previous values for shear walls strategy, indicating an improved ability to absorb minor seismic impacts. For SD, the displacements range from 0.041 m (-Y) to 0.046 m (+Y), also higher than before, suggesting better performance under severe conditions. Compared to the earlier results where shear walls were added, the increased target displacements indicate that jacketing has enhanced the building's capacity to endure greater deformations while maintaining structural integrity, showing a more resilient seismic response across all directions.

**Table 4.8.** Target displacements.

Limit States	Loading Direction			
	+X	-X	+Y	-Y
<b>DL</b>	0,034	0,035	0,036	0,032
<b>SD</b>	0,043	0,044	0,046	0,041

#### 4.7.5 Capacity check

Capacity check for the building elements after jacketing some building elements is presented as follow:

##### a) Members chord rotations:

The images in figure 4.19 display member chord rotations for the building strengthened by jacketing under Damage Limitation (DL) and Significant Damage (SD) limit states. In figure 4.19a for DL, most members show low chord rotation values, indicating effective control of minor seismic deformations. However, a few critical elements, particularly in the upper floor, display higher rotations but still within manageable limits. In figure 4.19b for SD state, the chord rotations are generally higher but remain within acceptable ranges, reflecting improved performance under severe seismic conditions. Compared to the previous results with added shear walls, the jacketing approach significantly reduces chord rotations, demonstrating better overall stiffness and deformation control. This indicates that jacketing is a more effective strengthening method for enhancing the building's seismic resilience.



**Figure 4.19.** Member's chord rotations of the Building strengthened by elements jacking, a) For Damage limitation DL b) Significant damage SD.

### b) Members shear forces:

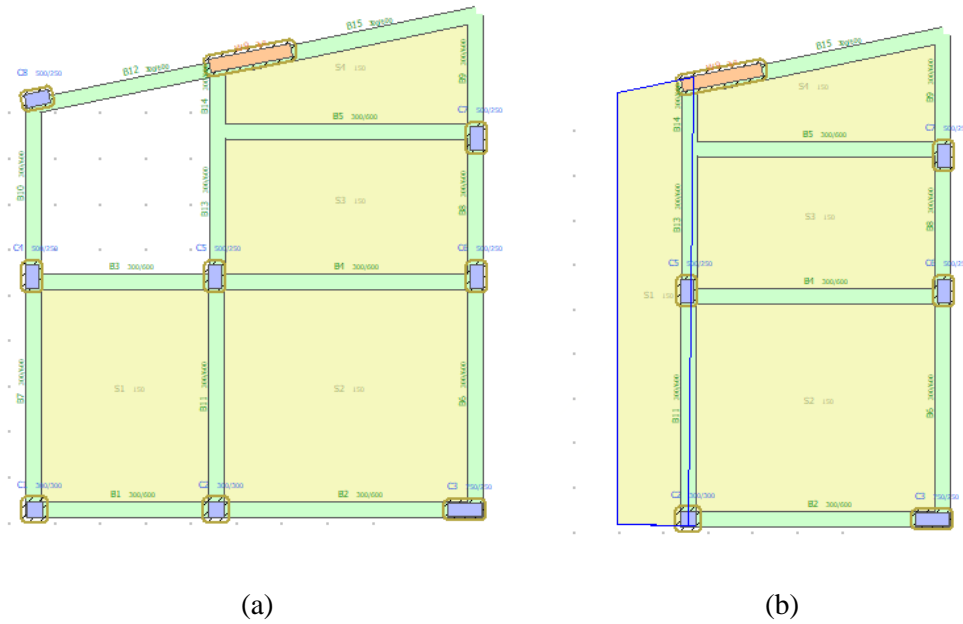
Figure 4.20 shows the shear forces in the building's members after strengthening by jacking. In figure 4.20a for DL state, most members show shear forces below the critical threshold, indicating effective shear resistance under minor seismic loads, although a few elements still approach the limit. In figure 4.20b for SD, shear forces are generally higher, with some members showing values close to or slightly exceeding the threshold, reflecting increased stress under severe conditions. Compared to the previous shear wall strategy, the jacking approach results in more uniform and improved shear force distribution, demonstrating better overall structural performance. Jacketing effectively reduces critical shear forces in key members, highlighting its superiority in enhancing seismic resilience compared to the addition of shear walls.



**Figure 4.20.** Members shear forces of the Building strengthened by elements jacking, a) For Damage limitation DL b) Significant damage SD.

#### 4.8. Building strengthen by FRP wrapping

In the final case, we will strengthen the building by applying FRP (Fiber Reinforced Polymer) wrapping to the critical elements. This method is expected to enhance the structural capacity and improve the seismic performance by providing additional strength and stiffness to the wrapped members. Figure 4.29 and 4.30 shows the strengthen element.



**Figure 4.21** Plan view of the Building strengthen by FRP wrapping, a) First Floor, b) second Floor.



**Figure 4.22.**D view of the Building strengthen by FRP wrapping.

### 4.8.1. FRP type

For the restoration process using FRP fibers, we use «SikaWrapA®-600C »fibers, which are considered a popular choice in restoration.

### 4.8.2. Periods and modal mass participation

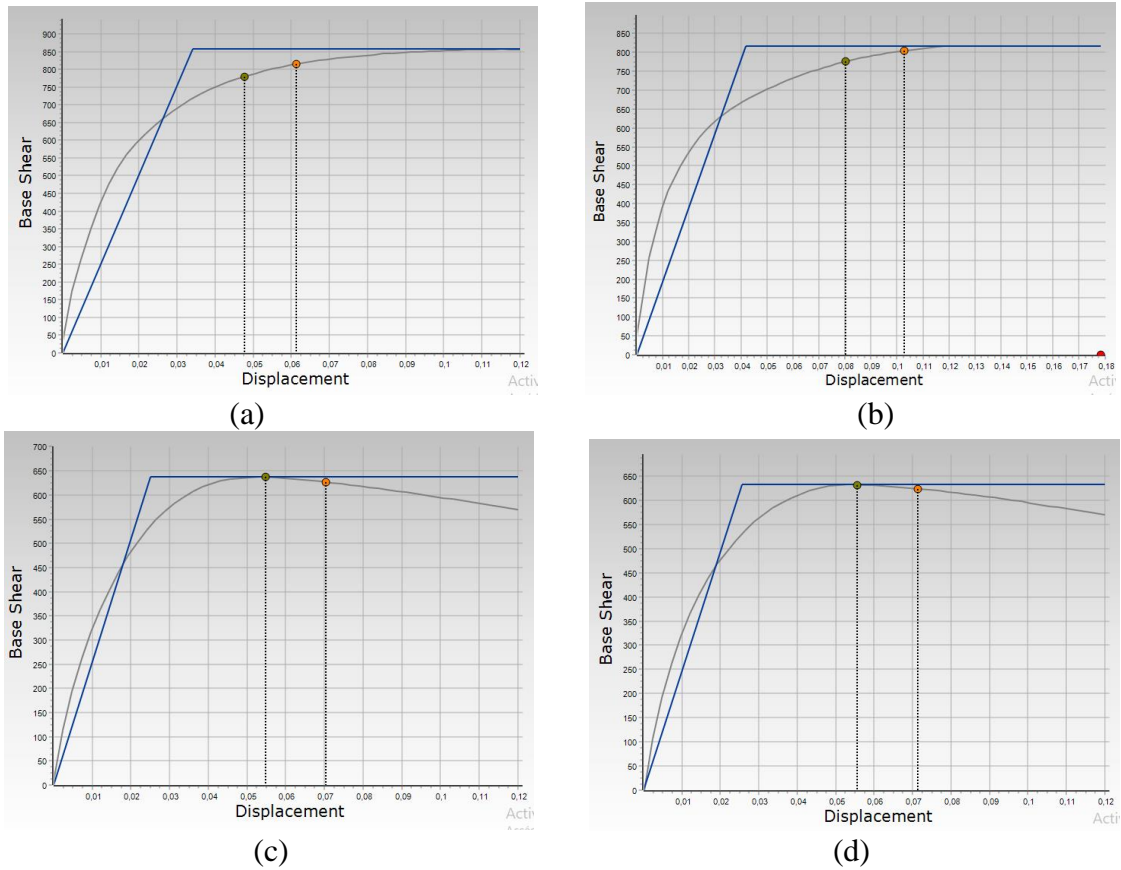
The table 4.12 presents the modal characteristics of the building strengthened by FRP (Fiber Reinforced Polymer) wrapping. The first mode has a period of 0.44 seconds, capturing 87.65% of the effective modal mass in the Y-direction. The second mode has a period of 0.39 seconds, with 57.31% of the modal mass in the X-direction. The third mode has a period of 0.19 seconds, covering 38.70% of the modal mass in the rotational Z-direction (RZ). Comparing these results with the initial structure before strengthening, there appears to be no significant change in the periods or modal mass percentages. This suggests that the FRP wrapping did not substantially alter the building's dynamic properties.

**Table 4.12.** Modal characteristics of the Building strengthen by FRP wrapping.

Modes number	Period (Sec)	Effective modal mass percentages (%)
1	0.44	87,65 (Y)
2	0.39	57,31 (X)
3	0.19	38,70 (RZ)

### 4.8.3. Pushover curves

The pushover curves for the building strengthened by FRP wrapping (figures a, b, c, and d) show improvements in base shear capacity and controlled displacements compared to the initial strengthened structure. However, the enhancements are less pronounced compared to the previous strengthening methods. The shear walls increased stiffness but had some elements that still failed checks. Jacketing provided the most significant improvement, offering higher base shear capacities and better seismic performance.



**Figure 4.23.** Shear curves of the Building strengthened by FRP wrapping in Direction, a) modal +X b) modal -X, c) modal +Y d) modal -Y.

#### 4.8.4. Target displacement

The table 4.13 shows target displacements for the building strengthened by FRP wrapping, with DL values ranging from 0.047 m (+X) to 0.055 m (-Y) and SD values from 0.061 m (+X) to 0.071 m (-Y). These displacements are higher than those achieved with previous strategies, indicating FRP wrapping allows for greater deformations before reaching limit states. Compared to shear walls, which provided moderate improvements with lower displacements, and jacketing, which offered balanced enhancements with slightly lower displacements but better stiffness and resilience, FRP wrapping demonstrates the highest displacement capacities.

**Table 4.13.** Target displacements.

Limit States	Loading Direction			
	+X	-X	+Y	-Y
<b>DL</b>	0,047	0,050	0,054	0,055
<b>SD</b>	0,061	0,064	0,070	0,071

### 4.8.5. Capacity check

Capacity check for the building elements after strengthening building element with FRP wrapping is presented as follow:

#### a) Members chord rotations:

Figure 4.27 illustrates member chord rotations for a building strengthened by FRP wrapping, evaluated for Damage Limitation (DL) and Significant Damage (SD) limit states. In the DL state (figure 4.27a), most members show acceptable rotations, though some elements, especially in the lower floors, exceed critical values. In the SD state (figure 4.27b), higher rotations suggest significant deformations under severe seismic conditions. Compared to other strategies, shear walls provide moderate improvements, but some elements still exhibit high rotations. Jacketing significantly reduces chord rotations, indicating better deformation control and enhanced stiffness. FRP wrapping improves displacement capacity but does not significantly alter chord rotations compared to the initial structure. Thus, while shear walls and FRP wrapping offer benefits, jacketing remains the most effective strategy for controlling chord rotations and improving seismic performance.



**Figure 4.24.**Members chord rotations of the Building strengthen by adding shear walls, a) For Damage limitation DL b) Significant damage SD.

#### b) Members shear forces:

Figure 4.28 shows member shear forces check when building elements strengthened by FRP wrapping under Damage Limitation (DL) and Significant Damage (SD) limit states. In the DL state (figure a), most members exhibit shear forces below critical thresholds, indicating good resistance to minor seismic loads. In the SD state (figure b), shear forces increase but remain within acceptable limits, demonstrating adequate performance under severe conditions. Compared to other strategies,

FRP wrapping provides moderate shear force resistance similar to shear walls but with slightly better performance. However, jacketing remains the most effective method, significantly reducing shear forces and improving overall structural performance. While FRP wrapping enhances flexibility and displacement capacity, it is less effective in reducing shear forces compared to jacketing, making it a less balanced yet beneficial approach.



**Figure 4.25.** Members shear forces of the Building strengthened by FRP wrapping, a) For Damage limitation DL b) Significant damage SD.

## 4.9. Conclusion

The study evaluated different strengthening strategies for a building under seismic loads, including shear walls, jacketing, and FRP wrapping. Shear walls provided moderate improvements in stiffness and shear force resistance but did not sufficiently enhance overall performance. Jacketing proved to be the most effective method, significantly reducing chord rotations and shear forces, and improving seismic resilience. FRP wrapping increased displacement capacity and provided moderate shear resistance, offering flexibility but less stiffness improvement compared to jacketing. Overall, while each method offered benefits, jacketing emerged as the best strategy for enhancing structural integrity and seismic performance, making it the recommended approach for comprehensive building reinforcement.

# **General conclusion**

## General conclusion

In seismic-prone areas, the structural integrity and safety of buildings are paramount. The primary objective of this study was to explore and evaluate various structural strengthening methods to enhance the seismic performance of buildings. By examining the effectiveness of shear walls, jacketing, and FRP wrapping, this research aimed to identify the most efficient strategy for improving building resilience against seismic forces. The need for such strengthening is critical to minimize damage, ensure safety, and extend the lifespan of structures subjected to frequent seismic activities.

The study began with a literature review on seismic behavior of RC buildings, strengthening techniques and their impact on building performance. Using a detailed case study approach, the building's performance was analyzed under various strengthening scenarios. The pushover analysis, target displacements, chord rotations, and shear force checks provided a comprehensive understanding of how each method influenced the building's seismic response. Shear walls offered some improvement in stiffness and shear resistance but fell short in uniformly enhancing overall performance. FRP wrapping showed increased displacement capacity and moderate shear resistance, making it a flexible yet less stiff solution.

Jacketing emerged as the most effective strategy, demonstrating significant improvements across all performance metrics. It effectively reduced chord rotations and shear forces, indicating better control over deformations and enhanced stiffness. The comparative analysis clearly showed that jacketing provided a balanced enhancement of the building's seismic resilience, outperforming both shear walls and FRP wrapping in critical aspects of structural integrity.

In conclusion, this study underscores the importance of selecting appropriate strengthening methods to safeguard buildings in seismic regions. While each method has its benefits, jacketing proved to be the most comprehensive solution, offering substantial improvements in both stiffness and flexibility. These findings contribute valuable insights into structural engineering practices and can guide future efforts to reinforce buildings against seismic hazards, ultimately ensuring greater safety and durability in earthquake-prone areas.

## Bibliographic reference

- [1]: TaMara M ,Editor-in-Chief, Turner-Fairbank,(1996), " Federal highway Administration", Highway Research Center, United States, <https://highways.dot.gov/public-roads/fall-1996/aftermath-kobe-earthquake>
- [2]: a flagship public research university ,(1885), "Michigan Technological University", <https://www.mtu.edu/>.
- [3]: The website aims to provide diverse and comprehensive geographical information, (1996), "the world atlas", <https://www.worldatlas.com/>
- [4]:" The British Geological Survey (BGS)", (1835), by Henry De la Beche, making it the world's oldest national geological survey.
- [5]: a scientific agency of the U.S. government ,( March 3, 1879), " United States Geological Survey (USGS)", operates under the U.S. Department of the Interior.
- [6]: Algerian Seismic Rules ,(2003), "RPA 99/ Version 2003",Algerian.
- [7]: "SK Super TMT", the epitome of purity, perfection and precision , Copyright ©2020 SK STEELTECH PVT LTD. All Rights Reserved ,<https://www.skstpertmt.com/>
- [8]: ResearchGate GmbH , (2008-2024) ,"ResearchGate", <https://www.researchgate.net/> .
- [9]: "Structural Guide", (2024), Designed by Kits, <https://www.structuralguide.com/>.
- [10]: C.V.R.Murty, Goswami R, A.R.Viyanarayanan, Vipul V.Mehta" Earthquake behavior of buildings",Gujarat State Disaster Management Authority.
- [11]: Dr. Michael A, (2021), " Rebar Detection Methodology" ,from Screening Eagle Technologies.
- [12]: Stelios Antoniou, (2023)," Seismic retrofit of Existing Reinforced Concrete Buildins", 2023©John Wiley & Sons Ltd.
- [13]: "Discoveries Engineering: Unveiling Innovati ons in Engineering", <https://engineeringdiscoveries.com/>
- [14]: a specialty chemicals company, "Sika Group", <https://www.sika.com/>.
- [15]: Abd alrahman Assi, (2019), "Chaafmix", <https://www.shaaafmix.com/2022/04/181.html?m=1>
- [16]: The free encyclopedia, "WIKIPEDIA", <https://www.wikipedia.org/>.
- [17]: Mohamed adel Tohami,"introduction to pushover analysis and capacity spectrum method",You Tub 18/07/2018,<https://youtube.com/@mohamedadel-ln3mm?si=ZpDTyjiegboYiwLo>
- [18]:"MDPI", (1996-2024), MDPI (Basel,Switzerland), <https://www.mdpi.com/> [18]: "Bentely", <https://www.bentley.com/>
- [19]: American Society of Civil Engineers. (2016). ASCE 7-16: Minimum Design Loads and Associated Criteria for Buildings and Other Structures. Reston, VA: American Society of Civil Engineers.
- [20]: Eurocode 8: Design of structures for earthquake resistance – Part 3: General rules, seismic actions and rules for buildings (EN 1998-1:2004), p. 23. Brussels: CEN.
- [21]: "Gratitec", ( 1986), <https://gratitec.com/uk/>
- [22]: Seismic Evaluation and Retrofit of Existing Buildings. Reston, (2017), "ASCE 41-17", VA: American Society of Civil Engineers.

- [23]: "Seismosoft" , was released in the early 2000s, for evaluating and strengthening RC structures against seismic loads.
- [24]: The Italian National Seismic Code includes both, (2008), "The Italian National Seismic Code includes both NTC-18 and NTC-08".
- [25]: The Greek Seismic Intervention Code, (2000), "KANEPE", sets the standards and guidelines for seismic interventions and measures to enhance the seismic resilience of structures in Greece.
- [26]: The Turkish Seismic Evaluation Code, (2007), "TBDY", outlines the criteria and procedures for evaluating structures against seismic hazards in Turkey.
- [27]: "Engineering et Architecture", (2024), Le coffrage,  
<https://genieciviletravauxpublics.blogspot.com/2018/11/le-coffrage.html>
- [28]: "Seismic Retrofitting Techniques for Concrete Structures,Gopal Mishra", (2016),  
<https://theconstructor.org/concrete/seismic-retrofitting-techniques-concrete-structures/11767/?amp=1>.
- [29]: "Civil Wall", (2018 – 2024),<https://civilwale.com/>.
- [30]: Deluxe Bathrooms & Tiling Solutions UK, (2024), "DULUXE BATHROMES",  
<https://deluxebathrooms.co.uk/products/ardex-p10-sr-crack-repair-resin-kit>
- [31]: "IndiaMART", is a popular online marketplace connecting buyers with suppliers in India.<https://m.indiamart.com/>
- [32]: " Horse Construction: Structural Strengthening Materials", (2006), <https://www.horseen.com/>
- [33]: SeismoBuild V 2023, developed by Seismosoft, USA.