



الجمهورية الجزائرية الديمقراطية الشعبية
The People's Democratic Republic of Algeria
وزارة التعليم العالي والبحث العلمي
Ministry of Higher Education and Scientific Research
جامعة محمد بoudiaf المسيلة
University Mohamed Boudiaf of M'sila



كلية الرياضيات والعالم الآلي
Faculty of Mathematics and Informatics

قسم العالم الآلي
Department of Computer Science

Domain: Mathematics and Computer Science

Thesis Presented to Fulfill the Partial Requirement
for **Master's Degree** in **Computer Science**

Specialty: Network Information and Communication
Technologies (NICT)

Prepared By:

Laidi Islam,
Abdullaoui Mohammed

Supervised By:

Mouhoub Nasser Dinne
Samir Akhrouf

ENTITLED

**Design and implementation of a Mobile application for
a travel and tourism agency in Algeria**

Jury Members

Yagoubi Rached

President

Derdour Khadidja

Examiner

Academic Year 2023/2024

Dedication

*To the individual with a rich life story and enlightened mind, who was the first to impart to me higher knowledge (My beloved father, **rabeh**), may God grant him a long life.*

*To my dear mother **barkahm**, whose unwavering love and guidance have shaped my path and nurtured my soul, may God bless her with abundant health and boundless joy*

To my siblings;

Muhammad, Ayoub, Ishaq,
*and my sister **Khawla***

Whose companionship and support have been the pillars of strength through life's trials and triumphs.

To all my esteemed teachers;

Whose wisdom and dedication have illuminated my journey of learning and growth.

I dedicate my research to the pursuit of knowledge and the betterment of humanity,

In honor of the values instilled in me by my family and mentors,

And in gratitude for the opportunities they have afforded me to make a meaningful contribution to society...

Laidi Islam.....

Dedication

*"The journey of this research has been marked by numerous challenges,
yet through steadfast perseverance, determination, and resilience,
I have endeavored to surmount them, with profound gratitude to God.
I express heartfelt gratitude to my beloved parents, supportive siblings, and
cherished friends,
whose unwavering encouragement and assistance have been indispensable in the
completion of this significant research endeavor.
I am deeply indebted to my esteemed teachers, whose unwavering guidance,
mentorship and provision of invaluable insights have been paramount to my
intellectual and scholarly development...
With this comprehensive thesis, I offer profound insights and scholarly
contributions..."*

*May the Almighty bestow
blessings, and
prosperity, and grant them long, healthy, and
fulfilling lives*

Abdullaoui Mohammed

Acknowledgment

We wish to express our deep appreciation and gratitude to our distinguished guides, pr. Akhrouf Samir and pr Mouhoub Nasser Dinne., for their dedicated

efforts in guiding

and guiding us throughout this academic journey. We appreciate all the hard work and commitment you have shown to help us learn and grow.

We also extend our heartfelt thanks to our dear teachers, who shared their knowledge and experience and opened up new horizons in the world of learning.

We cannot forget the valuable role of our great parents who stood by us and supported us throughout this phase. You are a constant source of inspiration and support for us.

In addition, we thank our brothers, friends, and colleagues who have always been there for us and encouraged and supported us every step of the way. Your presence means a lot to us.

We sincerely appreciate everything you did for us. We have learned a lot from each of you and will always keep your memory close to our hearts.

Table of contents

List of figures	v
Introduction	1
1 Overview of Travel and Tourism Services in Algeria.	5
1.1 Introduction	5
1.2 Tourism Technology and Development.....	5
1.2.1 Social media	6
1.2.2 Web sites	6
1.3 Travel Agency	7
1.4 Trip	7
1.5 The role of travel agents	7
1.6 Tourism	8
1.7 Different types of tourism	8
1.7.1 Tourism by geographical region	8
1.7.2 Tourism by target	8
1.8 Tourism pillars	9
1.8.1 Tourism by target	9
1.8.2 Accommodation	9
1.8.3 Programs	9
1.9 The importance of tourism in Algeria	9
1.9.1 The economic importance of tourism.....	10
1.9.2 The social importance of tourism	10
1.9.3 The political importance of tourism.....	10
1.10 Tourism in Algeria.....	10
1.11 Tourist places in Algeria	11
1.11.1 The Maqam Echahid	11
1.11.2 Constantine	12

1.11.3	Al'at Bani Hammad	12
1.11.4	Wilāya Tamanrāssat	12
1.11.5	Bey's Palace	13
1.12	Conclusion	13
2	Identifying User Needs and Requirements.	14
2.1	Introduction.....	14
2.2	Needs analysis	14
2.2.1	Booking Flights ,Hotels and Cars.....	14
2.2.2	Tourism information and guidance	14
2.2.3	Customer Service	15
2.2.4	Offers and discounts.....	15
2.2.5	Organizing unique tourist experiences	15
2.3	Use cases	15
2.3.1	Status of use 01	15
2.3.2	Status of use 02	15
2.3.3	Status of use 03	16
2.4	Data modeling.....	16
2.4.1	Booking Data.....	16
2.4.2	Tourism Information Data	16
2.5	Study of global and local travel applications in Algeria	16
2.5.1	Limited content and services in global applications	17
2.5.2	Lack of local customer support.....	17
2.5.3	Challenges in Payment Methods and Currency	17
2.5.4	Compatibility Issues with Local Communication Networks.....	18
2.5.5	Limited Access to Local Offers and Discounts.....	18
2.6	Some similar applications	19
2.6.1	Safroye Travel and Tourism Guide Platform	19
2.6.2	Hopper.....	19
2.7	Conclusion	19
3	Application Design	20
3.1	Introduction.....	20
3.2	Pacestar UML Diagrammer.....	20
3.2.1	Use Case Diagram.....	20
3.2.2	Sequence Diagram	21
3.2.3	Class Diagram	21

3.3	Use Case Diagram	21
3.4	Sequence Diagram.....	23
3.5	Class Diagram.....	47
3.6	Conclusion	48
4	Implementation and dissemination of the application.	49
4.1	Introduction	49
4.2	HardWare.....	49
4.3	LATEX	50
4.4	StarUML.....	50
4.5	Flutter	50
4.6	Dart.....	51
4.7	Visual Studio	52
4.8	Android Studio.....	52
4.9	PHP	53
4.10	XAMPP	53
4.11	Hostinger.....	53
4.12	Implemented Technologies	55
4.13	The application interfaces	56
4.14	Conclusion	67
	Conclusion	68
	References	70

List of figures

1.1	Booking	7
1.2	Kayak	7
1.3	Maqam Echahid.....	11
1.4	Constantine	12
1.5	Al'at Bani Hammad	12
1.6	Tamanrāssat	12
1.7	Bey's Palace	13
2.1	Safroye	19
2.2	Hopper	19
3.1	Use Case Diagram.....	22
3.2	Sequence Diagram Sign up.....	23
3.3	Sequence Diagram Search Trip Planner	24
3.4	Sequence Diagram Search for hotels.....	25
3.5	Sequence Diagram Search for cars.....	26
3.6	Sequence Diagram Search for a guide.....	27
3.7	Sequence Diagram Book plane ticket.....	28
3.8	Sequence Diagram Book a hotel.....	29
3.9	Sequence Diagram Book a car.....	30
3.10	Sequence Diagram Book a Guide.....	31
3.11	Sequence Diagram Authenticate	32
3.12	Sequence Diagram Manage Hotels-Add.....	33
3.13	Sequence Diagram Manage hotel-edit.....	34
3.14	Sequence Diagram Manage hotel-delete.....	35
3.15	Sequence Diagram Manage car-Add.....	36
3.16	Sequence Diagram Manage car-edit	37
3.17	Sequence Diagram Manage car-delete.....	38

3.18	Sequence Diagram Manage Tourism agency-add.....	39
3.19	Sequence Diagram Manage Tourism agency-Withdraw	40
3.20	Sequence Diagram Manage Trip planner-add	41
3.21	Sequence Diagram Manage Trip planner-edit	42
3.22	Sequence Diagram Manage Trip planner-delete.....	43
3.23	Sequence Diagram Manage Guide-add	44
3.24	Sequence Diagram Manage Guide-edit.....	45
3.25	Sequence Diagram Manage Guide-delete	46
3.26	Class Diagram.....	47
4.2	Sign up	56
4.3	Cheek code	57
4.4	Change of language	58
4.5	State	59
4.6	Overview of tourist places in the states of Algeria	60
4.7	Book a ticket.....	61
4.8	Hotel reservation.....	62
4.9	to rent a car.....	63
4.10	Rent in a tourist agence	64
4.11	Administrator.....	65
4.12	Manage city-Add-Edit-Delete.....	66

General Introduction

Introduction

The world is witnessing significant technological progress in all sectors, thanks to information technology, which plays an important role in developing many companies and organizations. The most used internet service in new communication technologies is the web.

This service has become an exhibition for various companies around the world. It is a free trade area and a huge electronic market, which enhances the activity of these companies through what is known as e-commerce.

Travel Agencies is one of the organizations that need to provide its services online to its diverse customers. Its objective is to meet its customers' tourism and passenger transport needs by air and road within the country. Examples of its services include: Coordinate flight bookings with airlines, book hotels, offer tourist programs, and organize flights.

Enhancing the tourism sector in Algeria is a key strategic goal, as it can significantly contribute to local economic development and support cultural diversity. However, tourism in Algeria faces several challenges, including the lack of promotion for some tourist spots online, the absence of local tourism websites, and the reliance on traditional methods by travel agencies, which complicates and slows down service accessibility for customers.

Problems and Objectives

The Algerian tourism sector faces several challenges, including the underrepresentation of tourist destinations online, the absence of local tourism websites, and the traditional approach of providing travel services, which hampers accessibility and efficiency for customers.

To address these issues, our objectives are as follows:

- Develop a user-friendly tourism agency app to streamline customer interactions and ensure quick access to online resources.
- Enhance accessibility by offering a range of services, including hotel searches, car rentals, flight bookings, and tourism programs, tailored to user preferences.
- Promote Algerian tourism by leveraging the application to disseminate information and services related to the country's tourist sites and attractions.

By tackling these challenges and pursuing our objectives, we aim to revolutionize the Algerian tourism landscape, making it more accessible, efficient, and appealing to both domestic and international travelers.

Motivation

- Strengthen Algeria's tourism sector by providing a modern and effective way to promote tourist destinations and facilitate bookings.
- Meet customers' aspirations and improve their experience by providing convenient and easy access to travel and tourism services.
- Support the Algerian State's efforts to promote local tourism and attract more visitors by raising awareness of tourism destinations and providing a means for booking and utilizing available services.

Similar applications and differences:

- Application "Tourists in Algeria

- Focuses on providing information and services for domestic tourism within Algeria in a specialized and targeted manner.
- Available in local languages such as Arabic and international languages such as English to ensure effective communication with both local and foreign users.
- Includes detailed information on Algerian attractions, culture, and history.
- Offers local services such as hotel bookings, restaurants, and inland transportation in Algeria,

making it easier for tourists to organize their trips.

- Promotes awareness of local tourism and encourages support for the local economy by enhancing interest in domestic tourism destinations.

- Universal Application

- Targets global tourism generally without focusing on a specific tourist destination, which does not allow users to obtain specific and accurate information about local destinations.
- Available in English, which may not be easily accessible and understandable for local users.
- Engages with global and local companies to meet global travel, accommodation, and transportation needs.
- Encourages the exploration of many international tourist destinations in general, most of which are the world's famous tourist attractions, making them less accurate for local needs.

The tourism application in Algeria helps meet the needs of domestic and international tourists wishing to explore tourist destinations in the country comprehensively and accurately, thereby contributing to promoting local tourism and supporting the local economy.

Proposed Solution

We propose a tourism application designed to meet the needs of travelers in Algeria. Offering easy access to information, users can efficiently book excursions, hotels, and rental cars online, thus saving valuable time and effort. Our application ensures a seamless experience through convenient browsing and detailed information on tourist destinations across Algeria.

For clients, our application offers the convenience of easily booking flights and hotels, along with efficient management of bookings. Users also gain access to comprehensive destination information and exclusive offers, enhancing their travel experience.

Administrators have access to powerful tools for managing hotels, agencies, car rental companies, and tour guides seamlessly. They can oversee all bookings, analyze performance data, and adjust permissions, ensuring smooth operation and exceptional service delivery.

Through the proposed solution, we aim to revolutionize tourism in Algeria, providing travelers with a user-friendly mobile app that meets all their needs, from booking to exploring the country's rich cultural and natural heritage.

Methodology

The development of our proposed tourism mobile application for Algeria followed a structured methodology encompassing several essential phases: research, design, development, and evaluation. Initially, we conducted thorough market research and analyzed user requirements to gain insights into potential users' needs and identify critical features. This process involved examining similar international and local applications, as well as gathering feedback through surveys and interviews. Based on this research, we crafted the system architecture and user interface, prioritizing scalability, security, and user experience.

In the development phase, we utilized cutting-edge technologies to build the front end of the mobile application, aiming for an intuitive and captivating user interface. Backend services were developed to efficiently handle business logic, data management, and party integrations. Extensive testing, including unit tests, integration tests, and user acceptance tests, was conducted to ensure the application's functionality and reliability.

Upon deployment to a live environment, ongoing monitoring and maintenance are planned to promptly address any issues and incorporate user feedback. This approach aims to deliver a robust and user-friendly mobile application that effectively showcases Algerian tourist destinations and facilitates seamless bookings and travel management for users.

Dissertation Structure

This dissertation is structured into the following chapters:

- **Chapter 1:** Overview of Travel and Tourism Services in Algeria.

The chapter discusses the importance of tourism in Algeria, highlighting challenges and opportunities to strengthen the sector.

- **Chapter 2:** Identifying User Needs and Requirements.

This chapter identifies the requirements for users to design an app that meets their expectations and solves their problems.

- **Chapter 3:** Application Design.

The chapter displays the structure and design of the application using UML technology.

- **Chapter 4:** Implementation and dissemination of the application.

This chapter reviews the process of developing and testing the application to ensure its quality and effectiveness and reviews the interface.

Chapter 1

Overview of Travel and Tourism Services in Algeria.

1.1 Introduction

Today, tourism is one of the most important areas in the world. Tourism has become a cultural and social industry. It is the main center of activity for services and One of the world's rapidly developing sectors. It is an effective means of achieving sustainable development, reducing economic and social gaps, and ensuring the sustainability of resources. Some countries like the Maldives and Germany even exceed tourism spending in their total commodity exports.

Tourism also contributes to the creation of many jobs and stimulates the local economy. It is an effective way to exchange cultures and promote global understanding. Tourism is a means of entertainment to improve mental and physical health.

People can relax and enjoy their time in beautiful natural environments or experience different activities. In addition, tourism helps broaden people's perspectives and increase their knowledge and culture.

1.2 Tourism Technology and Development

Technology has had an enormous impact on tourism and "has made tourism an interactive and effective industry.

It has contributed to improving the tourist experience in several ways. Technology helps plan and manage flights, provides aerial and climatic data, facilitates flight scheduling, and also enhances tourist safety and digital payment has facilitated transactions. In addition,

tourism companies have grown and become able to market more effectively.

According to experts, digital technology has brought many benefits to tourism such as:

- Make travel more convenient (one- click payment, use booking platforms, evaluation sites, etc.)
- Enhanced security through security features such as GPS
- Easy database management (e.g., hotel management software, visual tours)
- Expanding actors: Social media marketing, for example, allows service providers to identify themselves at a global level and at a low cost

Below are the main information and communication technologies and their role in promoting and advertising tourism.

1.2.1 Social media

Social media is one of the important promotional tools for the development of economic, social, and political benefits of the tourism sector and has allowed a rapid increase in the presentation of images in a more exciting and effective way, Because social media users are all segments of society, making advertising one of the most important and effective marketing means. With the information revolution and technological development that has engulfed the world, tourism is not only recreational and entertaining, but also an industry with its objectives and dimensions in the economy of many countries of the world and an instrument of culture in developed societies.

Videos of a group of social media influencers, who are in turn considered Algerian tourists and travelers such as Khabib and Arabs such as Al-Masri Mahmoud Hijazi, were recently joined by travelers from around the world Joe Hatab, describe, promote and introduce tourist areas in Algeria that have impressed them, highlighting the importance of social media sites in promoting tourism.

1.2.2 Web sites

Many websites have helped to promote tourism, facilitate the organization of tourist visits, explore tourist areas, provide the necessary information on targeted areas, and allow reservations.

The most important of these sites are:

Booking

Booking is an intelligent website as it is the best website for hotel bookings around the world and also started booking flights at suitable prices.[5]



Fig. 1.1 Booking

Kayak

Kayak is one of the best locations, with prices on full packages, restaurants, cruises, hotels, flights and car rental that is to say, it has in most services.[12]

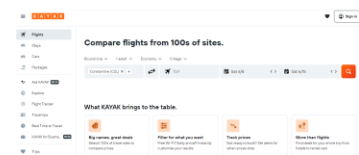

Fig. 1.2 Kayak

1.3 Travel Agency

The travel agency provides advice, creates, organizes and sells individual trips. It is the broker between customers and various tourism actors:

Air and sea companies, tour operators, hoteliers, car rental companies, insurance... etc.[1]

1.4 Trip

The trip is a trip from one place to another, usually at a large distance, made for a specific purpose. The trip can involve different means of transport such as car, train, plane or boat.

1.5 The role of travel agents

- Receive customers and provide advice and advice.
- Contact third parties (accommodation booking, flights, etc.).
- Support the client's administrative procedures.
- Monitoring and customer satisfaction.

The role of the travel agency is not only to sell services, but also brings added value through direct contact with tourists, including providing informational tasks and advisory

functions on travel conditions and precautions. (Passport validity, visa requirements, driver's license (if required in a car reservation)).

1.6 Tourism

Tourism refers to travel activity or visiting places outside the usual residence, for entertainment, discovering new places, or experiencing different experiences.

Tourism also includes travel-related economic activities, such as transportation, accommodation, catering, guided tours, and leisure activities. These may be flights to national or international destinations that vary in duration and purpose. [13]

1.7 Different types of tourism

It is divided into: [14]

1.7.1 Tourism by geographical region

- Domestic tourism: means the travel of nationals of the State within their country's borders.
- Regional tourism: Tourism in which tourists move between neighboring countries is one tourist area. Like the Arab countries and the European Union.
- Foreign tourism: It is the movement of tourists from one country to another for tourism and it is temporary.

1.7.2 Tourism by target

- Religious Tourism: This type of tourism consists of visiting religious sites in the world. Makkah is one of the most popular religious sites in the world. Thousands of Muslims invoke it in the Hajj season every year. The Saudi General Authority for Statistics estimated the total number of pilgrims for the Hajj season 1439 AH (2017-2018) at 2.371.675.
- Hospital tourism: relocation to therapeutic tourist places with natural elements 2 for treatment of certain diseases.
- Ecotourism: a tourist activity aimed at visiting nature reserves and preserving the cultural, environmental, and natural heritage of the areas visited, where these tourist legacies are part of the environment.

- Leisure tourism: a type of tourism that includes leisure and enjoyment travel, participation in various recreational activities such as fishing, and usually extends over short periods.
- Conference tourism: refers to the organization and holding of conferences on a large scale and globally. It is considered an influential area in the tourism sector, where it generates significant profits and effectively contributes to tourism development.

1.8 Tourism pillars

Tourism Pillars Group: * Transport

1.8.1 Tourism by target

Enhancing transport infrastructure is vital for the advancement of tourism. The tourism sector heavily relies on the development of efficient transport systems, which encompass various modes:

- Road transport.
- Means of shipping.
- Means of air transport.

1.8.2 Accommodation

Accommodation encompasses diverse facilities where tourists can stay temporarily upon reaching their destination. This includes campsites, hotels, and tourist apartments among other options.

1.8.3 Programs

Tourist itineraries are structured around specific programs designed to enhance the visitor's experience. These programs typically involve activities such as recreational areas, archaeological sites, and historical landmarks. Additionally, tourists often explore parks, markets, and shops. [13]

1.9 The importance of tourism in Algeria

he importance of tourism: [19]

1.9.1 The economic importance of tourism

- Promoting economic growth: The tourism sector represents an opportunity to diversify national sources of income and stimulate economic growth by increasing fiscal revenues flowing from tourism.
- Job creation: The tourism sector is an important source of direct and indirect job creation in hotels, restaurants, and other tourism services, thereby contributing to lower unemployment rates.
- Promotion of investments: Interest in tourism encourages investments in tourism infrastructure such as hotels, resorts, and attractions, which contributes to improving infrastructure and increasing tourism attractiveness.

1.9.2 The social importance of tourism

- Promotion of cultural understanding: tourists contribute to promoting understanding and communication between different cultures by exchanging experiences and experiences.
- Protection of heritage and culture: Increased interest in tourism encourages the preservation of Algeria's cultural and historical heritage and the promotion of awareness of its importance.
- Promoting environmental awareness: Tourism can contribute to promoting environmental awareness and conserving natural resources by focusing on ecotourism and sustainability.

1.9.3 The political importance of tourism

- Enhancing the international image: Tourism can play an important role in enhancing Algeria's international image as an attractive and diverse tourist destination.
- Strengthening international relations: tourists promote international and cultural relations between Algeria and the rest of the world, thereby contributing to the promotion of international understanding and cooperation.

In short, tourism plays an important role in promoting Algeria's economic, social, and political development and contributes to promoting cultural understanding and cultural exchange among people.

1.10 Tourism in Algeria

Since independence, Algeria has endeavored to promote the tourism sector, starting with the Tourism Charter of 1966, and then including tourism in development schemes. to make the tourism sector a wealth-generating sector and to upgrade Algeria's tourism

product the Algerian State is currently seeking to strengthen the tourism sector and give it the real place Tourism Development Plan 2010 ", which was finalized in 2000 under the title " Tourism Sector Development Plan 2010 ", was launched by the Ministry of Wills in 2001 "A blueprint for the sustainable development of tourism in Algeria" 2010 " and two years after the implementation of this scheme, it is necessary to make some adjustments to stabilize gains and set prospects, To keep pace with new developments internally and externally, a new project called Horizons 2013, The Tourism Planning 2025 also reflected and translated the State's effective and genuine management in making tourism a national priority. s new tourism strategy in the short, medium, and long term within the framework of sustainable development. [8]

1.11 Tourist places in Algeria

Algeria, situated in North Africa, is a land rich in history, culture, and natural beauty. Here's a brief introduction to some of its prominent tourist destinations: [2]

1.11.1 The Maqam Echahid

The Maqam Echahid (, Maqāmu š-šahīd, Arabic pronunciation English: Martyrs' Memorial) is a concrete monument commemorating the Algerian War. The monument was opened in 1982, on the 20th anniversary of Algeria's independence. It is fashioned in the shape of three standing palm leaves, which shelter the "EternalFlame" under it.

At the edge of each palm leaf is a statue of a soldier representing a stage of Algeria's struggle for independence.



Fig. 1.3 Maqam Echahid

1.11.2 Constantine

Constantine (Qasant, inah") is the capital of the province of Constantine in northeastern Algeria.

During Roman times it was called Serta and renamed "Constantine" in honor of the great Emperor Constantine.

Constantine was named the capital of Arab culture in 2015.



Fig. 1.4 Constantine

1.11.3 Al'at Bani Hammad

Al'at Bani Hammad , also known as Qal'a Bani Hammad or Qal'at of the Beni Hammad, is a historic fortified palatine city located in Algeria. It was the first capital of the Hammadid dynasty during the 11th century. Situated in the Hodna Mountains northeast of M'Sila, the site sits at an elevation of 1,418 meters (4,652 ft) and benefits from ample water sources originating from the surrounding mountains. Al'at Bani Hammad is situated near the town of Maadid (also known as Maadhid), approximately 225 kilometers (140 mi) southeast of Algiers in the Maghreb region. Today, the site remains in ruins, offering a glimpse into the historical significance of the Hammadid dynasty and the architectural heritage of the region.



Fig. 1.5 Al'at Bani Hammad

1.11.4 Wilāya Tamanrāssat

Tamanrasset is the largest province (wilaya) in Algeria, named after its principal city, Tamanrasset. It encompasses an expansive area of 557,906 km², making it the largest province in the country. Tamanrasset province is notable for housing two national parks—Tassili n'Ajjer National Park and Ahaggar National Park—more than any other province in Algeria. The region is characterized by the majestic Hoggar Mountains or idurar n Ahaggar, a vast highland area situated in the central Sahara along the Tropic of Cancer. Covering approximately 550,000 km², the Hoggar Mountains are renowned for their stunning landscapes and unique geological formations.



Fig. 1.6 Tamanrāssat

1.11.5 Bey's Palace

Bey's Palace in Oran, Algeria, is a historic Ottoman-era palace dating back to the 18th century. Commissioned by Muhammad Bey the Great, it served as the residence of the ruler of the Western Beylik. The palace, located near Mount Marjaju in Sidi al-Houari, spans approximately 5.6 hectares and is recognized as a national heritage site. It comprises various sections including a diwan (public room), suite, harem, Marinid-era guard towers from 1345, barracks used as a horse stable by both Ottomans and French, and a courtyard. Today, Bey's Palace is a popular tourist attraction, highlighting Algeria's Ottoman history and architectural heritage.



Fig. 1.7 Bey's Palace

1.12 Conclusion

This chapter provides a comprehensive overview of the travel and tourism landscape in Algeria, emphasizing its transformative impact on the economy, society, and international relations. It underscores the importance of strategic development and promotion to position Algeria as a prominent destination for global travelers.

Chapter 2

Identifying User Needs and Requirements.

2.1 Introduction

The tourism industry plays a crucial role in promoting economic growth and cultural exchange in Algeria. To enhance the country's attractiveness and competitiveness as a tourist destination, travel agencies need to understand and meet the diverse needs of tourists.

By focusing on the areas of booking flights and hotels, information and tour guidance, customer service, offers and discounts, and unique tourism experiences, travel agencies can ensure a seamless and unforgettable experience for their customers.

2.2 Needs analysis

2.2.1 Booking Flights, Hotels and Cars

Customers look forward to an easy-to-use system for booking airline tickets, hotel bookings, and renting cars at competitive and acceptable prices.

2.2.2 Tourism information and guidance

Visitors are expected to provide comprehensive information about tourist destinations in Algeria, including available activities, with guidance and maps to facilitate mobility.

2.2.3 Customer Service

Customers need a direct and effective support system to help with problems or inquiries.

2.2.4 Offers and discounts

Customers expect attractive and rewarding offers and discounts on flight bookings, hotels, and car rentals to enhance the agency's attractiveness and achieve financial savings.

2.2.5 Organizing unique tourist experiences

Visitors search for dedicated tourist programs and unique experiences that meet their needs and desires, such as excursions and cultural trips that reflect the country's culture and history.

2.3 Use cases

2.3.1 Status of use 01

Book a tourist trip Steps:

- The user is looking for a specific tourist destination.
- Select preferred travel dates and number of accompanying people.
- Compare options for flight and flight packages.
- Selects the best option and makes the final reservation.

Note:

The user can update or cancel the booking in accordance with the cancellation policy specified by the travel agency.

2.3.2 Status of use 02

Search for tourist information

Steps:

- The user begins to search for information about the designated tourist sites.
- The user receives detailed information about the selected tourist sites and available activities.

2.3.3 Status of use 03

Communicate with Customer Service

Steps:

- The user has difficulties in the booking process or has inquiries.
- Contact the customer service team through the app for help and support.

2.4 Data modeling

2.4.1 Booking Data

- Includes flight details such as dates, destination, and number of people traveling.
- Reserved hotel information including the hotel name and booking details is recorded.

2.4.2 Tourism Information Data

- Contains comprehensive information about the tourist destinations and activities are available in each destination.
- Also include information on recommended hotels in each destination to meet travelers' needs.

2.5 Study of global and local travel applications in Algeria

Developing global travel apps has made it easier for people to plan and organize their journeys. However, in Algeria's case, these apps may lack customized content and services, leading to fewer options for travelers. In return, local travel requests in Algeria offer advantages such as custom content and local customer service. This article explores the challenges that global applications face in meeting the specific needs of Algerian travelers and the benefits offered by local applications. [19]

2.5.1 Limited content and services in global applications

Global travel applications may not provide sufficient content and services dedicated to travel in Algeria. Algeria's unique cultural heritage, historical sites, and landscapes offer a rich and diverse tourist experience. However, global applications, which focus mainly on popular tourist destinations, may overlook Algeria's less well-known regions. This limited content and lack of detailed information can restrict options for travelers wishing to explore the country. For example, the global app may provide general information about major cities such as Algiers and Oran but fails to provide insights into less explored areas such as Mantrast or Tebaza. As a result, travelers who rely solely on global applications may lose unique experiences in Algeria.

2.5.2 Lack of local customer support

One of the challenges that global travel applications face in meeting Algerian travelers' needs is the lack of support for specialized local customers. Algeria's diverse cultural and linguistic landscape requires enhanced customer support that understands the specific needs and preferences of Algerian travelers. Global applications, with their limited local presence, may have difficulty providing satisfactory support to customers in Algeria. This can lead to unsatisfactory experiences for customers when users experience problems or need help while traveling. In contrast, domestic travel requests in Algeria can offer customized support to local customers, ensuring immediate assistance and personal service. Supporting local customers can guide travelers in making informed decisions, address language barriers, and make recommendations based on local knowledge.

2.5.3 Challenges in Payment Methods and Currency

Global applications may face challenges in supporting local payment methods and the use of local currencies in Algeria. Algeria has its payment ecosystem, with specific local payment gateways, banking systems, and digital wallets. Global applications, designed to cater to a wide range of countries, may encounter difficulties in integrating with Algeria's local payment infrastructure. This can lead to problems with payments, money transfers, and financial transactions for Algerian users. Domestic travel applications, being specifically tailored for the Algerian market, can offer seamless integrations with local payment methods, ensuring smooth and reliable transactions for travelers. Local payment support enhances convenience and trust in the payment process, contributing to a satisfactory user experience.

2.5.4 Compatibility Issues with Local Communication Networks

Another challenge faced by global travel applications in Algeria is compatibility with the country's local communication networks. Algeria has a diverse range of communication networks, including mobile networks, internet service providers, and Wi-Fi hotspots. Global applications, especially those developed by companies based in different regions, may not fully optimize their platforms for Algeria's networks. This can result in slower app performance, connectivity issues, and reduced responsiveness. On the other hand, domestic travel applications, developed and tested within the Algerian market, are more likely to be optimized for local network conditions, ensuring faster and more reliable performance. This compatibility advantage enables users to access information and services without disruptions, leading to a smoother user experience.

2.5.5 Limited Access to Local Offers and Discounts

Global applications may restrict access to local offers and discounts available in Algeria. Many local businesses and service providers in Algeria offer exclusive deals and discounts to attract domestic travelers. However, these offerings may not be readily available or prominently highlighted on global travel applications. As a result, users relying solely on global applications may miss out on the best deals and offers available in Algeria. Domestic travel applications, being more integrated within the local tourism industry, can provide comprehensive information on local offers, ensuring that users have access to the best available deals. This advantage allows travelers to make the most of their budget and benefit from exclusive local discounts.

2.6 Some similar applications

2.6.1 Safraway Travel and Tourism Guide Platform

Safraway is a European Emirati company founded in 2018, offering valuable and comprehensive tourist information about different tourist destinations and the best attractions to visit around the world. [16]



Fig. 2.1 Safraway

2.6.2 Hopper

It is one of the ideal flight dates indicative apps if you don't know what the perfect time is to buy your plane tickets will be very perfect for you.

Hopper expects price fluctuations for air travel day by day precisely as it also notifies you all the time about the tickets you want to buy and the right times. Hopper relies on analyzing the prices of millions of tickets for flights around the world and expecting the best time a user can book a flight ticket. [10]



Fig. 2.2 Hopper

2.7 Conclusion

By meeting the main needs of tourists in Algeria, travel agencies can create an exceptional tourist experience and contribute to the growth of the country's tourism industry. It is important to provide an easy-to-use system for booking flights and hotels, provide comprehensive tourist information and guidance, create a reliable system to support customer service, offer special offers and discounts, and offer unique tourist experiences.

By investing in these areas, travel agencies can distinguish themselves in the market and attract a variety of tourists looking for unforgettable experiences in Algeria.

Chapter 3

Application Design

3.1 Introduction

Before realizing the smartphone application, it is necessary to adopt a systematic and precise approach to the planning and design of the application, highlighting all the objectives that were followed for the proper development of the desired project.

The main purpose of mobile is to serve its users, so it is necessary to understand the desires and needs of future users. The development process will therefore be user-centered and these needs can be identified through analysis and design activities.

In this chapter, we will conduct a detailed analysis highlighting the different actors involved in the application and, based on the results of the analysis phase, the design phase will provide a modeling of the objectives to be achieved. To do this, we will rely on the UML modeling language that allows us to correctly represent the application dynamics through a series of graphs.

3.2 Pacestar UML Diagrammer

Allows you to create diagrams in UML You can insert hyperlinks to other diagrams and external files. It can work using a system of [17] drag and drop:

3.2.1 Use Case Diagram

The status of use chart is a diagram showing the relationships between users and the system being designed. Below we will show the status of the use chart of our application.

[6]

3.2.2 Sequence Diagram

A relay chart, sequence chart, or sequence diagram is one type of category chart in the uniform modeling language (UML) and shows the interaction between elements during a chronological sequence and depicts objects and items (classes) that are included in a particular software scenario and the sequence of messages exchanged between objects to properly execute the scenario. [18]

3.2.3 Class Diagram

Classes are a very important part of UML, a structural blueprint tasked with presenting categories in a particular system with all their relationships. After completing the determination of each user's role and their representation in the previous schemes, the following chart shows the information we need we build the database of the application.[4]

3.3 Use Case Diagram

The use case diagram illustrates how visitors, clients, and administrators interact with the tourism system. Visitors can log in and read news, while clients can search and book hotels, cars, flights, and tour guides, as well as manage their bookings. Administrators have full permissions to manage the system, including adding, modifying, and deleting data related to hotels, cars, trip planners, travel agencies, and tour guides. The diagram highlights all essential operations and delineates the roles of each user type to ensure the system's organization and smooth operation.

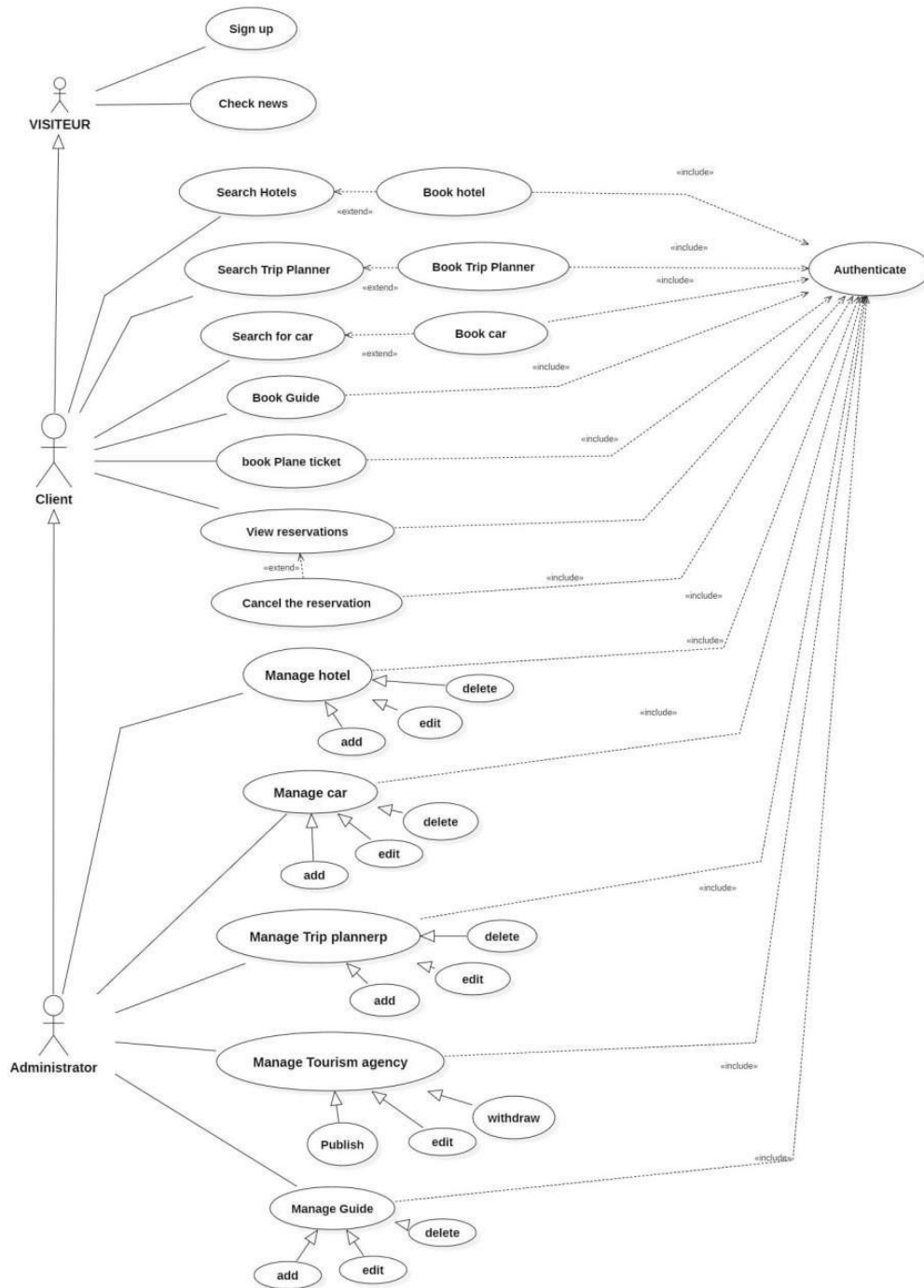

Fig. 3.1 Use Case Diagram

3.4 Sequence Diagram

Sequence Diagram Sign up

This sequence diagram details the process of a user signing up for the application, showing the interactions between the user and the system components involved in the signup process

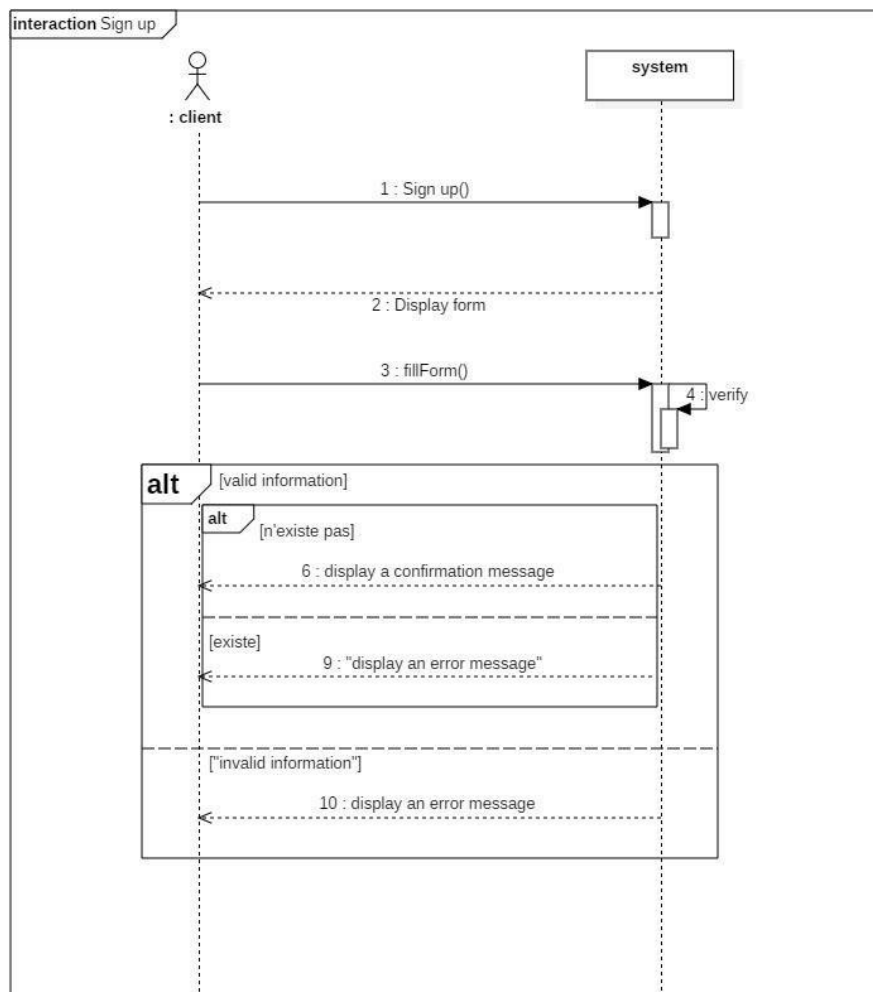

Fig. 3.2 Sequence Diagram Sign up

Sequence Diagram Search Trip Planner

This sequence diagram outlines the "Search Trip Planner" process where a client interacts with the system to find a trip planner. The system validates the provided information, presents search results.

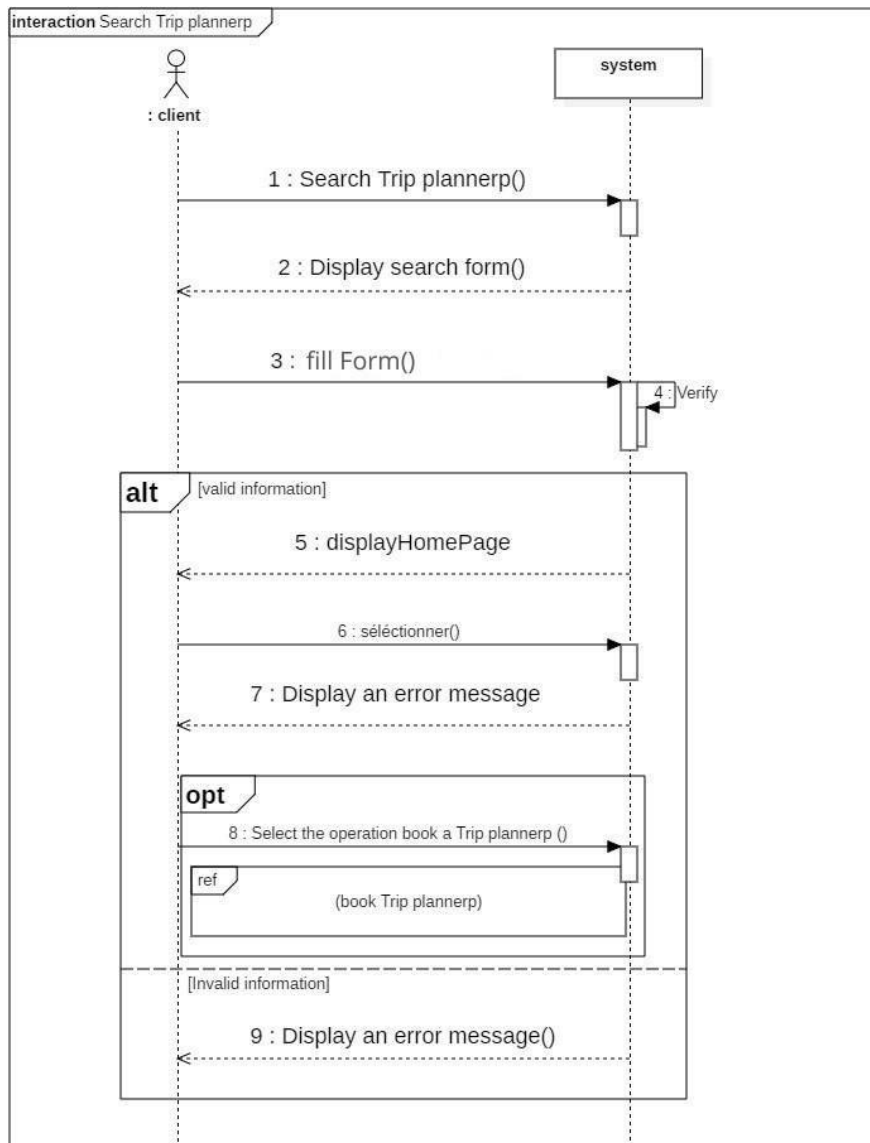

Fig. 3.3 Sequence Diagram Search Trip Planner

Sequence Diagram Search for hotels

This diagram depicts the sequence of actions and messages exchanged when a user searches for hotels. It includes interactions with the hotel database and the user interface.

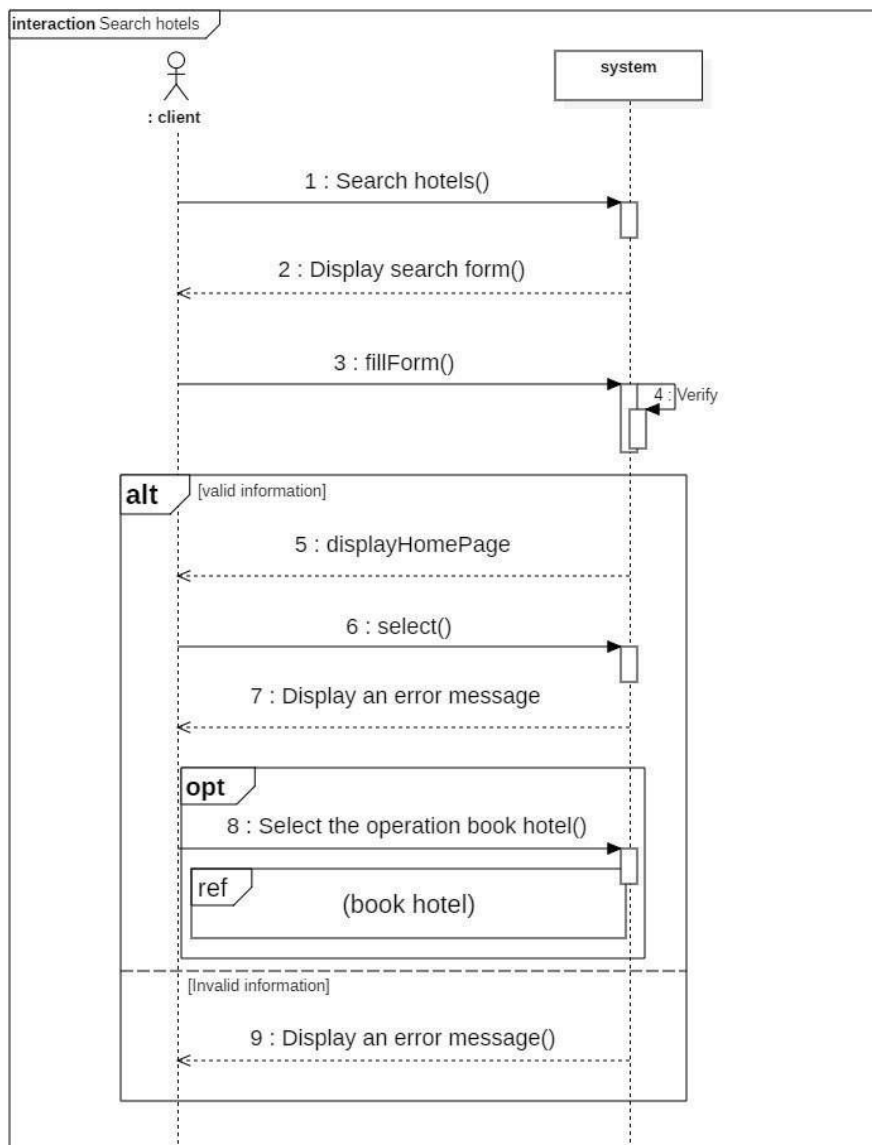

Fig. 3.4 Sequence Diagram Search for hotels

Sequence Diagram Search for cars

This diagram depicts the sequence of actions and messages exchanged when the user searches for cars. It includes interactions with the automotive database and user interface.

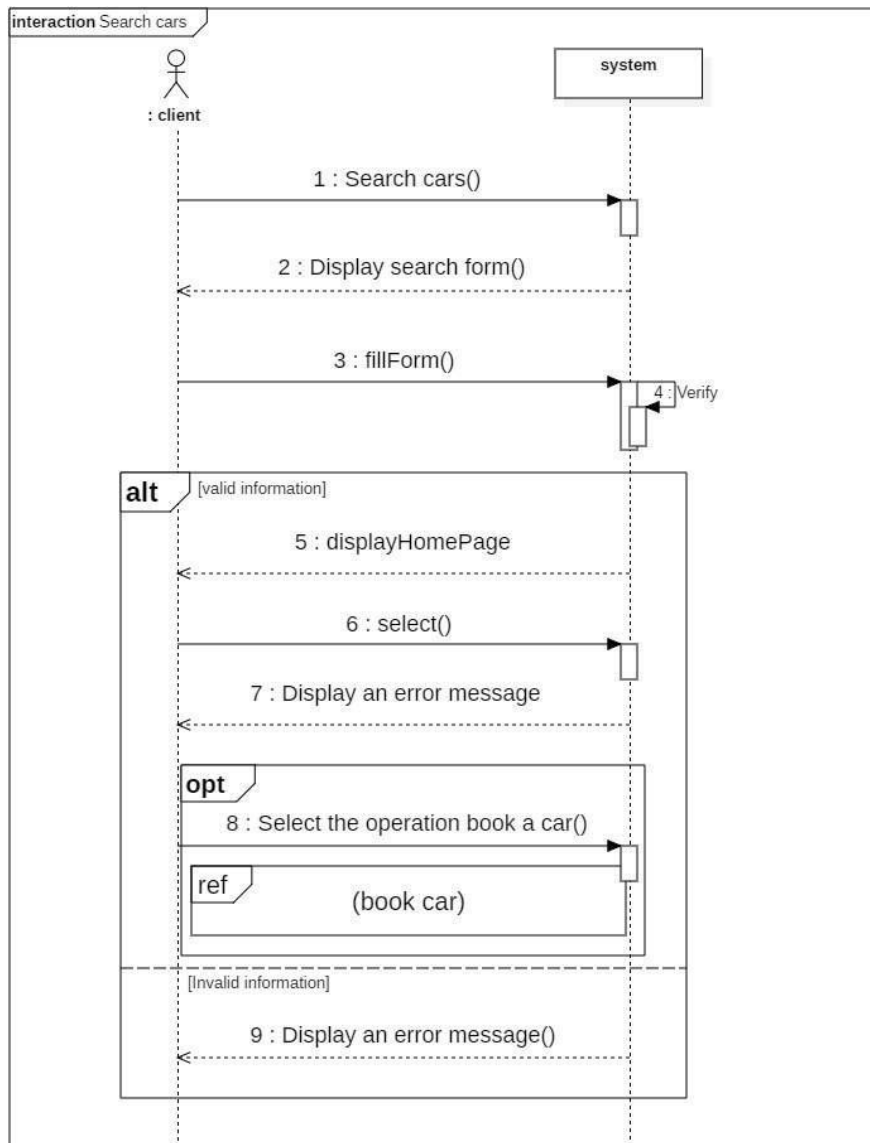

Fig. 3.5 Sequence Diagram Search for cars

Sequence Diagram Search for a guide

This diagram depicts the sequence of actions and messages exchanged when the user searches for a guide. It includes interactions with the guides database and user interface.

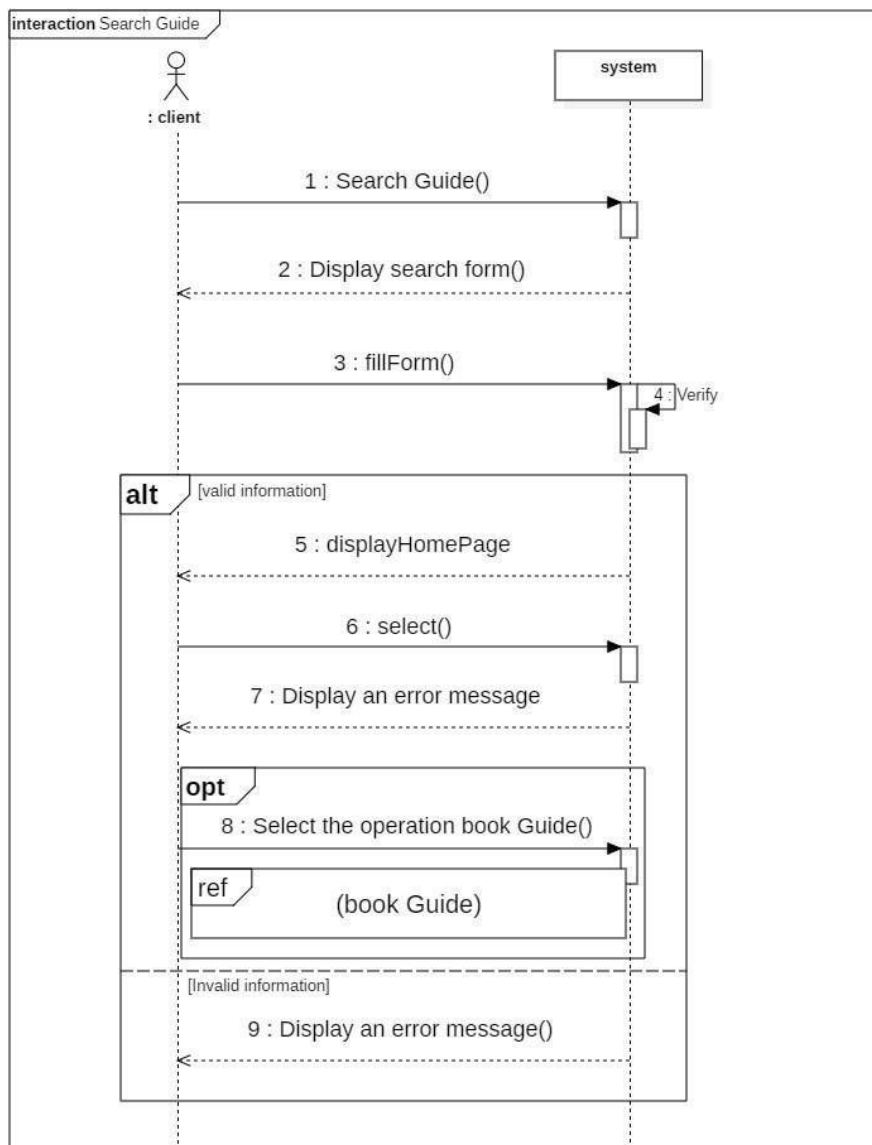

Fig. 3.6 Sequence Diagram Search for a guide

Sequence Diagram Book plane ticket

This diagram shows the steps involved in booking a plane ticket through the application, including interactions between the user, the booking system, and the payment gateway.

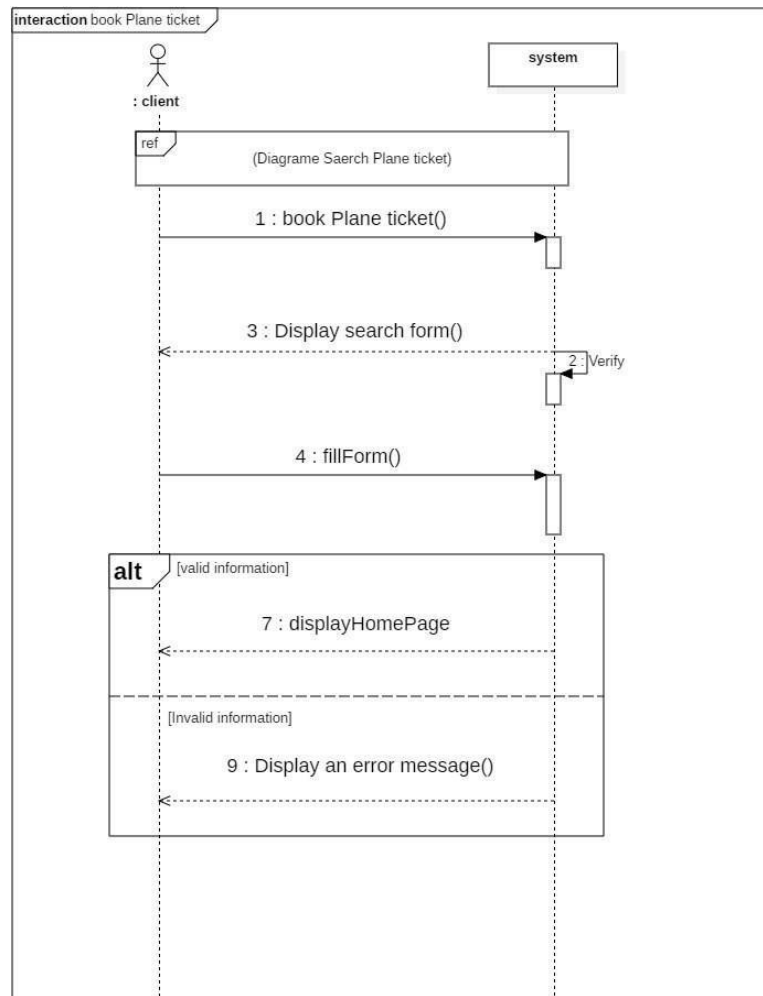

Fig. 3.7 Sequence Diagram Book plane ticket

Sequence Diagram Book a hotel

This diagram outlines the process of booking a hotel room, highlighting the interactions between the user, the hotel booking system, and the confirmation process.

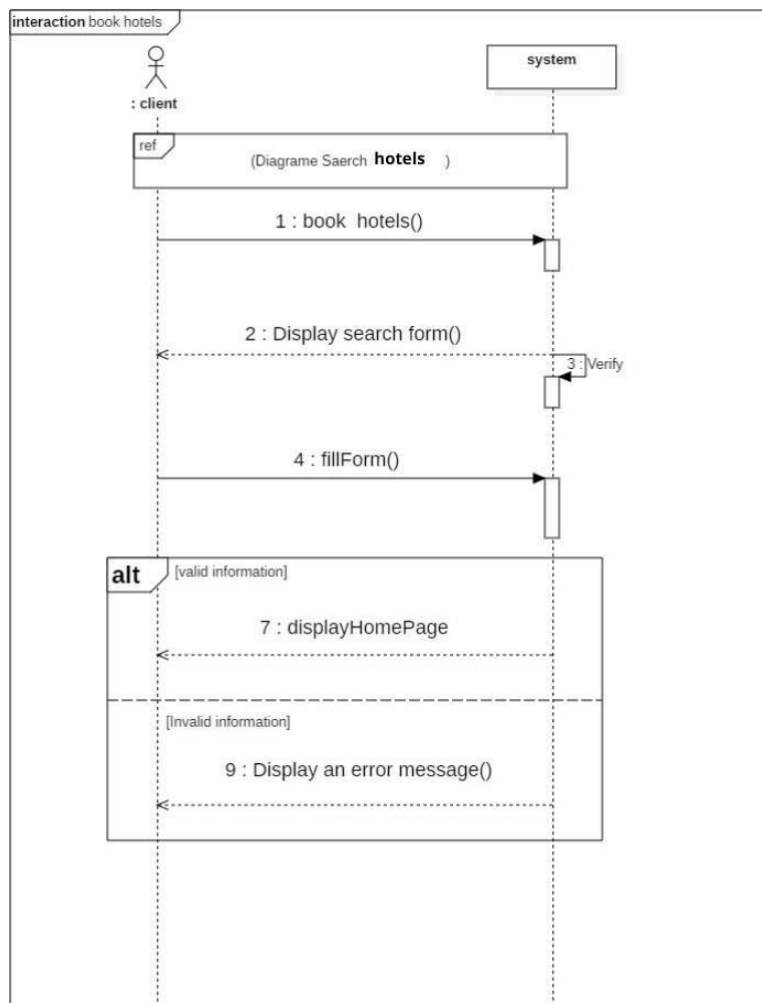

Fig. 3.8 Sequence Diagram Book a hotel

Sequence Diagram Book a car

This sequence diagram demonstrates the procedure for booking a car, showing how the user interacts with the car rental system to complete the booking.

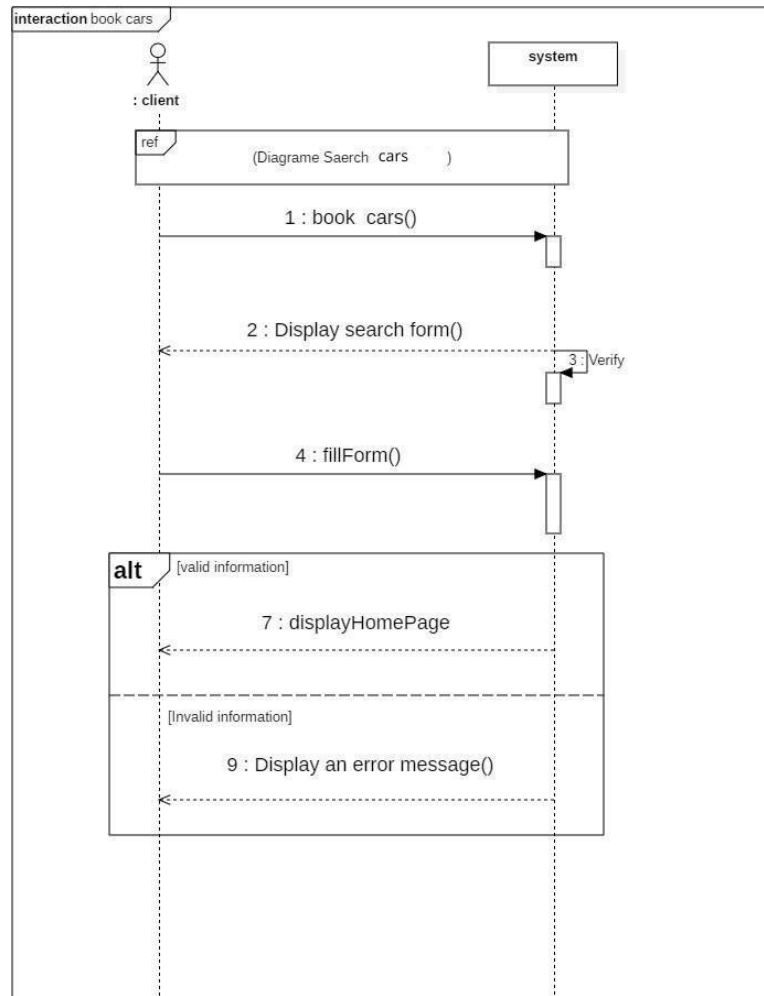

Fig. 3.9 Sequence Diagram Book a car

Sequence Diagram Book a Guide

This diagram illustrates the steps a user takes to book a tour guide, including the interaction between the user, the guide booking system, and the scheduling process.

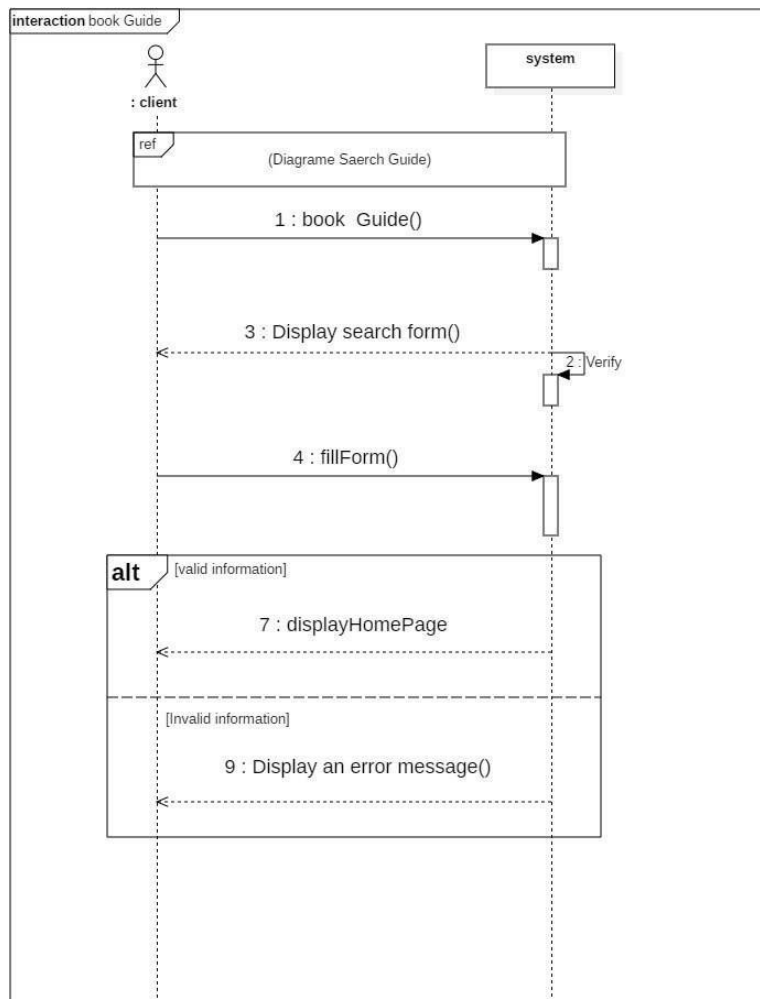

Fig. 3.10 Sequence Diagram Book a Guide

Sequence Diagram Authenticate

This diagram shows the authentication process where a user logs into the application, detailing the interactions between the user, authentication service, and the user database.

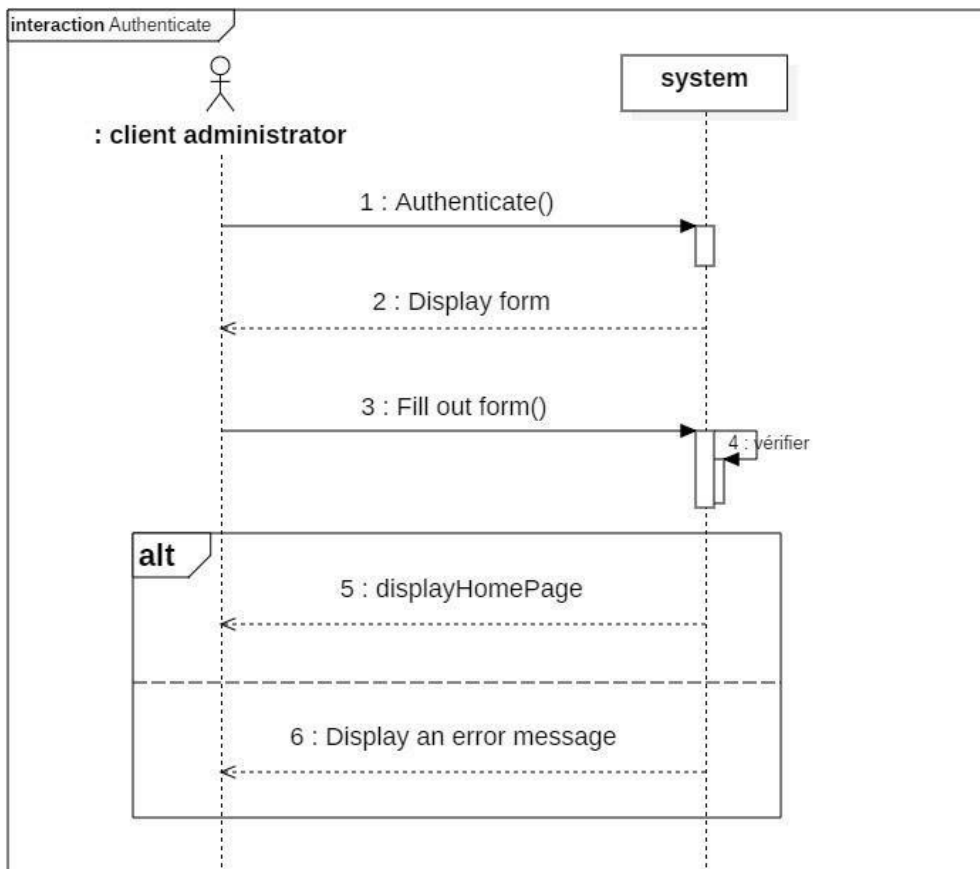

Fig. 3.11 Sequence Diagram Authenticate

Sequence Diagram Manage Hotels-Add

This diagram depicts the process of adding a new hotel to the system by an administrator, including interactions with the hotel database and the admin interface.

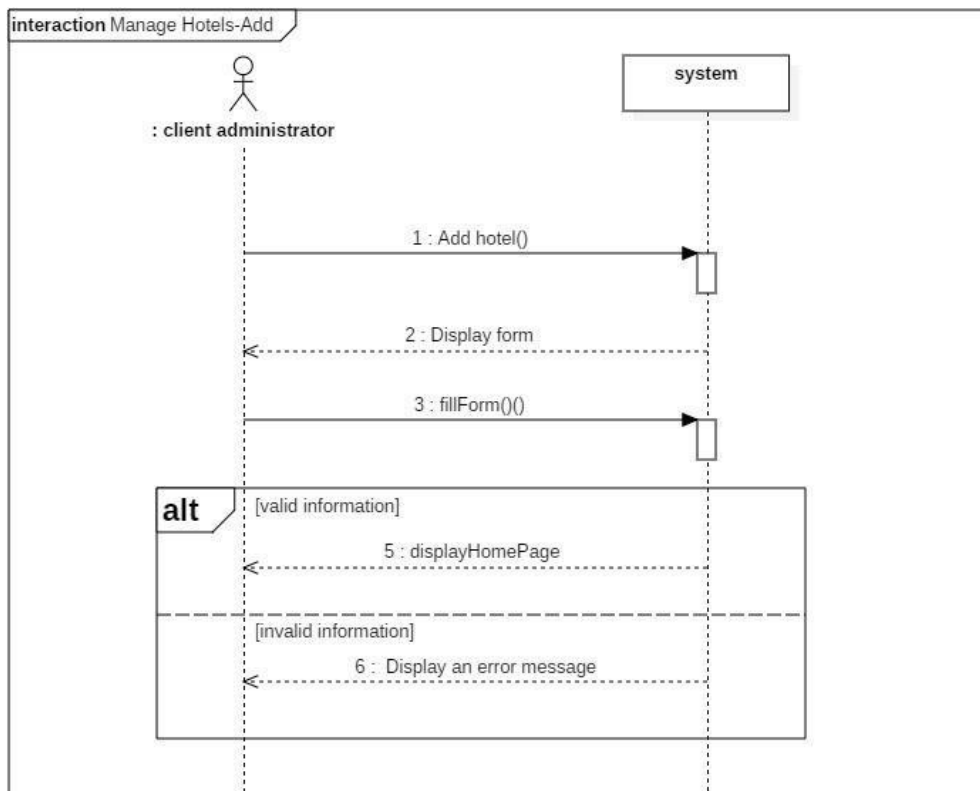

Fig. 3.12 Sequence Diagram Manage Hotels-Add

Sequence Diagram Manage hotel-edit

This sequence diagram details the steps taken by an administrator to edit existing hotel information in the system.

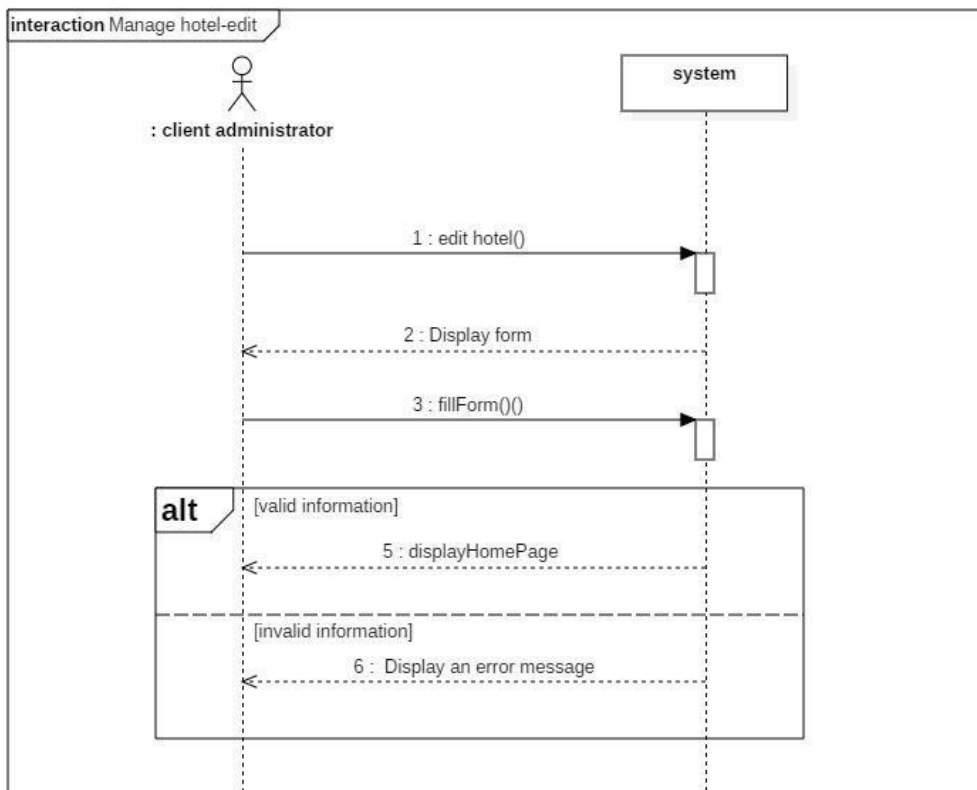

Fig. 3.13 Sequence Diagram Manage hotel-edit

Sequence Diagram Manage hotel-delete

This diagram shows the process of deleting a hotel from the system, highlighting the interactions between the administrator and the hotel database.

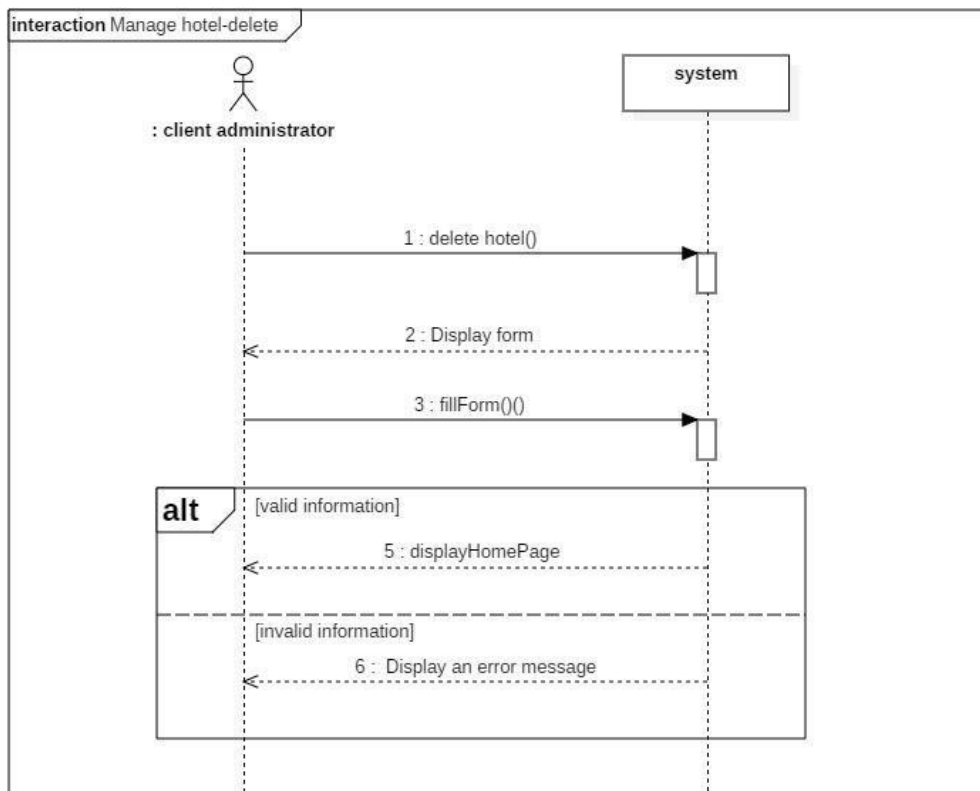

Fig. 3.14 Sequence Diagram Manage hotel-delete

Sequence Diagram Manage car-Add

This diagram illustrates the process for an administrator to add a new car to the rental system, showing interactions with the car database.

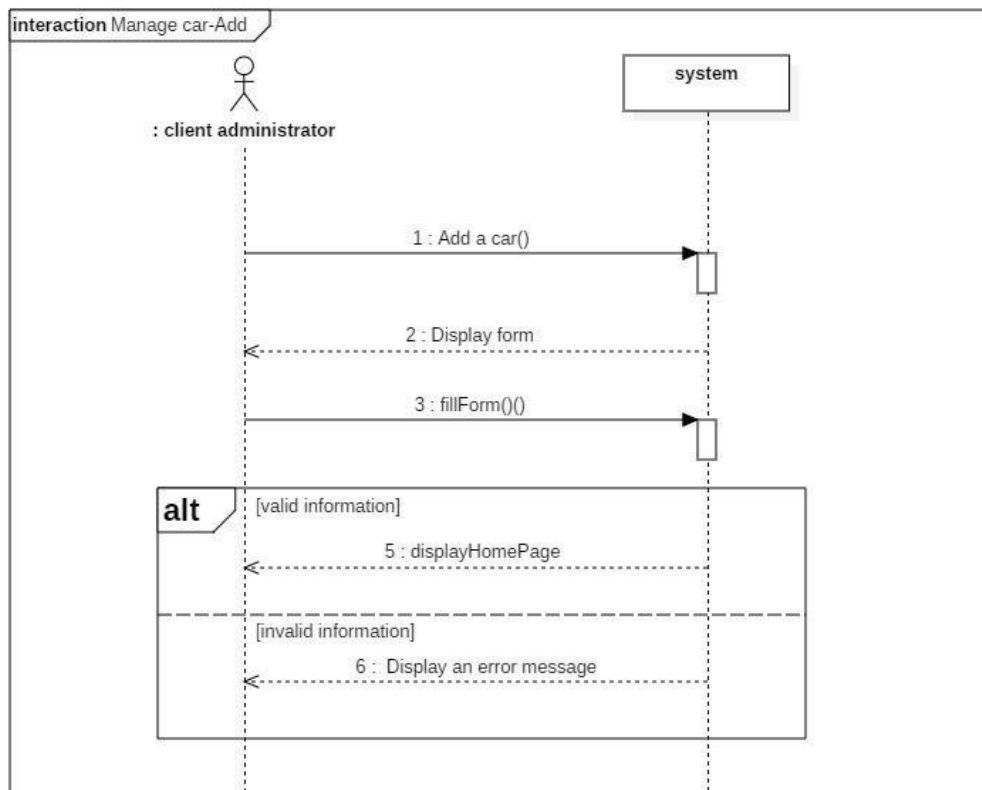

Fig. 3.15 Sequence Diagram Manage car-Add

Sequence Diagram Manage car-edit

This sequence diagram details the steps involved in editing car information by an administrator.

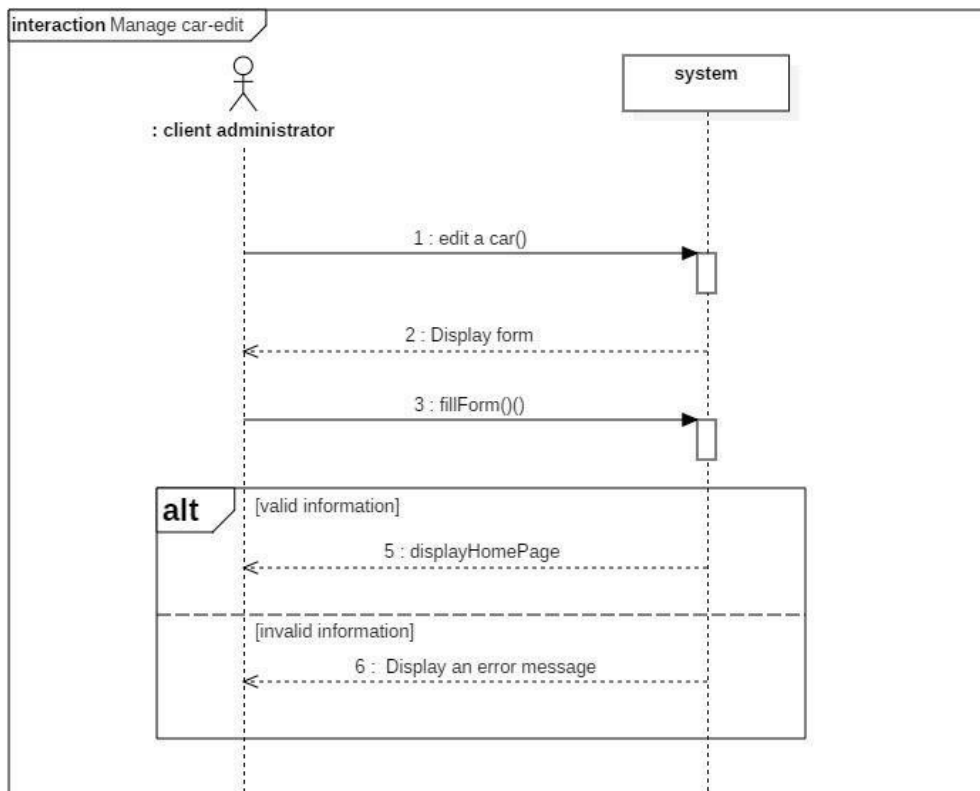

Fig. 3.16 Sequence Diagram Manage car-edit

Sequence Diagram Manage car-delete

This diagram shows the process of deleting a car from the rental system, including interactions with the administrator interface and the car database.

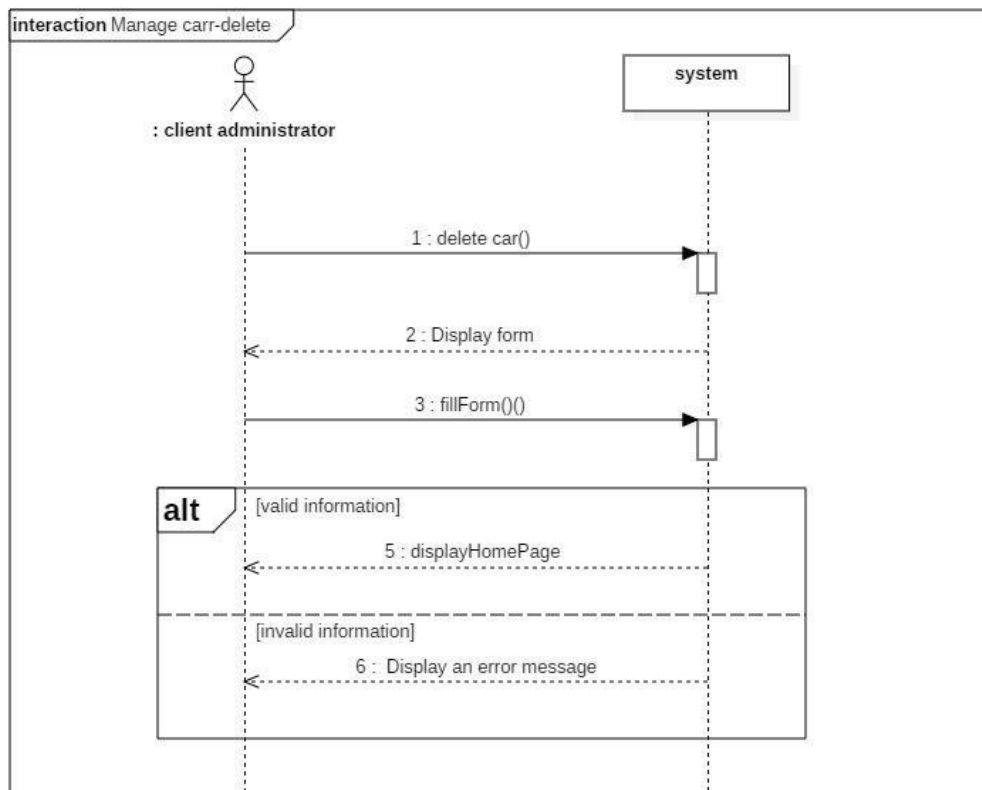

Fig. 3.17 Sequence Diagram Manage car-delete

Sequence Diagram Manage Tourism agency-add

This diagram outlines the process for adding a new tourism agency to the system by an administrator.

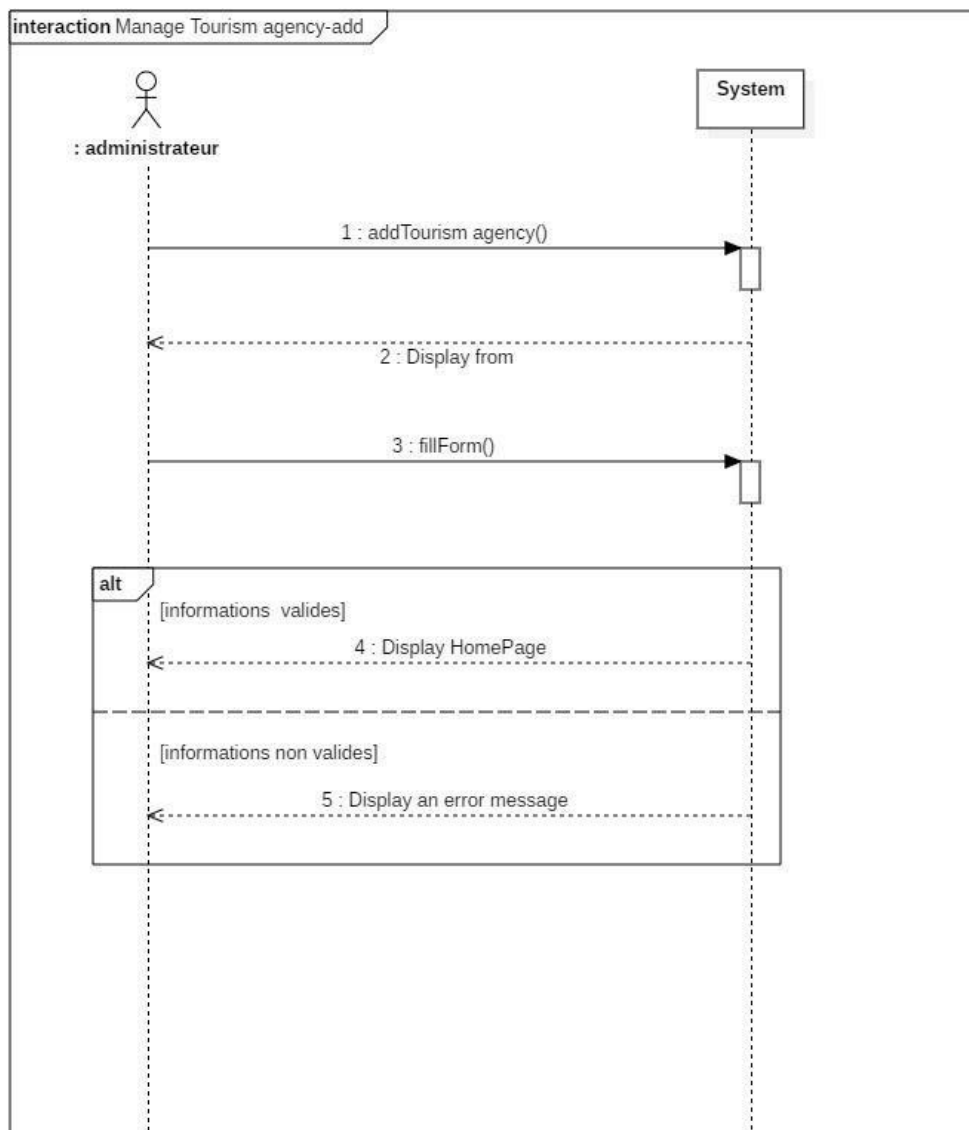

Fig. 3.18 Sequence Diagram Manage Tourism agency-add

Sequence Diagram Manage Tourism Agency-Withdraw

This sequence diagram depicts the process of removing a tourism agency from the system.

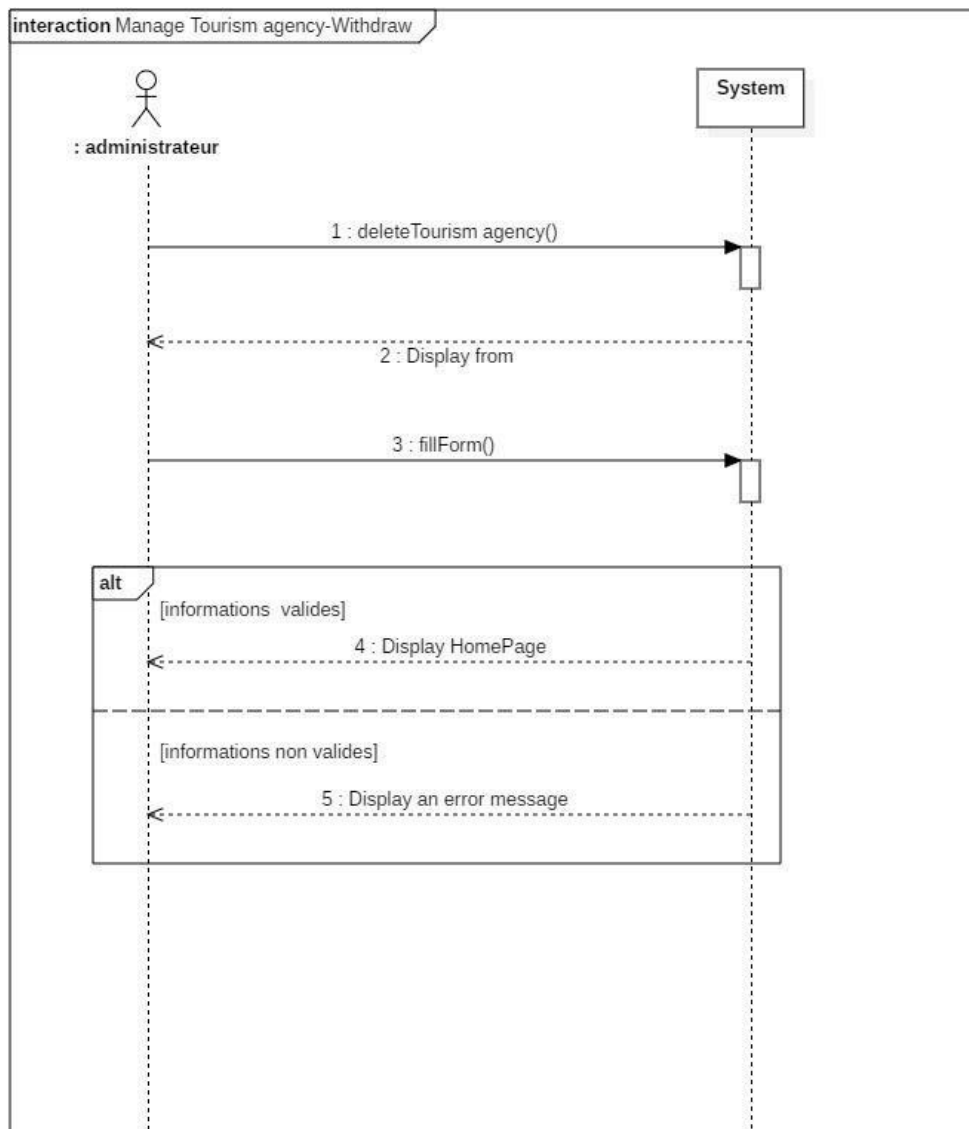

Fig. 3.19 Sequence Diagram Manage Tourism Agency-Withdraw

Sequence Diagram Manage Trip planner-add

This diagram illustrates the steps involved in adding a new trip planner to the system.

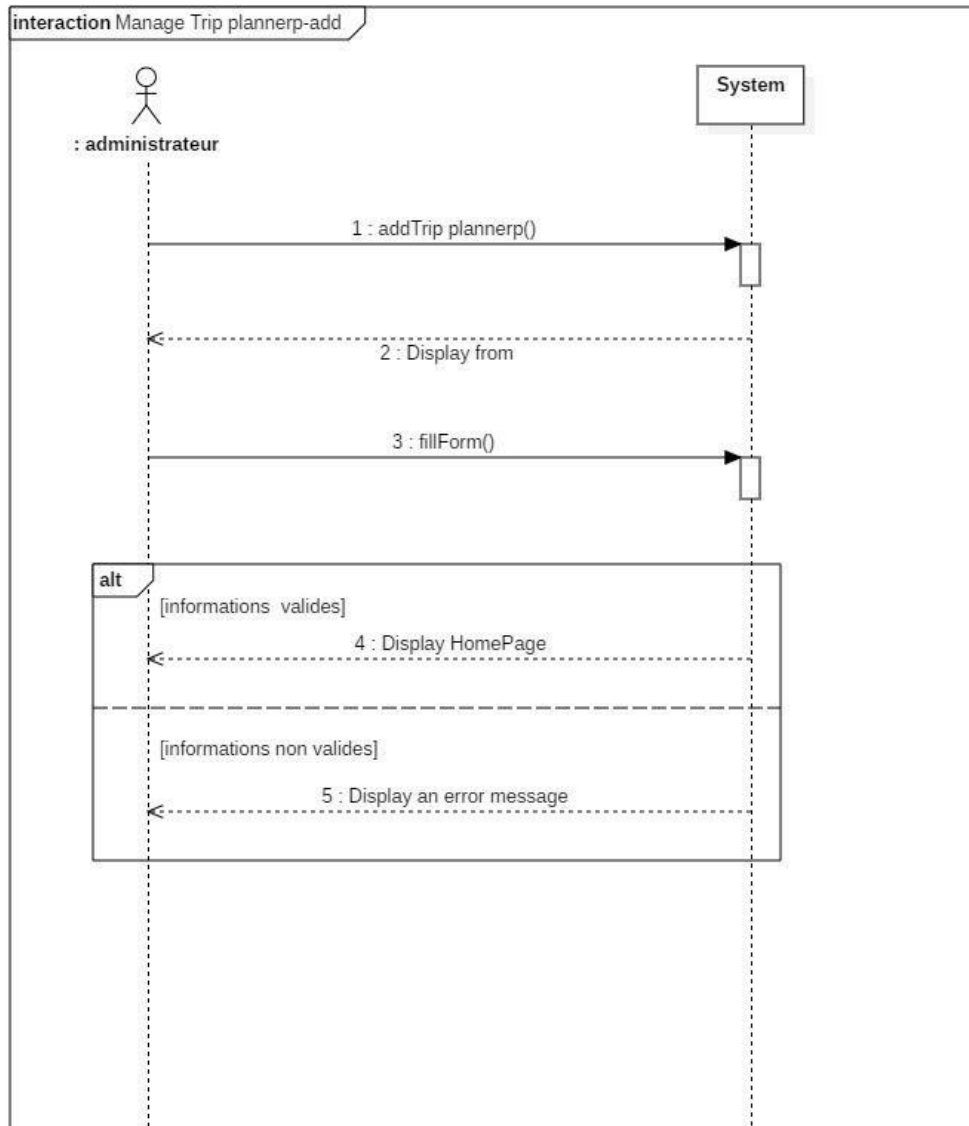

Fig. 3.20 Sequence Diagram Manage Trip planner-add

Sequence Diagram Manage Trip planner-edit

This sequence diagram details the process of editing an existing trip planner's information.

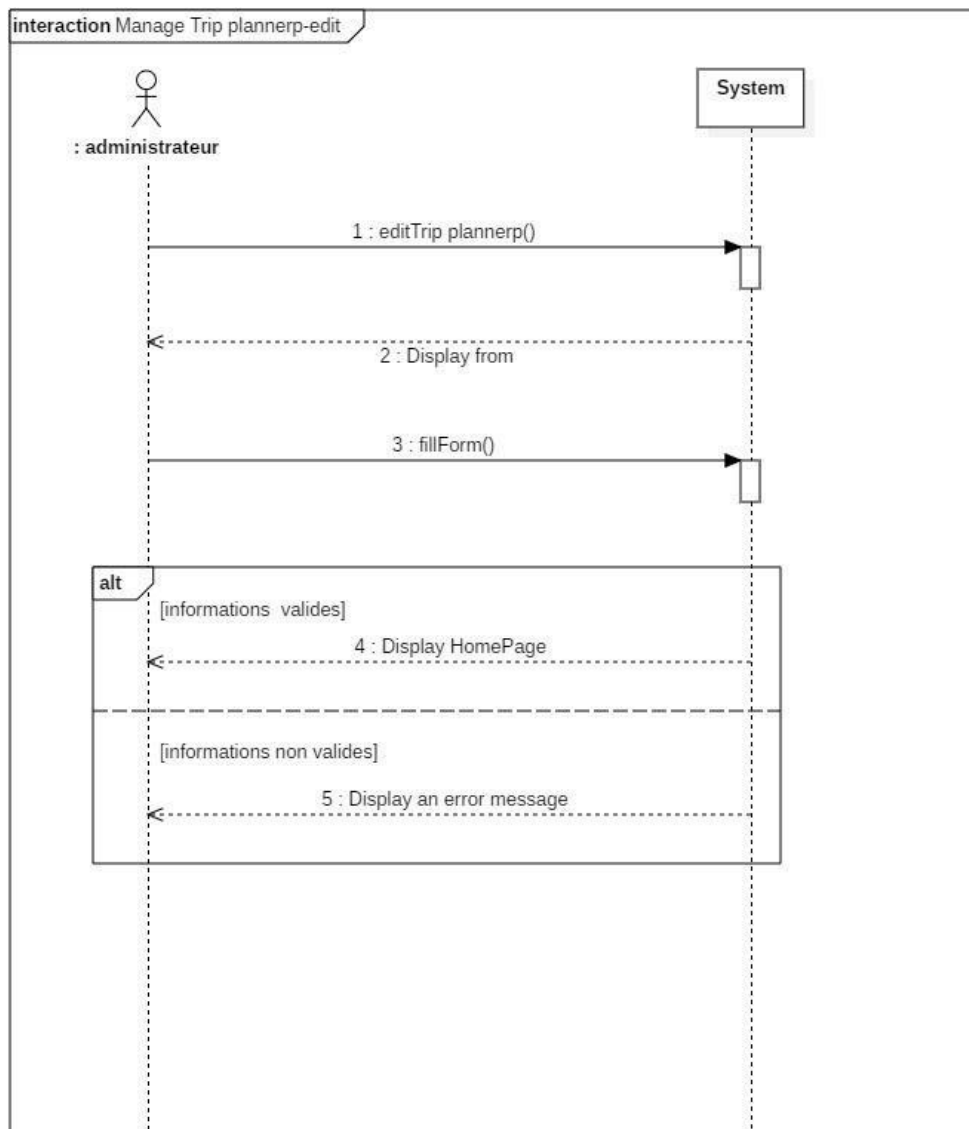

Fig. 3.21 Sequence Diagram Manage Trip planner-edit

Sequence Diagram Manage Trip planner-delete

This diagram shows the process of deleting a trip planner from the system.

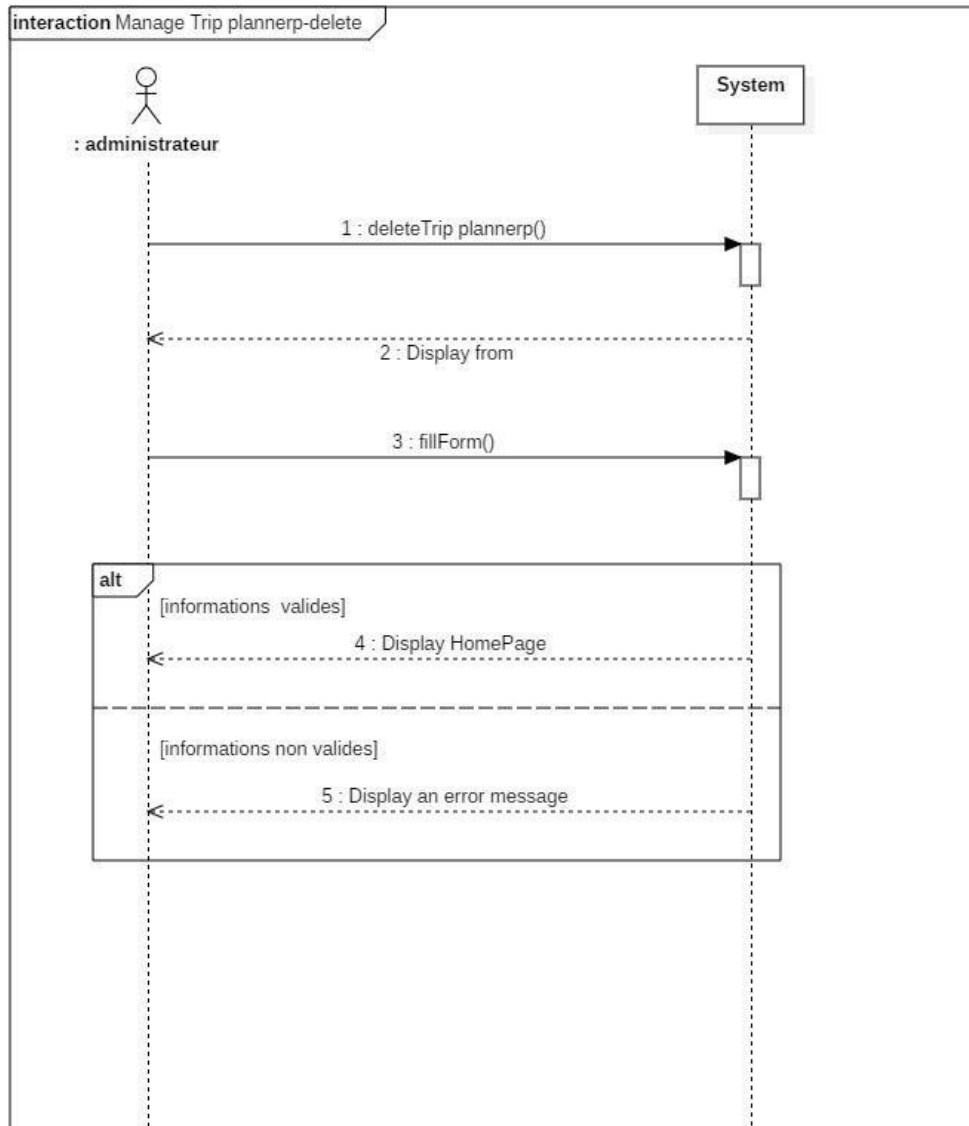

Fig. 3.22 Sequence Diagram Manage Trip planner-delete

Sequence Diagram Manage Guide-add

This diagram depicts the steps taken to add a new tour guide to the system

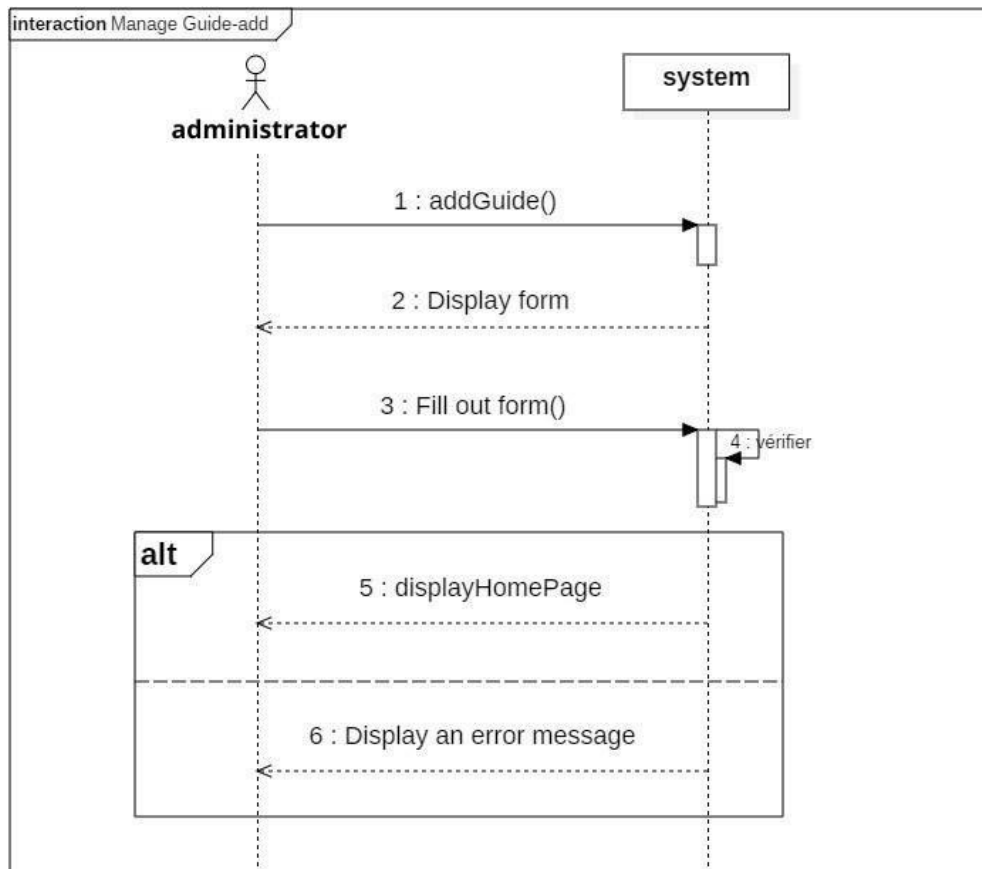

Fig. 3.23 Sequence Diagram Manage Guide-add

Sequence Diagram Manage Guide-edit

This sequence diagram details the process of editing information about a tour guide.

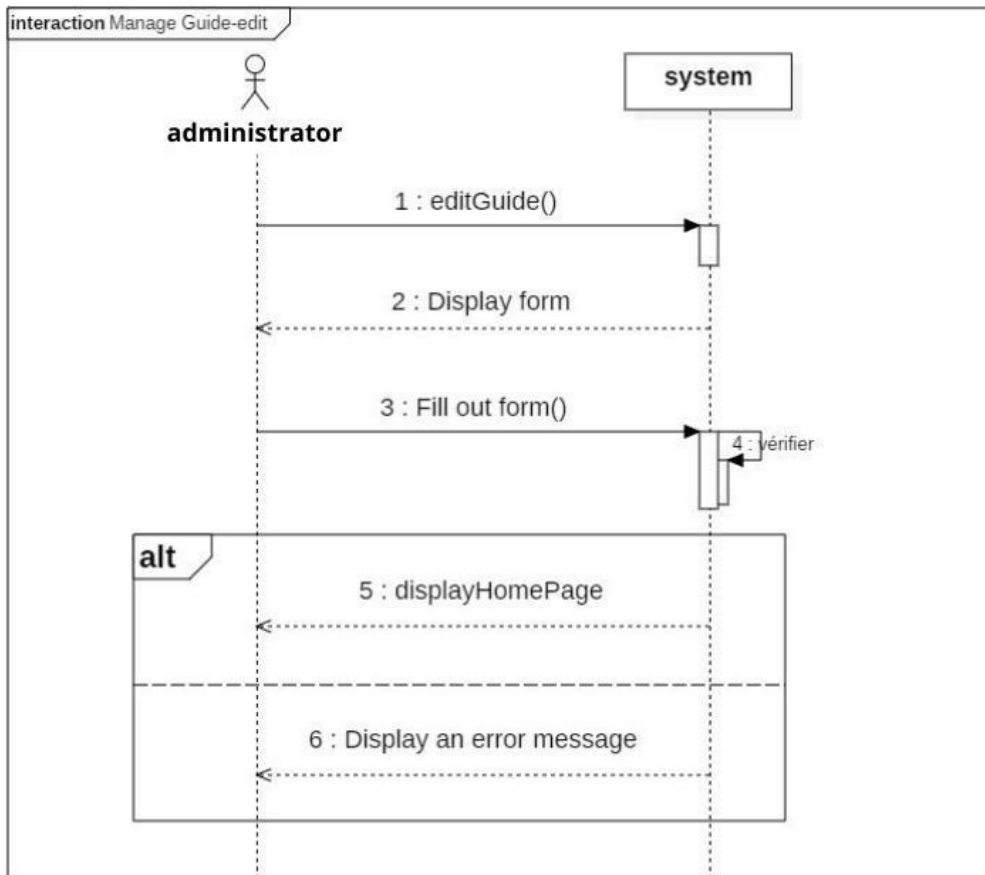

Fig. 3.24 Sequence Diagram Manage Guide-edit

Sequence Diagram Manage Guide-delete

This diagram illustrates the steps involved in deleting a tour guide from the system.

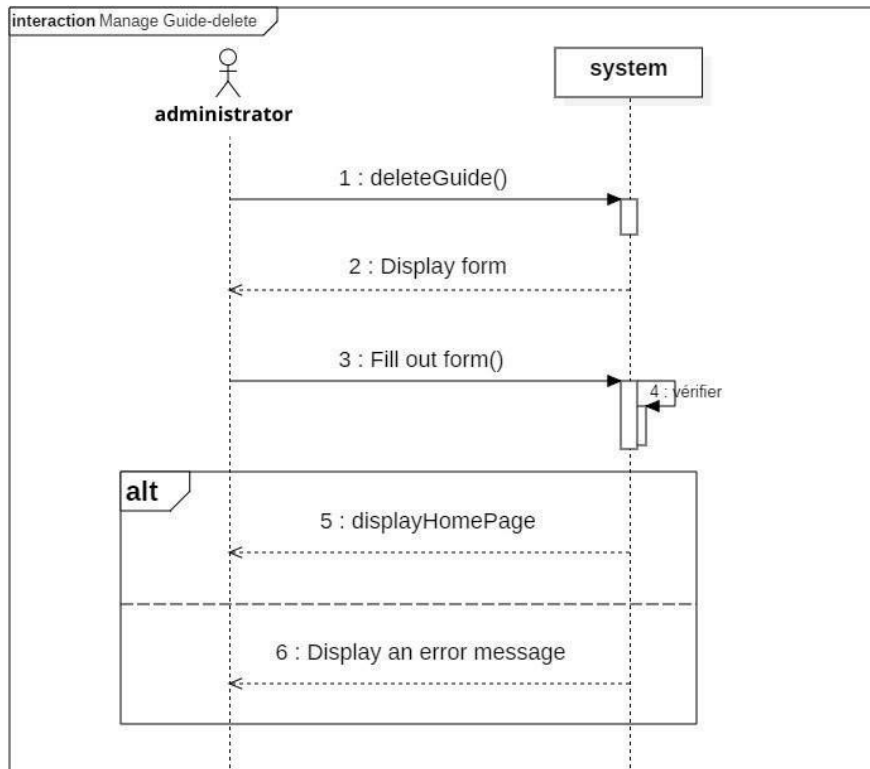

Fig. 3.25 Sequence Diagram Manage Guide-delete

3.5 Class Diagram

The provided diagram is a Class Diagram for a travel and tourism management system. It illustrates the structure of the system by depicting various classes such as Administrator, Tourism Agency, City, Guide, Hotel, Car, Trip Planner, Plane Ticket, Trip Reservations, and Client. Each class includes specific attributes relevant to its role, such as hotel services, car types, and trip details. The Administrator class manages other classes, while the Client class allows clients to make reservations for guides, hotel rooms, cars, plane tickets, and trips. This diagram shows how the system's components interact to efficiently manage and fulfill travel needs.

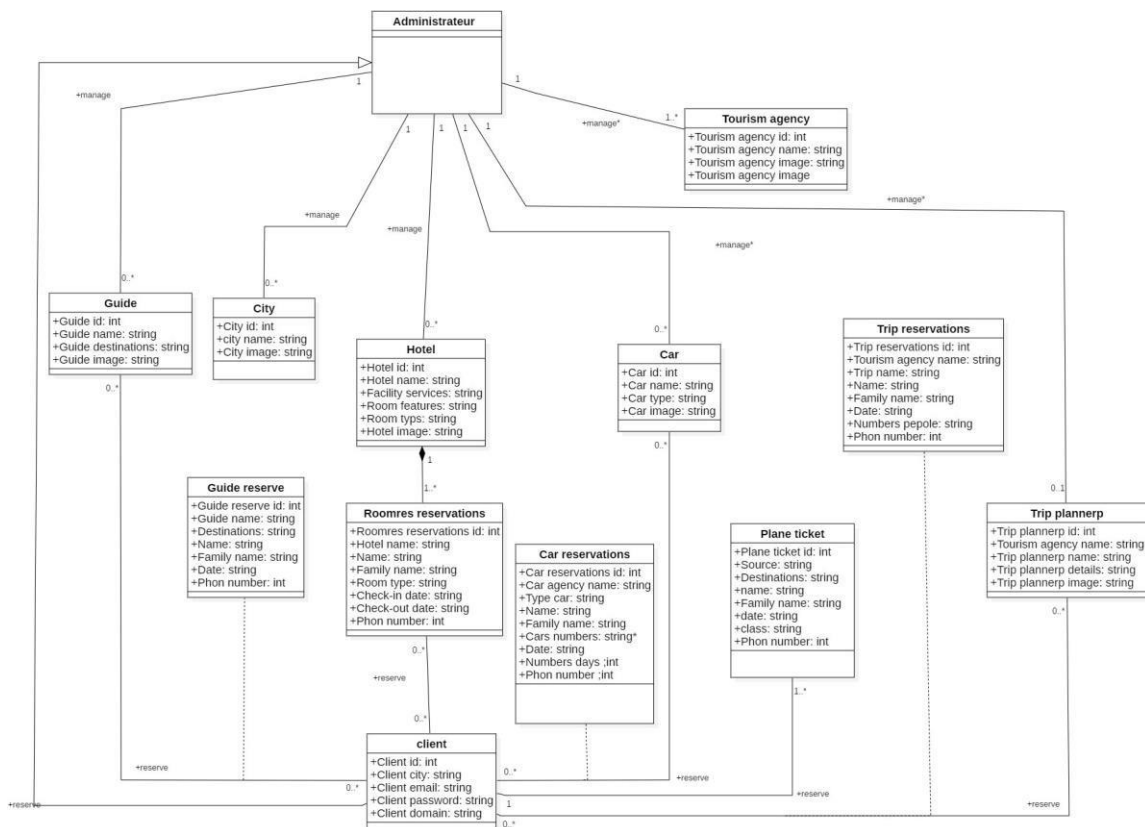

Fig. 3.26 Class Diagram

3.6 Conclusion

In this chapter, we meticulously showcase graphical representations depicting the intricate web of interactions between users and the application. These comprehensive charts, meticulously designed using the STAR UML software, offer a profound insight into the dynamic relationship between users and the application interface.

Chapter 4

Implementation and dissemination of the application.

4.1 Introduction

The realization of a mobile application needs several tools and languages. For this, we have chosen some tools and languages among the existing languages. In this chapter, we will cite the list of tools as well as those of web programming languages that must be gathered for the implementation and interfaces of our application.

4.2 Hardware

We build this app (tour guide) on two laptops whose characteristics and two different mobile phone devices using the Emulator we mention:

Two laptops that do not carry the same first features as 11th Gen Intel (R) Core (TM) i3-1115G4 @ 3.00GHz 3.00 GHz ram 8.00 GB (7.75 GB usable)

Second AMD Ryzen 5 3200G Wraith Stealth Processor (3.6 GHz/4 GHz) ram 8.00 GB (7.75 GB usable)

Mobile phone HUAWEI P 30 Lite Android version 12.0.0.

Redmi Note 9 mobile phone Android version 12.0.0.

With the simple addition that both the first and second devices operate on the operating system (Windows 11(64 Bit)).

4.3 LATEX

LATEX stands out as a complimentary tool employed for the organization and composition of research papers and scholarly communications. It holds its place among the suite of programs available on Linux and Unix operating systems. Offering robust support for rendering mathematical equations with precision, LATEX enables researchers to depict them graphically following their specific requirements and the standards of scientific rigor.[24]

4.4 StarUML

StarUML is an open-source UML (Unified Modeling Language) modeling software that can replace in many situations commercial and expensive software like Rational Rose1 or Together2. Being easy to use, requiring few system resources, and supporting UML 2, this software is an excellent option for modeling familiarization. However, only a Windows version is available.

4.5 Flutter

In the world of software development, "Flutter" is a user interface (user interface) toolkit developed by Google to create locally assembled applications for mobile, web, and desktop platforms from a single software instruction base. It allows developers to create beautiful and high-performance apps using the Dart programming language. [9] Flutter's main features include:

1. Quick Development: Flutter provides a quick reload feature that allows developers to see the changes they made to the code almost immediately without restarting the app, thereby accelerating the development process.
2. Expressive User Interface: Flutter provides a rich range of customizable tools and layouts that enable developers to create visually attractive and responsive user interfaces.
3. High performance: Flutter applications are directly grouped into the original device code, resulting in high performance and smooth animation.

In general, Flutter is a popular framework used in app development. It is very popular with new developers thanks to its ease of use and its ability to create high-quality applications for multiple systems, such as smartphones and tablets. [22]

4.6 Dart

Dart is a powerful and versatile programming language developed by Google. It was first released in 2011 and is designed to be easily used to build web, mobile, and server applications. [25]

Dart provides an efficient and flexible development experience with detailed features (ahead of time) that help improve the speed and performance of your applications.

Dart features include incentive and call management, as well as a powerful memory management system and improved application performance.

Dart is commonly used in the Flutter framework, which is used to build beautiful, seamless user interfaces across multiple platforms, making it ideal for software developers who want to create advanced and attractive applications.

Thanks to an active community and support from Google, Dart is becoming increasingly popular among software developers and is a strong choice for developing innovative applications. [7]

1. As an easy-to-learn and use programming language, Dart features a clear and intuitive structure in its code that facilitates the process of mastering and applying it by developers.
2. Performance is one of the major benefits of using Dart in developing an application. Specifically, the language employs a 'finer-grained' technology that helps accelerate speed and enhance overall efficiency.
3. Dart, in association with Flutter, supports multi-platform application development, meaning that developers can create applications that will run on iOS, Android, and the web using a single codebase.
4. Dart's strong memory management system and the enhanced performance of an application are among the features it provides along with effective catalyst and call management mechanisms.
5. As an excellent medium for physical programming, Dart provides complete support to developers in forming sophisticated data structures and working with inheritance, polymorphism, abstract, and other key computer programming concepts.
6. Active community and strong support: Dart has an active community of developers and shareholders, who provide ongoing support and develop libraries and tools to facilitate the development process.

4.7 Visual Studio

It is a software that Microsoft has specifically designed to edit software codes for all programming languages whether they belong to Microsoft or others. It is a code editor and open source free, fast-forming, and beautiful looking. [20]

He has gained tremendous fame in recent times because of his ability to include desks and packages of mobile-oriented programming languages such as Flutter. Thus, it was able to display different mobile simulators without the need to use android studio which was a huge burden on different devices in its size and energy consumption. Its advantages:

1. Free Program
2. Choose the form you like to develop or design
3. Contains a lot of colors.
4. Organize code well and tightly
5. Contains a thousand libraries to help you complete your project easily
6. Contains keyboard shortcuts

7. It has a terminal to write commands you can take freely without having to install another one When you're a junior or expert software developer, Visual Studio Code stands out as one of the most powerful app development tools. There are a variety of functions and additions that help improve developer productivity while ensuring code quality.

4.8 Android Studio

Android Studio is the official integrated development environment (IDE) for Android application development. It is based on IntelliJ IDEA, a Java-integrated development environment for software, and incorporates its code editing and developer tools. [3][23]

To support application development within the Android operating system, Android Studio uses a Gradle-based build system, Android Emulator, code templates and GitHub integration. Every project in Android Studio has one or more modalities with source code and resource files. These modalities include Android app modules, Library modules and Google App Engine modules.

Android Studio uses an Apply Changes feature to push code and resource changes to a running application. A code editor assists the developer with writing code and offering code completion, refraction and analysis. Applications built in Android Studio are then compiled into the APK format for submission to the Google Play Store.

The software was first announced at Google I/O in May 2013, and the first stable build was released in December 2014. Android Studio is available for macOS, Windows and Linux

desktop platforms. It replaced Eclipse Android Development Tools (ADT) as the primary IDE for Android application development. Android Studio and the Software Development Kit can be downloaded directly from Google. []

4.9 PHP

PHP (Hypertext PreProcessor) is a programming language. Its main application is at the level of management of dynamic websites. One can for example have it create the content of HTML pages (HyperText Markup Language), according to different parameters: the age of a visitor, his socio-professional category, keywords he will have indicated in a search engine, news of the day, etc. The capabilities of PHP do not web pages. It is also possible to manipulate images, images, and create PDF files, and connect to databases. [15]

4.10 XAMPP

XAMPP(X (cross) Apache MariaDB Perl PHP) is a set of software to easily set up a web server and a File Transfer Protocol (FTP) server. This is a distribution of free software with good flexibility of use, known for it's a simple and fast installation. Thus, it is within reach of a large number of people since it does not require any special knowledge and also works on systems most widespread exploitation. [21]

4.11 Hostinger

Hostinger is on a mission to make online success possible for anyone – from developers to aspiring bloggers and business owners. With our fast-hosting technology, AI-powered Website Builder, and easy-to-operate hPanel, growing your website is nothing short of effortless.

Launched in 2004 as a Lithuania-based tech startup, Hostinger is now a leading provider of web hosting solutions, serving over a million like-minded creators from 150+ countries. Staying true to our reputation as the fastest-growing hosting brand of 2020*, we'll continue to improve our services, unlock new markets, and be a part of even more success stories. [11]

-Seamless management tools:

Regardless of your background or technical expertise, our site-building and management tools have been created with user experience and power in mind. Control everything in one place with hPanel, from domains and web hosting to email accounts and more. Have more

time for what matters with our AI-powered drag-and-drop Hostinger Website Builder – create and publish a website within minutes, without limits.

-Website speed:

We want website creators and business owners to move forward, and fast. Imagine having your site load in milliseconds anywhere in the world with our globally distributed servers and 99.9 uptime guarantee. Give your audience the best user experience, and watch as your site rankings improve.

-Dedicated 24/7 support:

for every committed online hustler who aims to rock the web. Our Customer Success team speaks 10+ languages, so you can confidently communicate your thoughts and concerns in your language. Spend less time worrying about technical issues – we promise to get back to you quickly with helpful solutions.

4.12 Implemented Technologies



(a) *LATEX*



(b) *StarUML*



(c) *Flutter*



(d) *Dart*

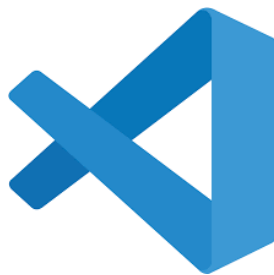

(e) *Visual Studio*



(f) *Android Studio*



(g) *PHP*



(h) *XAMPP*



(i) *Hostinger*

4.13 The application interfaces

Below we offer a range of different interfaces for our app:

Sign up

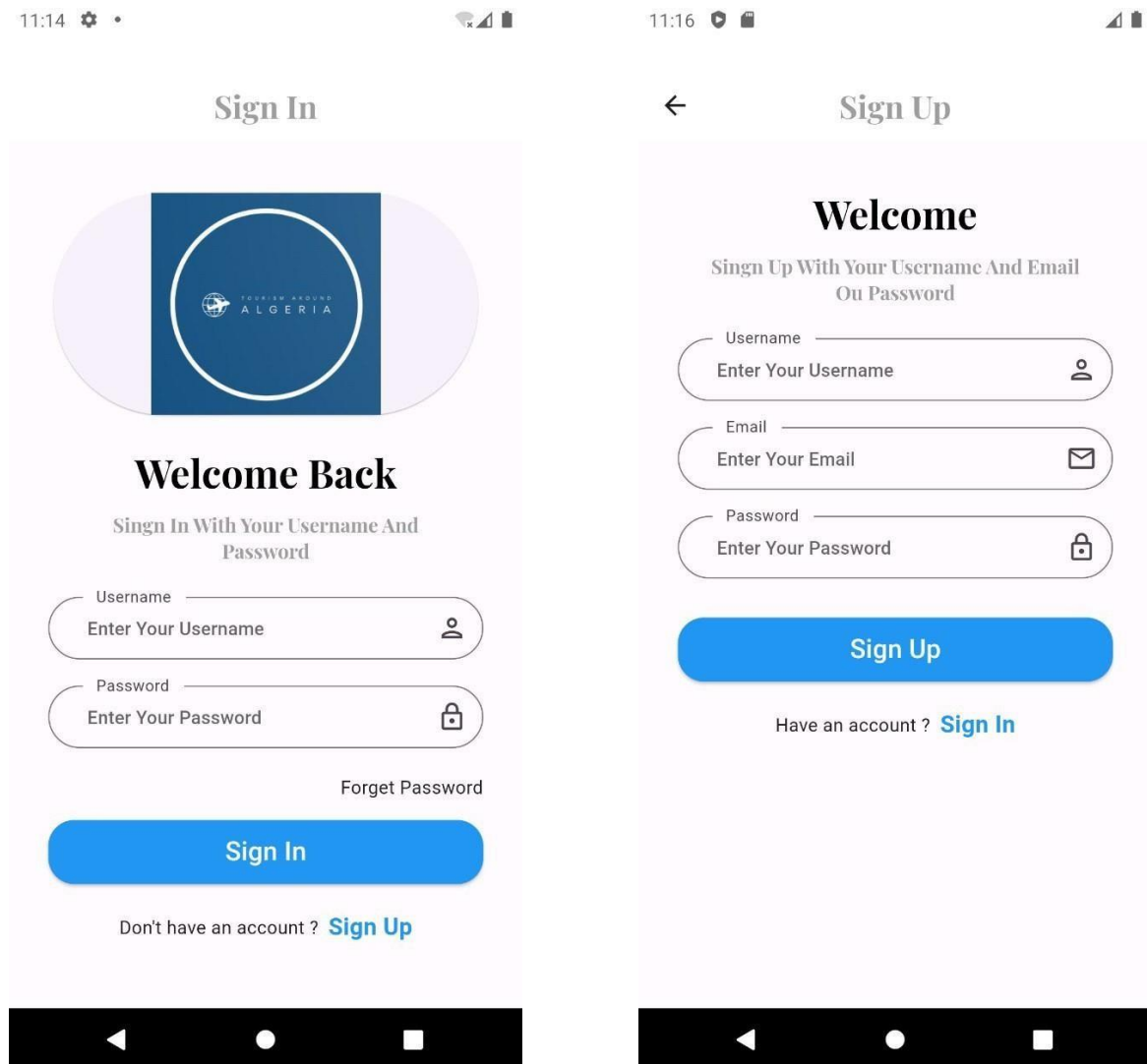

Fig. 4.2 Sign up

Authenticate

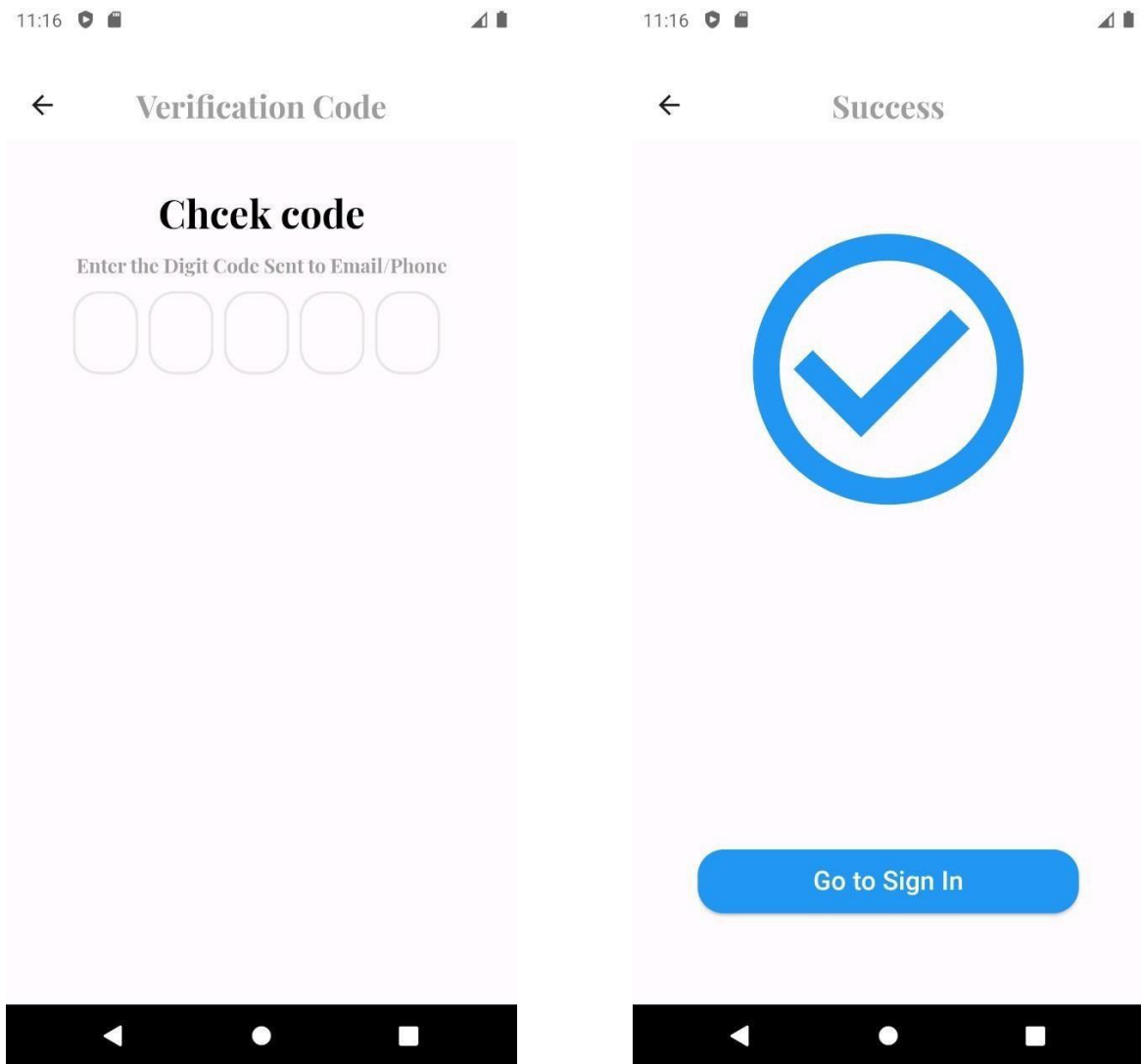

Fig. 4.3 Cheek code

Change of language

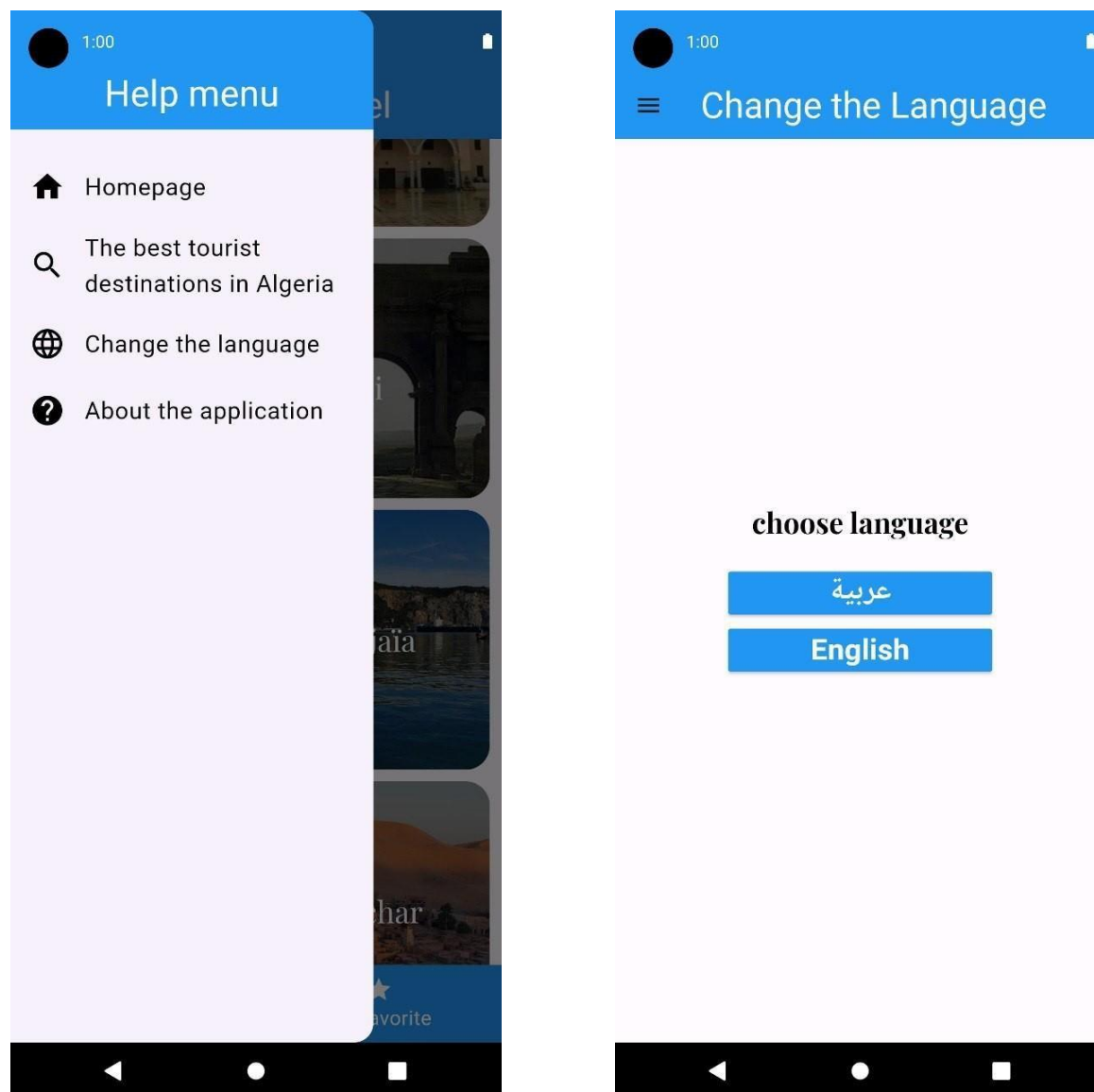

Fig. 4.4 Change of language

Search for States

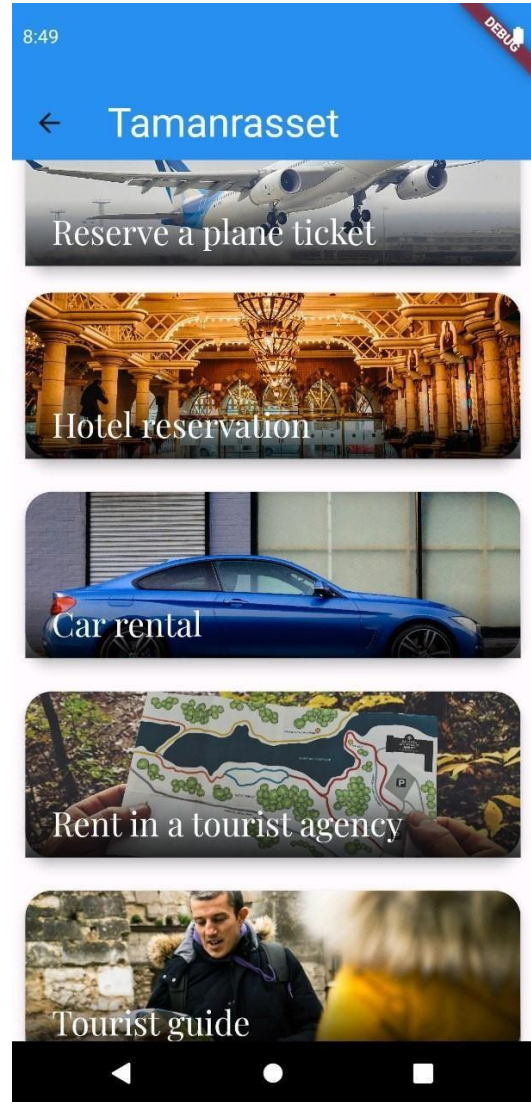

Fig. 4.5 State

Tourist areas

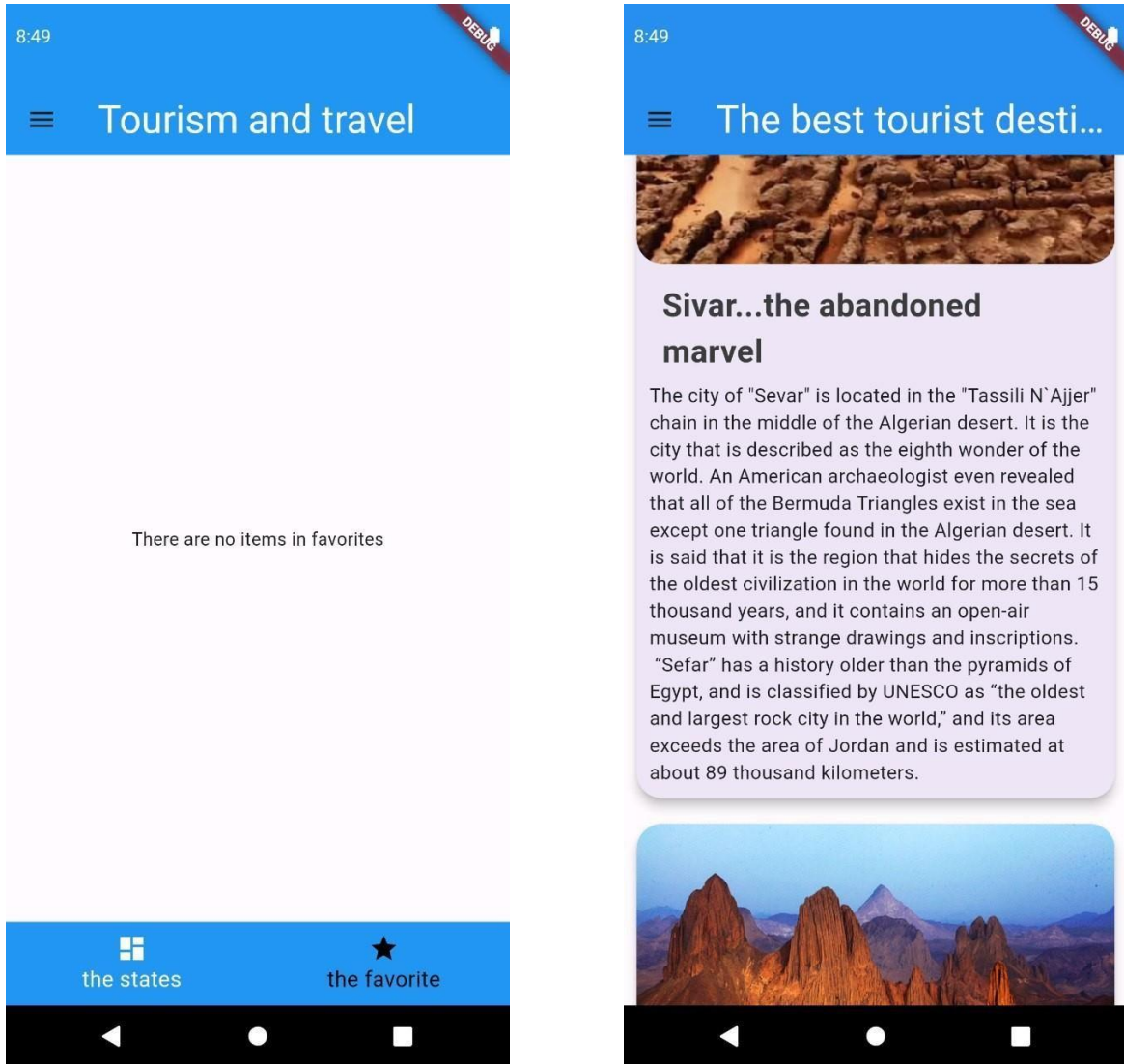

Fig. 4.6 Overview of tourist places in the states of Algeria

Book a plane ticket

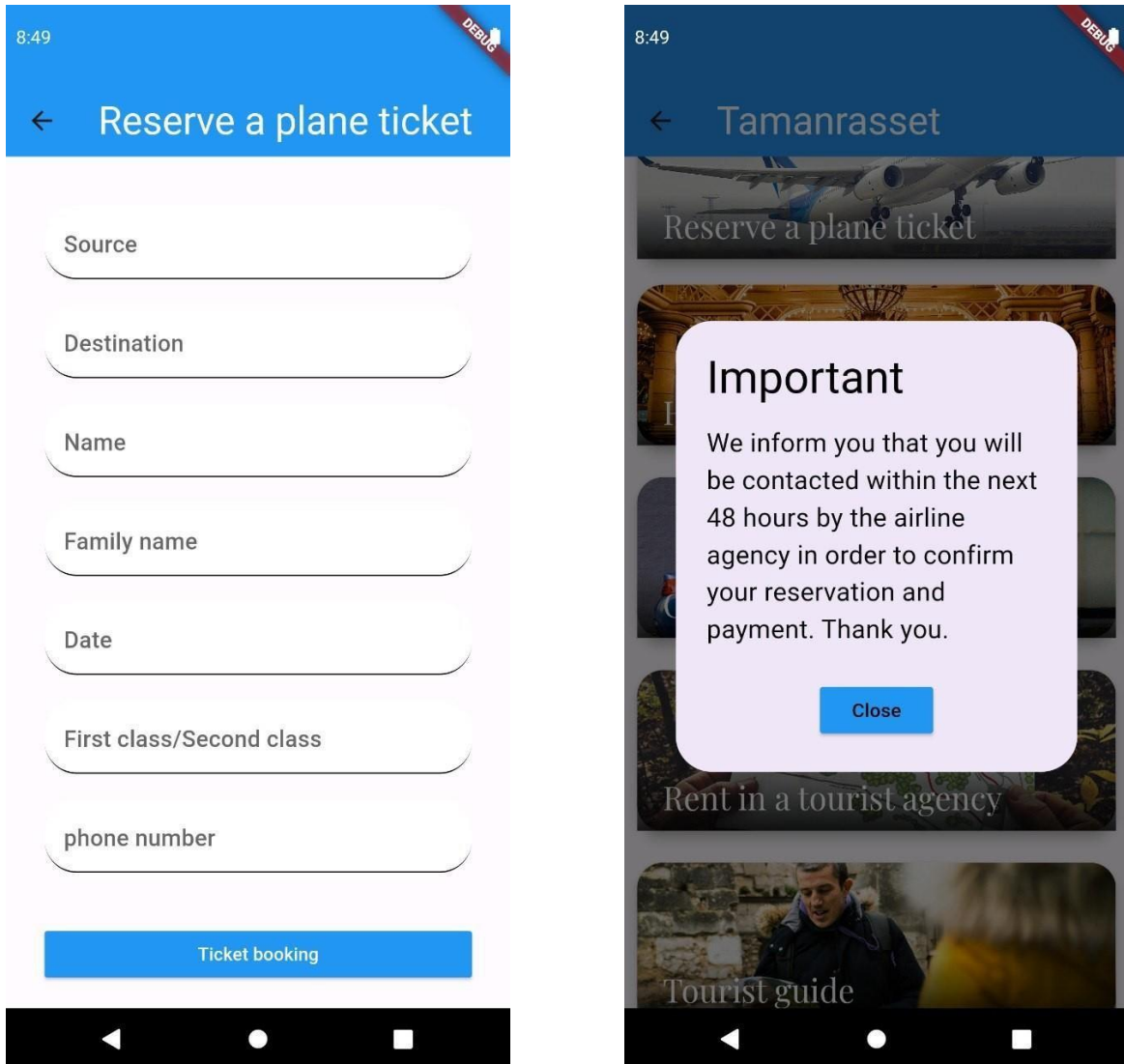

Fig. 4.7 Book a ticket

Hotel reservation

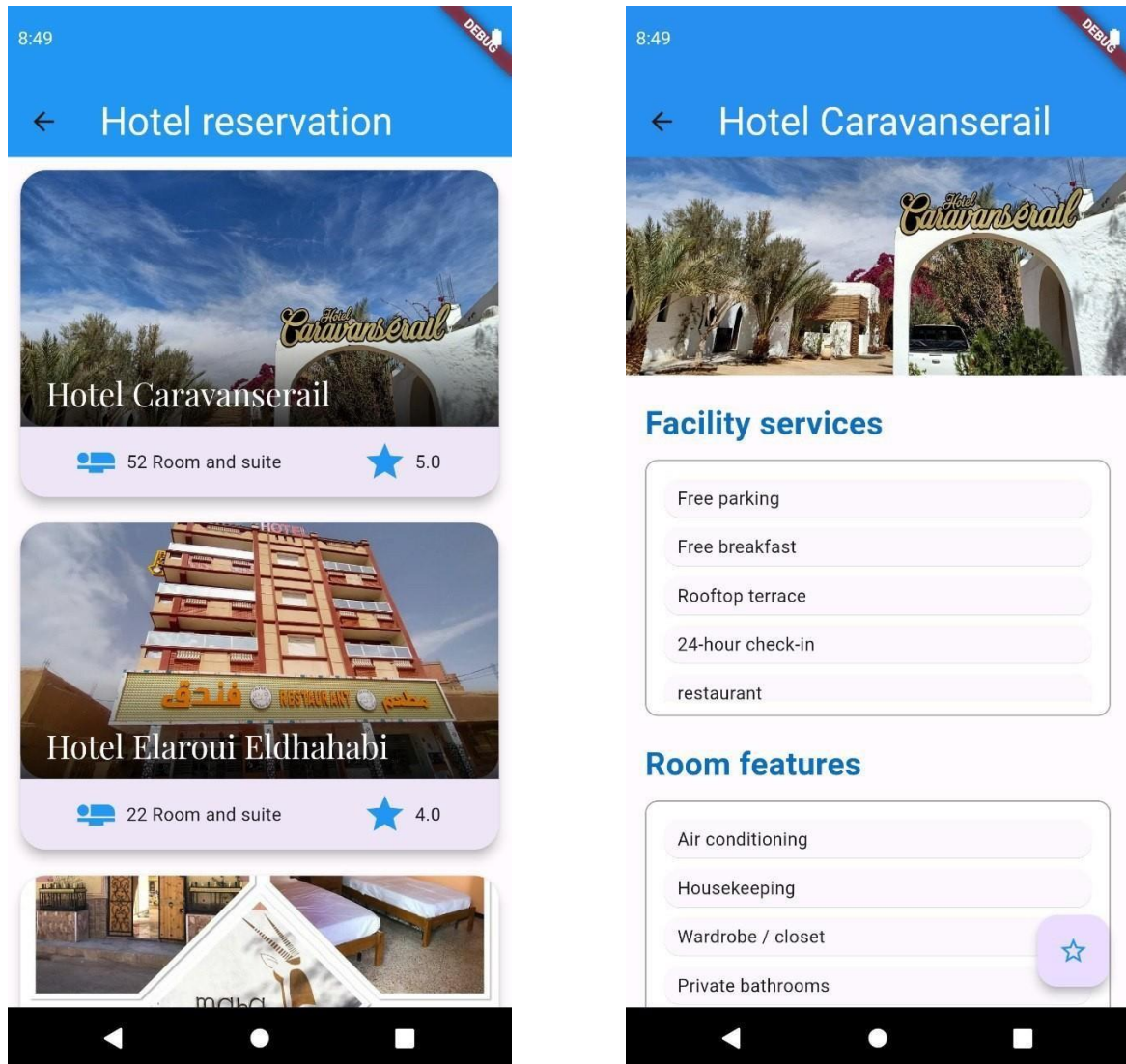

Fig. 4.8 Hotel reservation

Rent a car

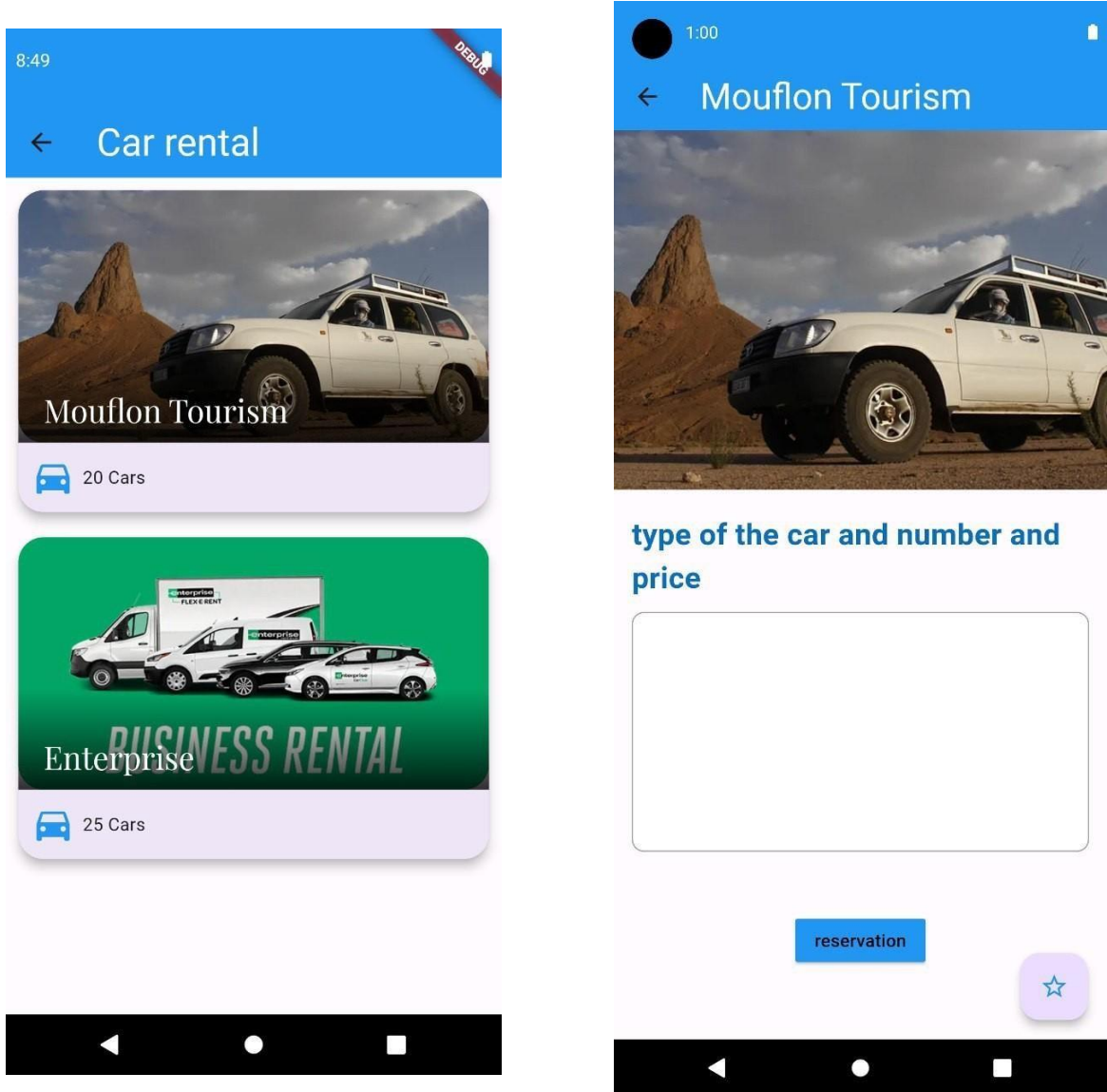

Fig. 4.9 to rent a car

Rent in a tourist agency

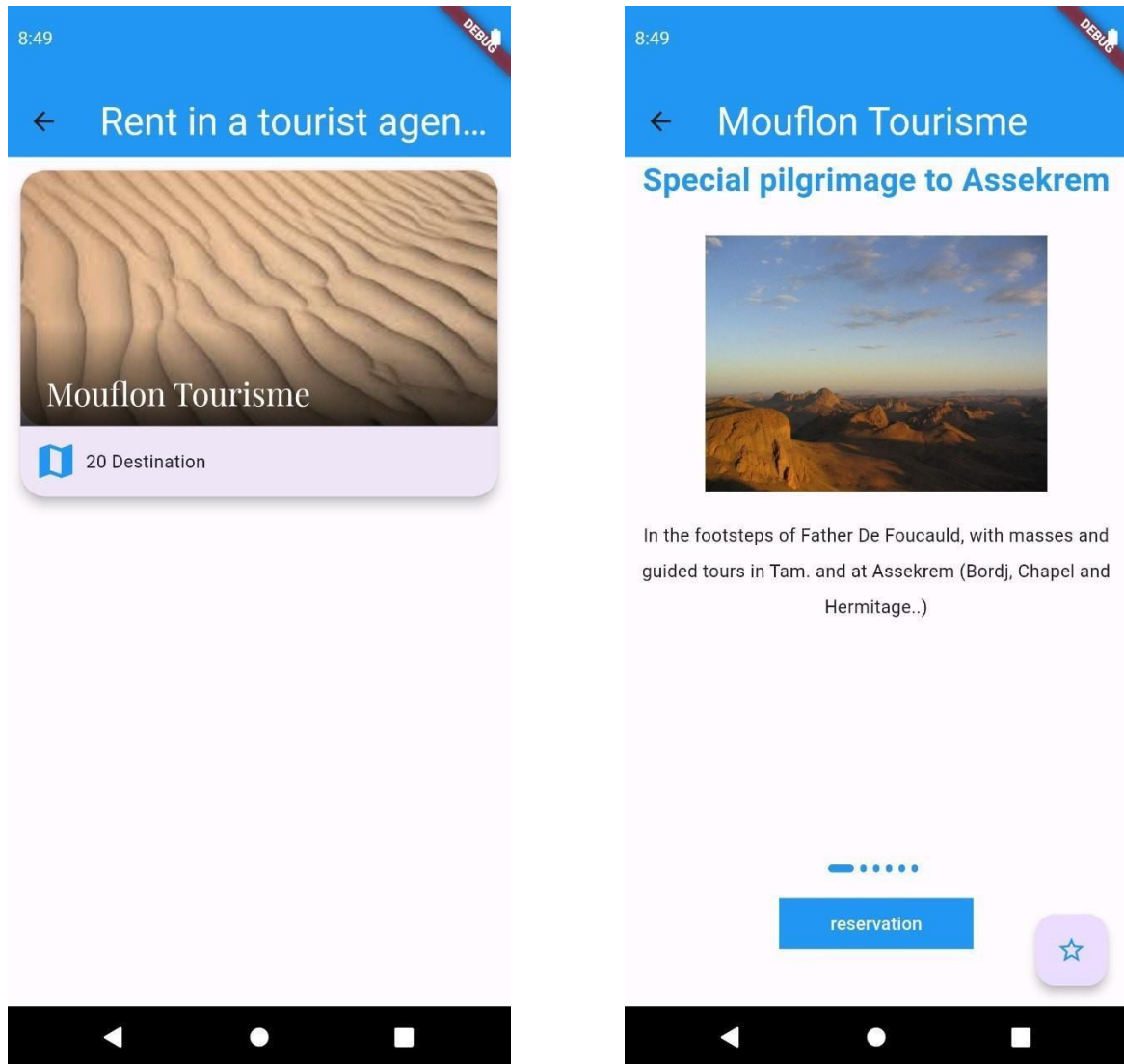

Fig. 4.10 Rent in a tourist agency

Administrator

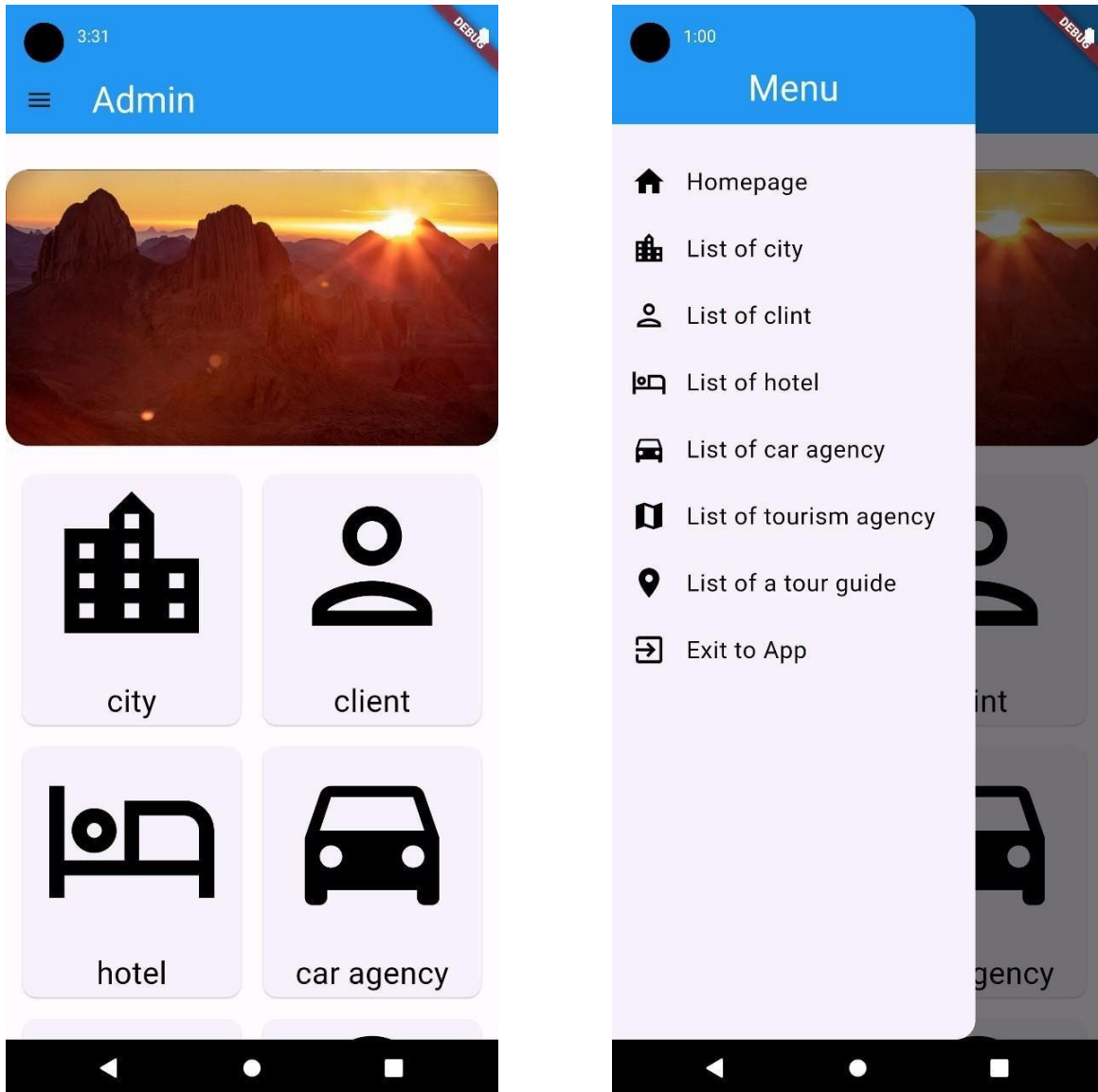

Fig. 4.11 Administrator

Manage city-Add-Edit-Delete

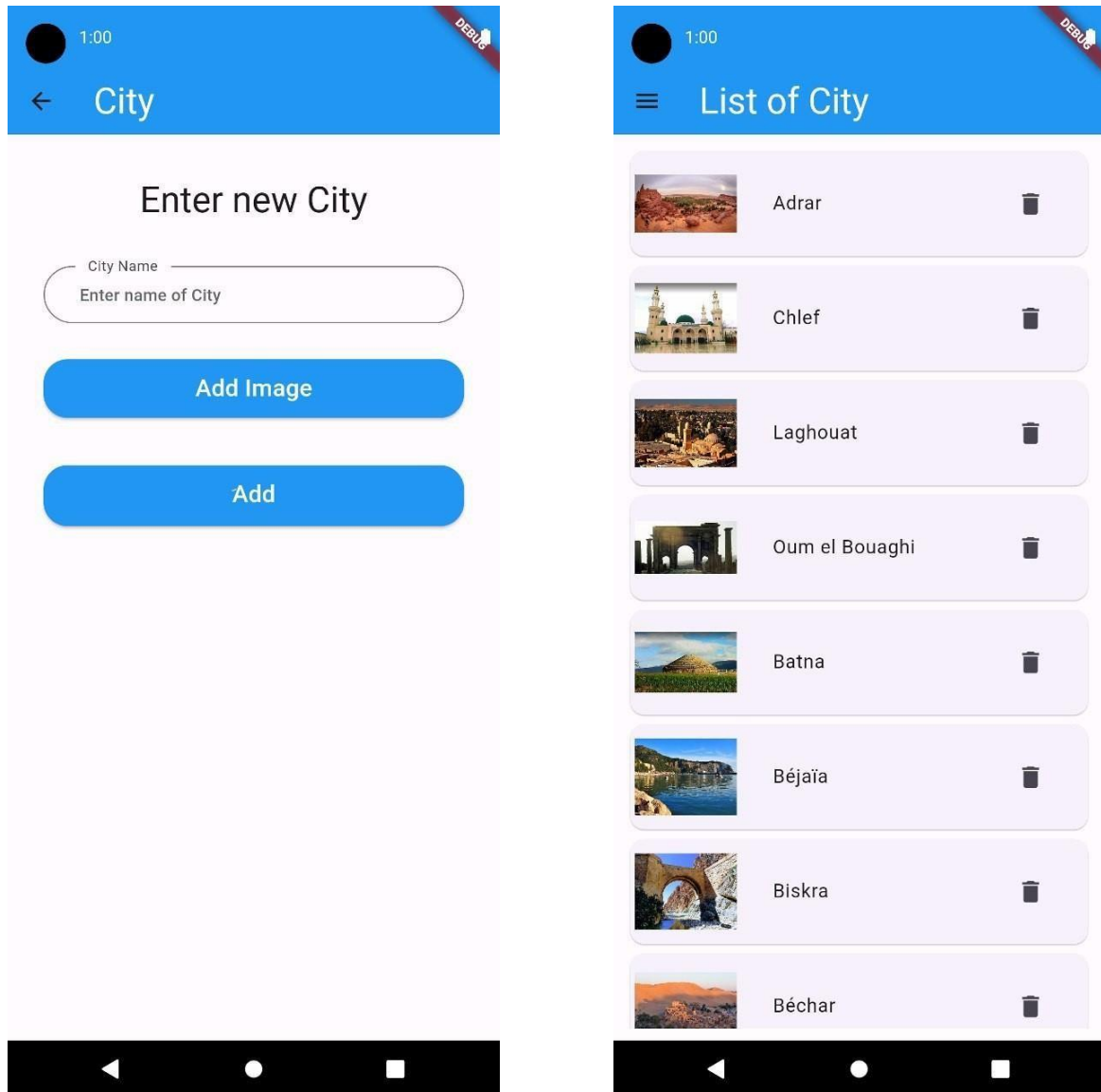

Fig. 4.12 Manage city-Add-Edit-Delete

4.14 Conclusion

In this chapter, we have introduced the tools and software utilized in developing our application. Additionally, we have presented various app interfaces. The implementation phase has enabled us to realize the outcomes of the preceding stages and has facilitated our acquisition of the requisite languages and tools for mobile application development.

General Conclusion

In this endeavor, we undertook the design and development of a mobile application for a travel and tourism agency in Algeria. The aim of this application is to streamline the process of booking flights, hotels, and cars, while also providing informative guidance for tourists. Additionally, it offers customer support services and deals. This project responds to the growing market demand for reliable mobile applications that swiftly and efficiently meet tourists' needs, while also taking into consideration local characteristics.

Key Achievements:

Our accomplishments span across various dimensions of application development. Leveraging cutting-edge technologies like Flutter and Dart, we meticulously engineered a robust application finely attuned to user exigencies. These technologies endowed us with a sophisticated development milieu, facilitating the creation of high-performance applications compatible across diverse operating systems.

In the realm of user interface design, our focus remained steadfast on fashioning intuitive and streamlined interfaces, harnessing the capabilities of tools such as Android Studio and Visual Studio. Our design ethos revolved around fostering effortless navigation and lucidity, thereby ensuring an unparalleled user experience, ultimately culminating in heightened user satisfaction and enhanced engagement with the application.

Moreover, our analytical and testing endeavors were conducted with utmost precision. We conducted exhaustive analysis of user requirements and subjected the application to rigorous testing protocols to ascertain its seamless and efficient functionality. Our testing regimen encompassed a comprehensive array of functional and non-functional tests, ensuring optimal performance, steadfast stability, and robust security. Additionally, we continuously iterated and refined the application based on invaluable user feedback, ensuring its alignment with evolving user preferences and expectations.

Challenges

The project encountered several challenges, including:

-Content and service limitations in global applications:

We addressed this challenge by providing localized content and customized services tailored specifically for the Algerian market. This included comprehensive information on local tourist attractions, restaurants, and cultural events.

-Data integration:

Integrating data from various sources and ensuring continuous information updates posed a significant challenge. We employed modern integration techniques to ensure data accuracy and seamless updates.

Recommendations

To further enhance the application in the future, we recommend:

-Adding more languages:

Expanding language support, including English and French, will broaden the user base and cater to international tourists.

-Continuous content updates:

Regularly updating content is essential to provide users with the latest information and offers. Partnering with local and international tourism entities can ensure access to up-to-date tourism information and deals.

-Improving user experience:

Listening to user feedback and implementing necessary updates is crucial. Utilizing artificial intelligence techniques to analyze user feedback and suggest automatic improvements can enhance the overall user experience.

-Enhancing data security:

Protecting user data and maintaining privacy is paramount. This involves implementing advanced encryption techniques and enforcing strict security policies.

The project demonstrates that leveraging modern technologies and user-centric design can significantly improve the travel and tourism experience in Algeria. Through this application, we have provided an integrated platform that assists tourists in planning their trips with ease, thereby enhancing Algeria's position as a distinctive tourist destination.

References

- [1] History of travel agency and tour operation, 2024. URL <https://uou.ac.in/sites/default/files/slm/ETS-103.pdf>. Accessed: 2024-04-04.
- [2] Official website of the Ministry of Tourism, 2024. URL <https://alger.mta.gov.dz>. Accessed: 2024-04-21.
- [3] Android studio documentation, 2024. URL <https://developer.android.com/studio>. Accessed: 2024-06-05.
- [4] Bellone. diagrammes des classes participantes, 2024. URL http://agapesmiage.free.fr/Packages%20m%E9tiers/Gestionnaire_de_stocks/Classes%20participantes/rapport_participant.pdf. Accessed: 2024-05-23.
- [5] booking, 2024. URL <https://www.booking.com/content/about.en>. Accessed: 2024-03-27.
- [6] Clubic. pcestar uml diagrammer, 2024. URL <https://www.clubic.com/telecharger-fiche220230-pcestar-uml-diagrammer.html>. Accessed: 2024-03-27.
- [7] dart, 2024. URL <https://dart.dev>. Accessed: 2024-04-05.
- [8] Journal of economics and development for research and studies, 2024. URL <https://www.asjp.cerist.dz/en/PresentationRevue/273>. Accessed: 2024-04-01.
- [9] flutter, 2024. URL <https://flutter.dev>. Accessed: 2024-04-26.
- [10] hopper, 2024. URL <https://hopper.com/>. Accessed: 2024-03-27.
- [11] Hostinger, 2024. URL <https://www.hostinger.ae/>. Accessed: 2024-05-24.
- [12] kayak, 2024. URL <https://www.kayak.com>. Accessed: 2024-04-04.
- [13] Definition of tourism, 2024. URL <https://mawdoo3.com>. Accessed: 2024-03-27.
- [14] Types of tourism, 2024. URL <https://mawdoo3.com>. Accessed: 2024-04-21.
- [15] php, 2024. URL <https://www.php.net>. Accessed: 2024-04-27.
- [16] , 2024. URL <https://www.safarway.com/about-us>. Accessed: 2024-03-27.
- [17] Uml et le processus unifié, 2024. URL <http://dSPACE.univ-tlemcen.dz/bitstream/112/5500/5/chapitre1.pdf>. Accessed: 2024-05-11.

-
- [18] Uml : les diagrammes de séquence, 2024. URL <http://tvaira.free.fr/dev/uml/UML-DiagrammesDeSequence.pdf>. Accessed: 2024-04-28.
 - [19] Unwto | World Tourism Organization a un specialized agency, 2024. Accessed: 2024-04-03.
 - [20] Visual Studio code, 2024. URL <https://framalibre.org/content/visual-studio-code>. Accessed: 2024-05-21.
 - [21] Xampp official website, 2024. URL <https://www.apachefriends.org/index.html>. Accessed: 2024-06-05.
 - [22] Barry Burd. *Flutter for Dummies*. For Dummies, 2020. ISBN 978-1119612582.
 - [23] Jerome DiMarzio. *Beginning Android Programming with Android Studio*. Wrox, 2016. ISBN 978-1118705599.
 - [24] Leslie Lamport. *LaTeX: A Document Preparation System*. Addison-Wesley, 1994. ISBN 978-0201529838.
 - [25] Kathy Walrath and Seth Ladd. *Dart: Up and Running*. O'Reilly Media, 2013. ISBN 978-1449330897.

Abstract

This report presents a project to develop a smartphone app in tourism entitled "Tourism in Algeria", which aims to provide an excellent experience for travelers, enabling them to explore tourist destinations efficiently and easily. The app seeks to bridge the gap in the Algerian market by providing comprehensive and reliable information on major tourist destinations, including attractions, hotels, transportation, cultural and recreational activities, as well as ticket bookings, hotels, and tour plans. In addition, it provides a comprehensive technical document of the system, from commercial analysis and design to implementation and deployment. The app features a simple and attractive user interface that includes search options and tourist ads, making it easier for users to find the required information quickly and easily.

Keywords: Travel and tourism services in Algeria, Tourist places in Algeria, Tourism Pillars, Flutter, Dart, Application design, Application interfaces.

Résumé

Ce mémoire présente un projet de développement d'une application smartphone dans le tourisme intitulé "Tourisme en Algérie", qui vise à fournir une excellente expérience aux voyageurs, leur permettant d'explorer les destinations touristiques efficacement et facilement. L'application cherche à combler le fossé sur le marché algérien en fournissant des informations complètes et fiables sur les principales destinations touristiques, y compris les attractions, les hôtels, les transports, les activités culturelles et récréatives, ainsi que les réservations de billets, les hôtels et les plans de visites. En outre, il fournit un document technique complet du système, de l'analyse commerciale à la conception, en passant par la mise en œuvre et le déploiement. L'application dispose d'une interface utilisateur simple et attrayante qui comprend des options de recherche et des annonces touristiques, ce qui permet aux utilisateurs de trouver plus facilement et rapidement les informations requises.

Keywords: Travel and tourism services in Algeria, Tourist places in Algeria, Tourism Pillars, Flutter, Dart, Application design, Application interfaces.

ملخص

تقدم هذه المذكرة مشروع تطوير تطبيق هاتف ذكي في مجال السياحة بعنوان "السياحة في الجزائر"، الذي يهدف إلى توفير تجربة ممتازة للمسافرين، مما يتيح لهم استكشاف الوجهات السياحية بكفاءة وسهولة. يسعى التطبيق إلى سد الفجوة في السوق الجزائرية من خلال توفير معلومات شاملة وموثوقة حول الوجهات السياحية الرئيسية، بما في ذلك الجذب السياحي، والفنادق، ووسائل النقل، والأنشطة الثقافية والترفيهية، بالإضافة إلى حجوزات التذاكر والفنادق وخطط الزيارات.

توفر المذكرة وثيقة فنية شاملة للنظام، من التحليل التجاري إلى التصميم، وصولاً إلى التنفيذ والنشر. يحتوي التطبيق على واجهة مستخدم بسيطة وجذابة تتضمن خيارات البحث والإعلانات السياحية، مما يتيح للمستخدمين العثور بسهولة وسرعة على المعلومات المطلوبة.

الكلمات المفتاحية: خدمات السفر والسياحة في الجزائر، الأماكن السياحية في الجزائر، ركائز السياحة، الرفرفة، السهام، تصميم التطبيقات، واجهات التطبيق.