



Mohamed Boudiaf University - M'sila
FACULTY OF TECHNOLOGY
DEPARTMENT OF ELECTRICAL ENGINEERING



Serial number.....

Registration number: D.ER/3C/03/22

Thesis

Presented for the Degree of

DOCTORATE LMD

Field: Renewable Energies

Speciality: Renewable Energies

THEME

**Improvement of Performance in Energy Systems
from Renewable Sources Based on Green Hydrogen**

Presented By

Yacine BENCHENINA

Supported on: 22/04/2025

Before the jury composed of:

<u>Name & Surname</u>	<u>Grade</u>	<u>Establishment</u>	<u>Quality</u>
Ismail GHADBANE	Professor	University of M'Sila	President
Abderrahim ZEMMIT	Associate Professor A	University of M'Sila	Supervisor
Mohammed Moustafa BOUZAKI	Associate Professor B	University of Blida 1	Co-Supervisor
Yassine BENSAFIA	Professor	University of Bouira	Examiner
Abdelghafour HERIZI	Associate Professor A	University of M'Sila	Examiner
Riyadh ROUABHI	Associate Professor A	University of M'Sila	Examiner
Khatir KHETTAB	Professor	University of M'Sila	Guest

Academic year: 2024/2025



Université Mohamed Boudiaf - M'Sila

FACULTE DE TECHNOLOGIE

DEPARTEMENT DE GENI ELECTRIQUE



Numéro de série.....

Numéro d'inscription : D.ER/3C/03/22

Thèse

Présentée pour l'obtention du diplôme de

DOCTORAT LMD

Filière: Énergies Renouvelables

Spécialité: Énergies Renouvelables

THEME

**Amélioration des Performances des Systèmes
énergétiques de sources renouvelables à base de
l'hydrogène vert**

Présentée Par

Yacine BENCHENINA

Soutenue le: 22/04/2025

Devant le jury composé de:

<u>Nom & Prénom</u>	<u>Grade</u>	<u>Établissement</u>	<u>Qualité</u>
Ismail GHADBANE	Professeur	Université de M'Sila	Président
Abderrahim ZEMMIT	MCA	Université de M'Sila	Encadreur
Mohammed Moustafa BOUZAKI	MCB	Université de Blida 1	Co-Encadreur
Yassine BENSALIA	Professeur	Université de Bouira	Examineur
Abdelghafour HERIZI	MCA	Université de M'Sila	Examineur
Riyadh ROUABHI	MCA	Université de M'Sila	Examineur
Khatir KHETTAB	Professeur	Université de M'Sila	Invité

Année Universitaire : 2024/2025

Declaration

I hereby declare that the work presented in this thesis has not been submitted for any other degree or professional qualification, and that it is the result of my own independent work.

BENCHENINA Yacine

Date

Publications associated with this research

PUBLICATIONS

- **Yacine Benchenina**, Abderrahim Zemmit, Mohammed Moustafa Bouzaki et al. Advancing green hydrogen production in Algeria with opportunities and challenges for future directions. **Sci Rep** 15,5559 (2025),<https://doi.org/10.1038/s41598-025-90336-1> (*ISI-Thomson*)
- **Yacine Benchenina**, Abderrahim Zemmit, Mohammed Moustafa Bouzaki, Khaled Belhouchet. " A new improved of incorporating photovoltaic energy into the production of green hydrogen." **Diagnostyka** 25.2 (2024), <https://doi.org/10.29354/diag/187173> . (*Scopus*)

SCIENTIFIC COMMUNICATIONS

International

- **Yacine Benchenina**, Abderrahim Zemmit, Mohammed Moustafa Bouzaki. " New MPPT Control Methods for Grid Connected PV System to Produce Green Hydrogen" 1st International Conference on Recent Academic Studies ICRAS 2023.
- **Yacine Benchenina**, Abderrahim Zemmit, Mohammed Moustafa Bouzaki. " Integration of Renewable Energy in Green Hydrogen Generation" 1st International Conference on Scientific and Innovative Studies ICSIS 2023.
- **Yacine Benchenina**, Abderrahim Zemmit, Mohammed Moustafa Bouzaki. " Advanced Electrolyzer Modelisation for Green Hydrogen Production" International Conference on Environmental Engineering and Renewable Energy (ICENVERE - 23).

National

- **Yacine Benchenina**, Abderrahim Zemmit, Mohammed Moustafa Bouzaki. " Enhancing the Performance of Grid-Connected Photovoltaic Systems Through Storage Integration: A Techno-Economic and Environmental Study " 1st National Conference of Advanced Systems in Electrical Engineering (NCASEE'24).
- **Yacine Benchenina**, Abderrahim Zemmit, Mohammed Moustafa Bouzaki. " Utilizing Excess Solar Energy for Green Hydrogen Production in Algeria: A Feasibility Study " 1st National Conference of Advanced Systems in Electrical Engineering (NCASEE'24).

Acknowledgements

In the Name of Allah, the Most Gracious, the Most Merciful,
And may peace and blessings be upon our best of creation, our Prophet Muhammad, and
upon his family and companions.

First, I extend my highest expressions of gratitude and praise to Allah Almighty, who has bestowed His grace and care upon me; by His permission, my endeavors have come to fruition and this work has been accomplished. I cannot help but express my profound gratitude to my dear parents, who have been a guiding light and steadfast support at every step of my journey, especially my mother, who sacrificed everything for my happiness and provided unwavering encouragement. I pray that Allah rewards them abundantly, protects them, and grants my siblings success and prosperity.

I also wish to express my sincere thanks and appreciation to my research supervisors, Dr. Abderrahim Zemmit, Dr. Mohamed Moustafa Bouzaki, and Dr. Abdeloudoud Loukriz, for their invaluable guidance and enriching advice, which have formed the cornerstone of my academic journey. Their noble expertise and continuous support have had a profound impact on my intellectual and personal growth, and for this I remain eternally grateful.

I must not forget to extend my heartfelt thanks to all the friends and loved ones both near and far, who supported and encouraged me in every phase. Their kind words and steadfast support served as a driving force for perseverance and creativity.

In conclusion, I would like to offer a special note of gratitude to someone who, without even realizing it, enriched my journey and helped refine my character. Though our acquaintance was brief, I learned so much and found a purpose to strive for. Thank you very much, T. Chaima. I pray that Allah grants you success, protects you, and perpetuates your happiness, and I hope that we may meet again in the best of circumstances, God willing.

I conclude my message with these blessed words:

"You never know; perhaps Allah will bring about something after that."

Table of Contents

Chapter 1 Foundations of Renewable Energy & Green Hydrogen in Energy Transition.....	5
1.1 Background on the Global Energy Crisis	5
1.1.1 Growing Global Energy Demand	6
1.1.2 Climate Change and Its Impact on Energy Systems	8
1.1.3 Geopolitical Instabilities and Energy Security.....	10
1.1.4 Green Hydrogen as a Solution to the Energy Crisis	10
1.1.5 Green Hydrogen Market Size & Trends	12
1.2 Definition and Importance of Green Hydrogen	13
1.2.1 Definition of Green Hydrogen	13
1.2.2 Importance of Green Hydrogen	14
1.3 Algeria’s Position in the Renewable Energy Transition.....	16
1.4 Research Objectives and Significance	18
1.4.1 Research Objectives.....	18
1.4.2 Significance of the Research.....	19
1.5 Conclusion	20
Chapter 2 Renewable Resources and Energy Strategy in Algeria	22
2.1 Literature Review:	22
2.1.1 Overview of Global Advances in Renewable Energy:.....	22
2.1.2 Analysis and Commentary on the Reviewed Works:	29
2.2 Analysis of Renewable Energy Resources in Algeria.....	31
2.2.1 Solar Energy.....	31
2.2.2 Wind Energy	32
2.2.3 Water Resources	33
2.3 Strategic Analysis of Algeria’s Geographical Location.....	35
2.4 National Renewable Energy Strategy	35
2.4.1 Renewable Energy Strategy and Policies.....	35
2.4.2 Current Partnerships and Projects	37
2.5 Export Potential to European Markets	38
2.6 Socio-Economic Benefits.....	39
2.7 Current Challenges.....	39
2.8 Conclusion	41
Chapter 3 Advanced Systems for Green Hydrogen Production.....	43
3.1 Hydrogen Production Using Photovoltaic (PV) Energy	43
3.1.1 Overview of PV-Driven Hydrogen Production.....	43

Improving the performance of energy systems from renewable sources based on green hydrogen

List of Figure

3.1.2 Challenges in PV Systems for Hydrogen Production	44
3.1.3 Innovations in PV System Design	44
3.1.4 Advanced Electrolyzer Modeling	49
3.1.5 Simulation Results	57
3.1.6 Comment On The Results	62
3.1.7 Example Applications and Future Directions	62
3.1.8 Future Research Directions: Pioneering New Frontiers.....	66
3.2 Electrolysis Methods.....	66
3.2.1 Types of Electrolysis.....	67
3.2.2 Innovative Water Sourcing Solutions	68
3.2.3 Integration with Renewable Energy.....	69
3.2.4 Future Prospects and Recommendations	69
3.3 Utilizing Digital Twins to Enhance Fuel Cell Efficiency	70
3.3.1 Theoretical Foundations and Principles	70
3.3.2 Case Study: Advanced PEM Fuel Cell Digital Twin.....	71
3.3.3 Scientific Insights and Technological Implications	80
3.3.4 System Modeling and Load Analysis	80
3.3.5 Future Prospects and Research Directions	81
3.4 Integrating Storage Systems with Photovoltaic Grids	81
3.4.1 Key Storage Technologies	81
3.4.2 Techno-Economic and Environmental Considerations.....	82
3.4.3 Theoretical Foundations and Principles	82
3.4.4 System Design and Components.....	82
3.4.5 Simulation and Optimization using HOMER Pro.....	84
3.4.6 SIMULATION RESULTS:	85
3.5 Conclusion:	90
Chapter 4 : Advancing Green Hydrogen Production in Algeria.....	92
4.1 Summary of Previous Research on Green Hydrogen in Algeria	92
4.1.1 Hydrogen Production from Photovoltaics (PV).....	92
4.1.2 Wind Energy Integration.....	92
4.1.3 Hybrid Renewable Energy Systems.....	93
4.1.4 Concentrated Solar Power (CSP) and Hydrogen Production.....	93
4.1.5 Geographical Resource Mapping.....	93
4.2 4.2. Critical Gaps and Challenges	93
4.3 Relevance to Current Study	94
4.4 Simulation Tools and Methodologies	94
4.4.1 HOMER Pro Overview and Capabilities	94

Improving the performance of energy systems from renewable sources based on green hydrogen

List of Figure

4.4.2 Employed Methodology.....	94
4.4.3 Results And Discussions:.....	98
4.4.4 Strategic Advancements in Hydrogen Utilization and Exportation	104
4.5 Case Study: Feasibility of Expanding Solar Power for Green Hydrogen in M'Sila, Algeria....	109
4.5.1 Overview Of The System.....	109
4.5.2 System Operation.....	111
4.5.3 Simulation Results and Economic Analysis	112
4.5.4 Analysis Of Profitability	114
4.5.5 Commentary On Results And Implications	114
4.6 Cost and Efficiency Challenges	115
4.7 Sustainable Water Resource Utilization	116
4.8 Integrating Renewable Energy into the National Grid.....	116
4.9 Summary of Key Findings	117
4.10 Recommendations for Developing Green Hydrogen in Algeria.....	117
4.11 Future Research Directions.....	118
4.12 Conclusion	119
General Conclusion.....	121
Future Perspectives and Directions.....	122
Bibliography	123

List of Figures

Figure 1-1 Global Energy Consumption Over the Last Two Decades (Source : Statista)	6
Figure 1-2 Changes in global electricity generation, 2022-2026	6
Figure 1-3 Primary Energy Consumption by World Region	8
Figure 1-4 Temperature Anomalies (2023 vs. Pre-Industrial Levels	9
Figure 1-5 Impact of Climate Change on Energy Systems	9
Figure 1-6 European Dependence on Russian Gas (2022)	10
Figure 1-7 Green Hydrogen Production Process	12
Figure 1-8 Green Hydrogen Market Size 2023-2033 (USD Billion)	12
Figure 1-9 Green Hydrogen Market Share by Application 2024	13
Figure 1-10 Main Shades of Hydrogen	14
Figure 1-11 Green Hydrogen Applications Across Sectors.....	15
Figure 1-12 Algeria’s strategic Mediterranean location and its gas pipelines to Europe.....	17
Figure 1-13 Comparing solar irradiation levels between Algeria and other regional countries .	17
Figure 1-14 hydrogen production potential from solar energy	18
Figure 2-1 Solar Irradiance Map of Algeria	32
Figure 2-2 Annual Wind Speed Distribution in Algeria	33
Figure 2-3 Algeria’s Water Resources Overview	34
Figure 2-4 Algeria’s Energy Export Infrastructure	35
Figure 2-5 Progress of Algeria’s Renewable Energy Goals (2020–2030)	36
Figure 2-6 the Renewable Energy Development Program (2015-2030)	37
Figure 2-7 Green hydrogen exports targeting EU markets in 2030	38
Figure 3-1 The Used System.....	45
Figure 3-2 Electric model of solar cell.....	47
Figure 3-3 Typical Power-Voltage characteristic.....	48
Figure 3-4 Perturbation and observation control algorithm	49
Figure 3-5 Schematic representation of Electrolyzer and Fuel Cell	53
Figure 3-6 Advanced Electrolyzer Simulation	55
Figure 3-7 Advanced Electrolyzer MATLAB Model.....	56
Figure 3-7 Power Source Profiles	56
Figure 3-9 Temporal Variation of Irradiance	58
Figure 3-10 Photovoltaic System Power Output	58
Figure 3-11 Photovoltaic System Voltage Output	58
Figure 3-12 Battery charging current	59
Figure 3-13 Battery voltage.....	59
Figure 3-14 Solar Power Profile Graphs.....	60
Figure 3-15 Step Profile Graphs	61
Figure 3-16 Ramp ProfileGgraphs	61
Figure 3-17 Bifacial vs. Monofacial Panels.....	63
Figure 3-18 Advanced cooling systems for PV panels	65
Figure 3-19 Diagram of a hybrid PV-wind system	65
Figure 3-20 Types of Electrolysers	68
Figure 3-20 Water Electrolysis Process Using Renewable Energy	69
Figure 3-22 Advanced Fuel Cell MATLAB Model	76

Improving the performance of energy systems from renewable sources based on green hydrogen
List of Figure

Figure 3-23 Advanced Fuel Cell MATLAB Model	77
Figure 3-24 Load Profiles	77
Figure 3-25 Drive Cycle Profile graphs.....	78
Figure 3-26 Step Profile graphs	79
Figure 3-27 Ramp Profile graphs	79
Figure 3-28 Illustration of the designed system.....	83
Figure 3-29 Electricity demand profile	84
Figure 3-30 Electricity demand profile	85
Figure 3-31 Homer Simulation results	86
Figure 3-32 Base case comparison and lowest-cost system	87
Figure 3-33 Three Systems Emissions.....	87
Figure 3-34 Electrical performance of the lowest-cost system.....	88
Figure 3-35 Insights from HOMER simulation results	89
Figure 3-36 Comparison of PV/Battery/Grid system with the base case (Grid)	89
Figure 3-37 Detailed emissions of PV/B/Grid system	90
Figure 4-1 Diagram of a PV-Electrolyzer-Fuel Cell Power System	95
Figure 4-2 Diagram of a PV-Electrolyzer- Battery Power System.....	96
Figure 4-3 Comparative Photovoltaic Electricity Generation in Various Locations Worldwide	99
Figure 4-4 Comparative Hydrogen Production in Various Locations Worldwide.....	100
Figure 4-5 Comparative Hydrogen Production in various geographic locations in Algeria.....	100
Figure 4-6 Comparative Hydrogen Production in Various Locations Worldwide.....	101
Figure 4-7 A comparison of the characteristic of WWTPs managed by the NSO in 2009.....	103
Figure 4-8 The progression of wastewater production that are equipped with dams	103
Figure 4-9 Comparative Levelized Cost of Hydrogen in Various Locations Worldwide.....	105
Figure 4-10 Leveraging Existing Infrastructure for Green Hydrogen Export in Algeria	106
Figure 4-11 Hydrogen Production and Consumption by Region (Kg/year).....	107
Figure 4-12 Illustration of the designed system.....	110
Figure 4-13 Electricity demand profile	111
Figure 4-14 Variation in solar radiation and clearness index.....	112
Figure 4-15 Monthly electricity generation Compression.....	112
Figure 4-16 System Emissions.....	113
Figure 4-17 Green Hydrogen Prices in 2023.....	113
Figure 4-18 Green,Gray and Blue Hydrogen Prices in 2023	114

List of Tables

Table 1-1 Regional Energy Demand Trends	7
Table 1-2 Half-cell reactions, typical temperature ranges, and ionic charge carriers for different types of water electrolysis	11
Table 1-3 Green Hydrogen vs. Fossil Fuels: Environmental and Economic Benefits	15
Table 2-1 Content of the Renewable Energy Development Program	37
Table 2-2 Challenges and Proposed Solutions for Algeria’s Renewable Energy Sector	40
Table 3-1 Physical Parameters Used for the Electrolyzer	55
Table 3-2 PV Model Characteristics	57
Table 3-3 Efficiency comparison of bifacial vs. Monofacial panels	64
Table 3-4 Comparison of Electrolysis Methods	67
Table 3-5 Physical Parameters Used for the Fuel Cell	76
Table 3-6 Specifications of PV panels	83
Table 3-7 Specifications of battery storage	83
Table 3-8 Specifications of power electronic converters	84
Table 4-1 System specifications	96
Table 4-2 Specifications of PV panels	109
Table 4-3 Specifications of battery storage	110
Table 4-4 Specifications of power electronic converters	110
Table 4-5 Specifications of Electrolyzer	110

List of Abbreviations

AE	Alkaline Electrolysis
AI	Artificial INTELLIGENCE
CAGR	Compound Annual Growth Rate
CI	Continental Interlayer
CPV	Concentrator Photovoltaic
CPV-E	Concentrator Photovoltaic Electrolysis
DC	Direct Current
DCX	Dc-Dc CONVERTER
DNI	Direct Normal Irradiance (
EL	Electrolyzer
EU	European Union
FC	Fuel Cell
FCEV	FUEL CELL Electric VEHICLES
G2G	Green TO Green
HER	Hydrogen Evolution Reaction
IEA	International Energy Agency
IoT	Internet OF Things
IRENA	International Renewable Energy Agency
LCOE	Levelized Cost OF Electricity
LCOH	Levelized Cost OF HYDROGEN
MEG	Maghreb-Europe Gas Pipeline
MPPT	Maximum Power Point Tracking
NOAA	National Oceanic AND Atmospheric Administration
NREAP	National Renewable Energy AND Energy Efficiency Program
OER	Oxygen Evolution Reaction
PV	Photovoltaic
PEM	Proton Exchange Membrane
PEC	Photoelectrochemical
PEMFC	Proton Exchange Membrane Fuel Cells (
PSO	Particle Swarm Optimization
P&O	Perturbation AND OBSERVATION
ROI	Return On Investment
SPE	Solid Polymer Electrolysis
SOE	Solid Oxide Electrolyte
STH	Solar-To-Hydrogen
TNPC	Total Net Present Cost
TC	Terminal Complex
TES	Thermal Energy Storage



**General Introduction to
the Dissertation**

General Introduction to the Dissertation

The global energy landscape is undergoing a profound transformation, driven by the urgent need to address climate change, depleting fossil fuel reserves, and energy security challenges. This transition marks a pivotal moment in the pursuit of sustainable development, where renewable energy solutions are at the forefront of mitigating environmental and economic risks. [1] Among these solutions, **green hydrogen** has emerged as a game-changing energy carrier due to its ability to provide a clean, versatile, and sustainable alternative to traditional fossil fuels. Produced through the electrolysis of water using renewable energy sources such as solar and wind, green hydrogen presents a tangible opportunity to decarbonize sectors traditionally dependent on fossil fuels, including transportation, heavy industry, and power generation. [2]

Algeria, endowed with abundant and largely untapped renewable energy resources, particularly photovoltaic (PV) solar energy, holds a unique position in this global energy transition. Strategically located with one of the world's highest levels of solar irradiance [3], Algeria has the potential to become a cornerstone in the emerging green hydrogen economy. Leveraging its vast natural resources, existing energy infrastructure, and geographical proximity to European markets seeking sustainable energy imports, Algeria can play a critical role in addressing both domestic and international energy demands [4].

This dissertation, titled "**Improving the Performance of Energy Systems from Renewable Sources Based on Green Hydrogen**," delves into the multifaceted dimensions of integrating green hydrogen into Algeria's energy ecosystem. It examines the technical, economic, and environmental implications of this integration while seeking innovative solutions to optimize hydrogen production and utilization. Employing advanced modeling and simulation tools, such as **HOMER Pro** and **MATLAB Simulink**, the research evaluates photovoltaic productivity, electrolysis performance, and fuel cell efficiency under diverse operational conditions. In addition, the study explores the potential of employing seawater electrolysis and wastewater treatment as sustainable water sources, addressing critical challenges associated with hydrogen production in water-scarce regions.

Beyond the technical aspects, this dissertation highlights the broader socio-economic and environmental benefits of green hydrogen adoption in Algeria. By positioning the country as a leader in renewable energy innovation, the research underscores the potential for economic diversification, job creation, and enhanced energy security. Furthermore, it aligns with global

Improving the performance of energy systems from renewable sources based on green hydrogen

General Introduction

efforts to combat climate change, contributing to Algeria's commitments under international frameworks such as the Paris Agreement.

Through a comprehensive analysis and forward-looking strategies, this study aspires to bridge theoretical research with practical applications. It emphasizes the importance of fostering synergies between renewable energy technologies and innovative water management approaches, ensuring the sustainability and scalability of green hydrogen systems. Ultimately, this dissertation seeks to underscore the pivotal role of green hydrogen in shaping a resilient, low-carbon, and economically vibrant energy future for Algeria and beyond.

The first chapter reviews the global energy crisis caused by rising demand, climate change, and supply instability. It highlights green hydrogen as an innovative solution to energy challenges. The chapter explains how green hydrogen is produced using renewable energy sources and emphasizes its potential to reduce carbon emissions and meet energy demand in Algeria.

Chapter 2 provides a comprehensive review of key research on green hydrogen production, integrating insights from both global and regional perspectives. It begins with an analysis of methods aimed at enhancing the efficiency of renewable energy systems and explores various storage and production techniques crucial to advancing the green hydrogen sector. The chapter emphasizes the significance of international collaboration in fostering the development of this industry within Algeria. Additionally, the analysis of Algeria's renewable energy resources solar, wind, and hydro, illustrates the country's potential for producing and exporting green hydrogen. By examining current international partnerships and proposing strategic enhancements, the chapter underscores Algeria's strategic positioning in the global energy landscape.

Chapter 3 is focusing on the challenges and innovative solutions in green hydrogen development and energy system performance enhancement in Algeria. It begins by examining the technical, economic, and environmental challenges facing green hydrogen projects, including water scarcity and high production costs. The chapter proposes advanced solutions, such as seawater electrolysis and advanced storage technologies, aimed at improving the economic viability and sustainability of green hydrogen production in Algeria.

Improving the performance of energy systems from renewable sources based on green hydrogen

General Introduction

Moving forward, the chapter explores innovative techniques to enhance energy system performance, including the use of digital twins to optimize fuel cell efficiency and the integration of storage systems with photovoltaic grids. These advancements are crucial for maximizing energy efficiency, reducing costs, and ensuring a stable energy supply amidst the transition towards sustainable energy solutions.

The final chapter integrates environmental and economic analyses of green hydrogen production in Algeria, addressing key challenges, proposing solutions, and presenting conclusions and recommendations. It highlights the dual benefits of green hydrogen, emphasizing its potential to reduce greenhouse gas emissions while generating financial savings through investments in clean technologies. The challenges include high costs, inefficiencies in advanced systems, and limited freshwater resources, necessitating innovative solutions such as technological advancements, seawater desalination, and expanded storage capacities to ensure grid stability.

The memorandum concludes with a set of key recommendations, including the reinforcement of local scientific research, the expansion of desalination projects, and the modernization of infrastructure to position Algeria as a leading global hub for green hydrogen. It also underscores the importance of international collaboration to ensure sustainable development. Furthermore, the memorandum outlines future directions and strategic objectives that will be explored in subsequent studies, aiming to refine this vision and enhance the synergy between technical, economic, and environmental aspects of this promising sector.

Chapter 1:
**Foundations of Renewable
Energy & Green Hydrogen in
Energy Transition**

Chapter 1 Foundations of Renewable Energy & Green Hydrogen in Energy Transition

The global energy landscape is at a critical juncture, shaped by escalating challenges such as climate change, depleting fossil fuel reserves, and increasing energy demand. These issues necessitate a paradigm shift toward sustainable and renewable energy solutions that address both environmental and economic concerns. Among these solutions, green hydrogen has emerged as a transformative energy carrier, offering a clean, versatile, and scalable alternative to traditional fossil fuels [1].

Green hydrogen, produced through the electrolysis of water powered by renewable energy sources like solar and wind, has the potential to decarbonize key sectors such as transportation, heavy industry, and power generation. Its adoption represents a crucial step toward achieving global climate goals and ensuring long-term energy security [2].

This chapter explores the foundational concepts of renewable energy and the pivotal role of green hydrogen in addressing the global energy crisis. It examines the interplay between rising energy demand, climate change, and geopolitical instabilities, emphasizing the necessity of transitioning to renewable energy systems. The chapter also highlights the growing market for green hydrogen, its technological underpinnings, and its importance in driving the global shift toward sustainability.

By providing a comprehensive overview of green hydrogen's potential and its relevance to Algeria, this chapter sets the stage for understanding how renewable energy integration can position the country as a leader in the emerging green hydrogen economy.

1.1 Background on the Global Energy Crisis

The global energy crisis is marked by a convergence of rising demand, environmental challenges, and geopolitical tensions. Addressing these interconnected issues requires transitioning to sustainable energy sources, with green hydrogen emerging as a transformative solution. This section explores the underlying factors driving the crisis and the potential of renewable energy to mitigate its impact, particularly in the context of Algeria's unique resources.

1.1.1 Growing Global Energy Demand

Global energy consumption has increased by approximately 25% over the last two decades, driven by rapid population growth, industrialization, and technological advances. The International Energy Agency (IEA) predicts that global energy demand will continue to rise significantly, particularly in developing countries, where energy access remains a critical challenge. Sub-Saharan Africa, for example, is projected to see a 40% increase in energy demand by 2040 due to urbanization and economic expansion. [5]

This relentless growth places immense pressure on finite fossil fuel resources, exacerbating energy insecurity and environmental degradation. For Algeria, where energy demand is rising alongside domestic industrial growth, this situation underscores the need for alternative energy sources like solar and green hydrogen.

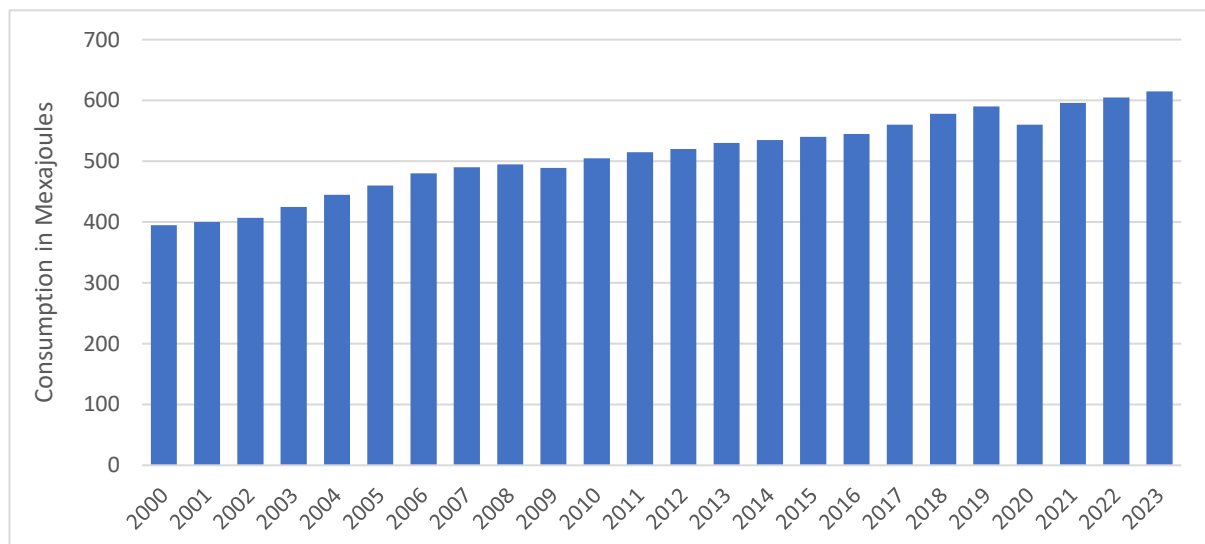

Figure 1-1 Global Energy Consumption Over the Last Two Decades (Source : Statista) [6]

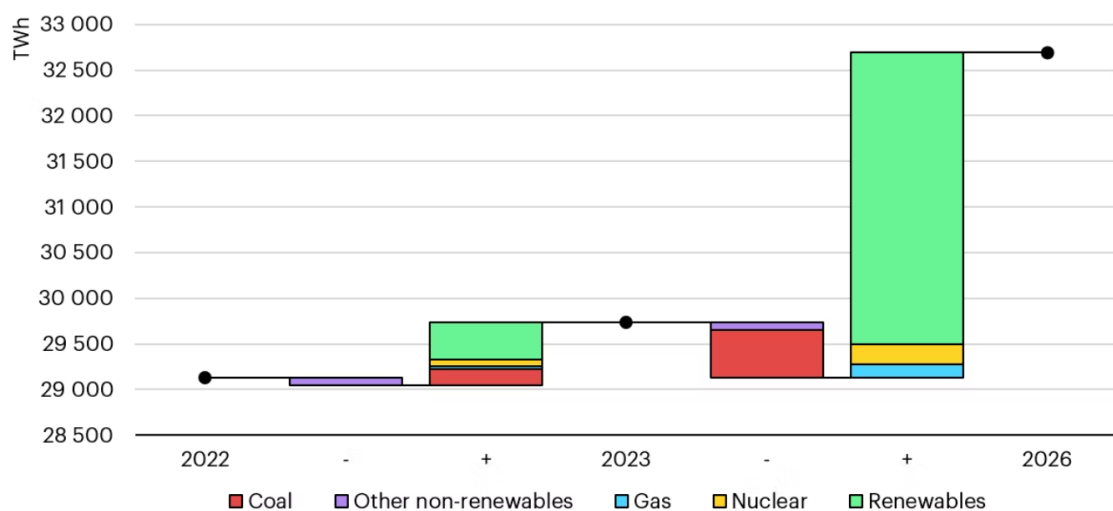

Figure 1-2 Changes in global electricity generation, 2022-2026 [7]

Table 1-1 Regional Energy Demand Trends [8]

Region	Annual Energy Demand Growth Rate	Key Drivers
Developing Regions	2-3% (2010-2023)	Rapid population growth, industrialization, urbanization
Sub-Saharan Africa	2.5% (2020-2023)	Urban expansion, limited energy access
South and East Asia	2-3.5% (2010-2023)	Economic growth, technological advancement
Developed Regions	0.5%-1% (2010-2023)	Energy efficiency improvements, economic saturation
North America	0.6% (2020-2023)	Increased renewable adoption, slower demand growth
Europe	0.4%-0.7% (2010-2023)	Transition to renewables, energy policy reforms

Highlights:

1. **Developing Regions** like Sub-Saharan Africa and South Asia experience higher energy demand growth rates due to rapid industrialization and population growth.
2. **Developed Regions**, including Europe and North America, show significantly lower growth rates due to advancements in energy efficiency and saturation in consumption patterns.
3. Renewable energy integration is a common trend across most regions, impacting growth rates.

Primary energy consumption by world region

Primary energy¹ consumption is measured in terawatt-hours², using the substitution method³.

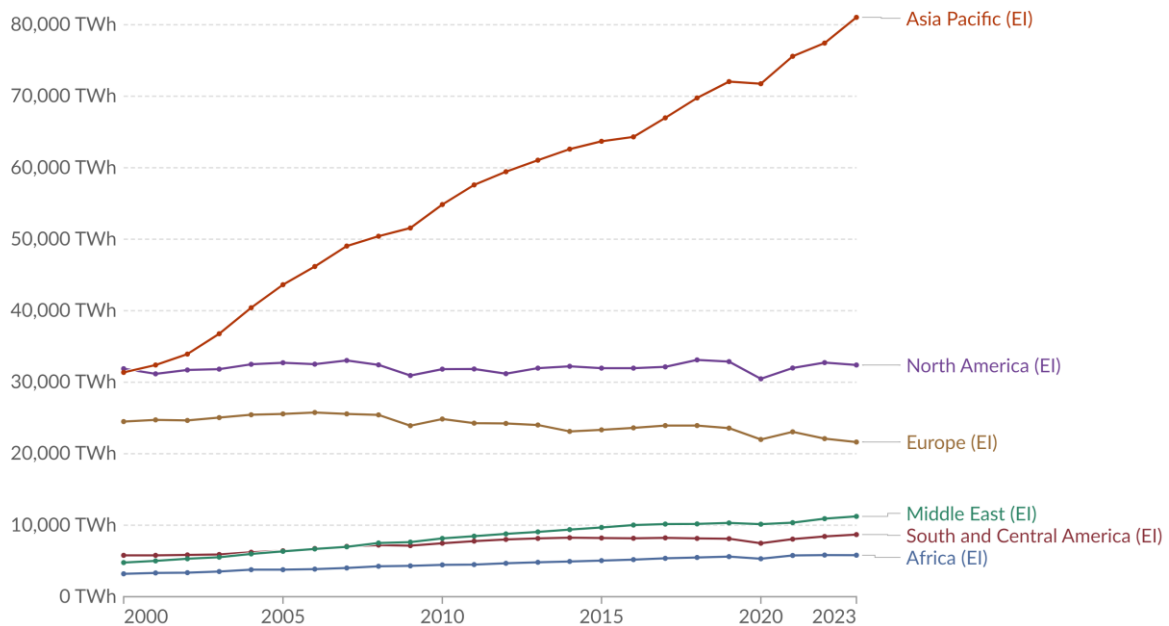

Data source: Energy Institute - Statistical Review of World Energy (2024)

OurWorldinData.org/energy | CC BY

Note: The data includes only commercially-traded fuels (coal, oil, gas), nuclear and modern renewables used in electricity production, but not traditional biomass.

Figure 1-3 Primary Energy Consumption by World Region [9]

1.1.2 Climate Change and Its Impact on Energy Systems

The effects of climate change amplify the urgency to transition to renewable energy. The year 2023 set alarming records, with global temperatures exceeding pre-industrial levels by 1.0°C. Data from NOAA shows an increase in extreme weather events such as hurricanes, droughts, and wildfires, which strain traditional energy infrastructures, causing disruptions and increasing operational costs. [10]

This global challenge makes renewable energy indispensable. Green hydrogen, derived from renewable sources, offers a resilient and sustainable alternative to traditional fuels. For instance, Denmark has successfully integrated green hydrogen into its energy grid, enhancing climate resilience while reducing emissions. Algeria, with its abundant solar resources, is similarly positioned to mitigate climate risks through renewable energy adoption.

Average temperature anomaly, Global

Global average land-sea temperature anomaly relative to the 1961-1990 average temperature baseline.

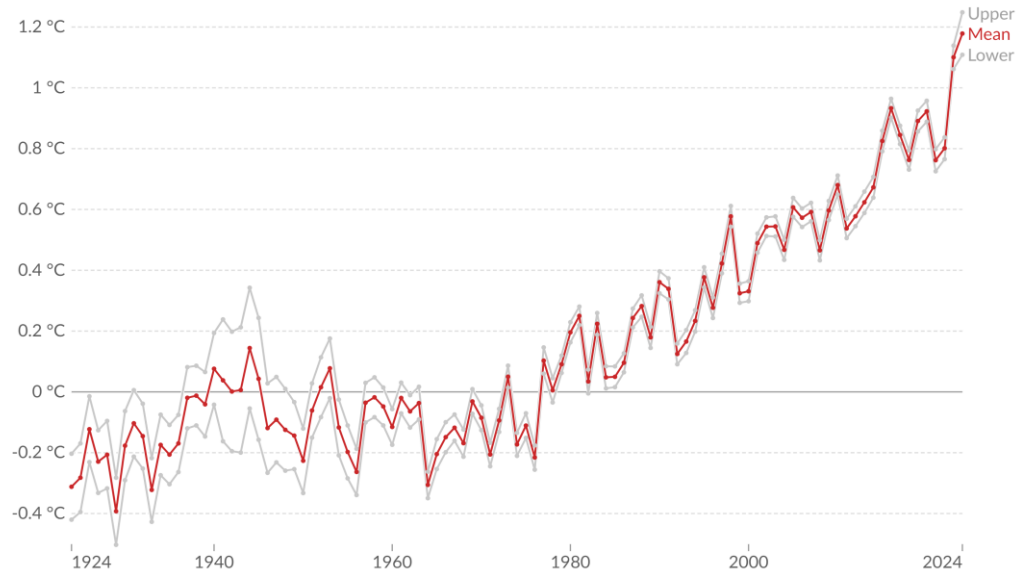

Data source: Met Office Hadley Centre (2024)

OurWorldinData.org/co2-and-greenhouse-gas-emissions | CC BY

Note: The gray lines represent the upper and lower bounds of the 95% confidence interval.

Figure 1-4 Temperature Anomalies (2023 vs. Pre-Industrial Levels) [11]

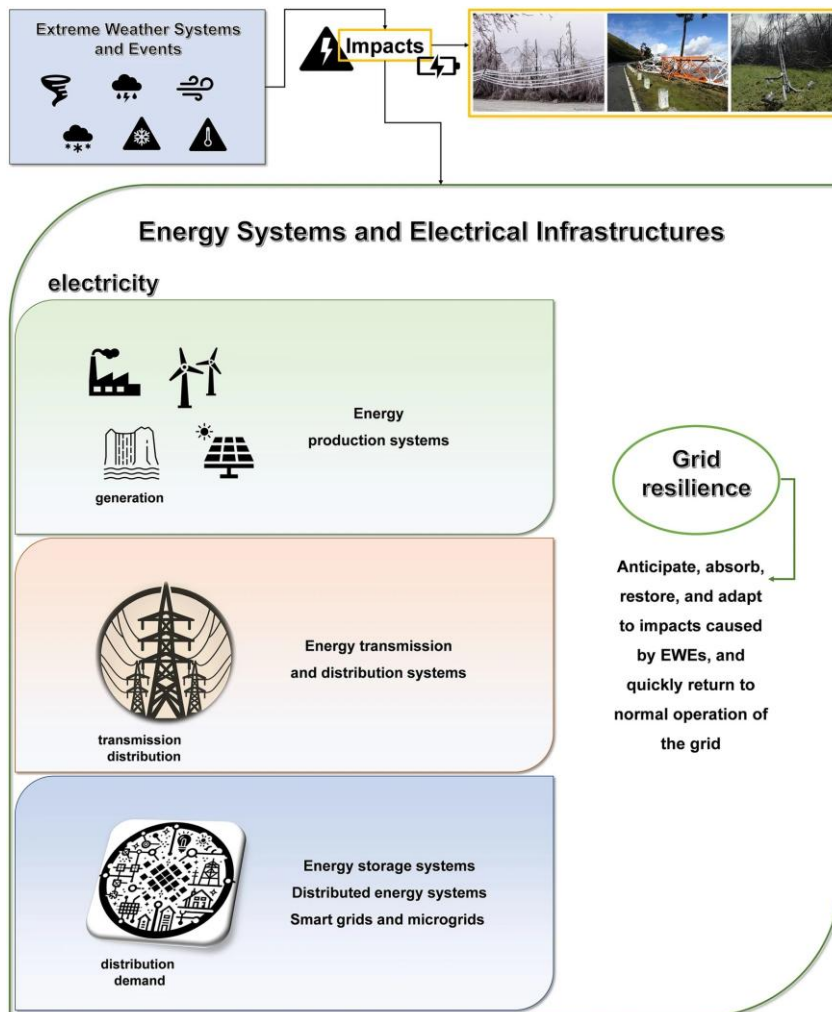

Figure 1-5 Impact of Climate Change on Energy Systems

1.1.3 Geopolitical Instabilities and Energy Security

Geopolitical events, such as the Ukraine conflict, have exposed vulnerabilities in the global energy supply chain. Europe, heavily reliant on Russian gas, experienced a 40% reduction in gas imports during the crisis, leading to soaring energy prices and supply shortages. This has reinforced the need for energy diversification and highlighted the potential of countries like Algeria to contribute to global energy security. [12]

Algeria's strategic location and extensive solar potential make it a key player in supplying green hydrogen to Europe. Collaborations with the EU on renewable energy projects, such as integrating hydrogen pipelines, can bolster Algeria's role in stabilizing regional energy markets while reducing dependence on fossil fuels.

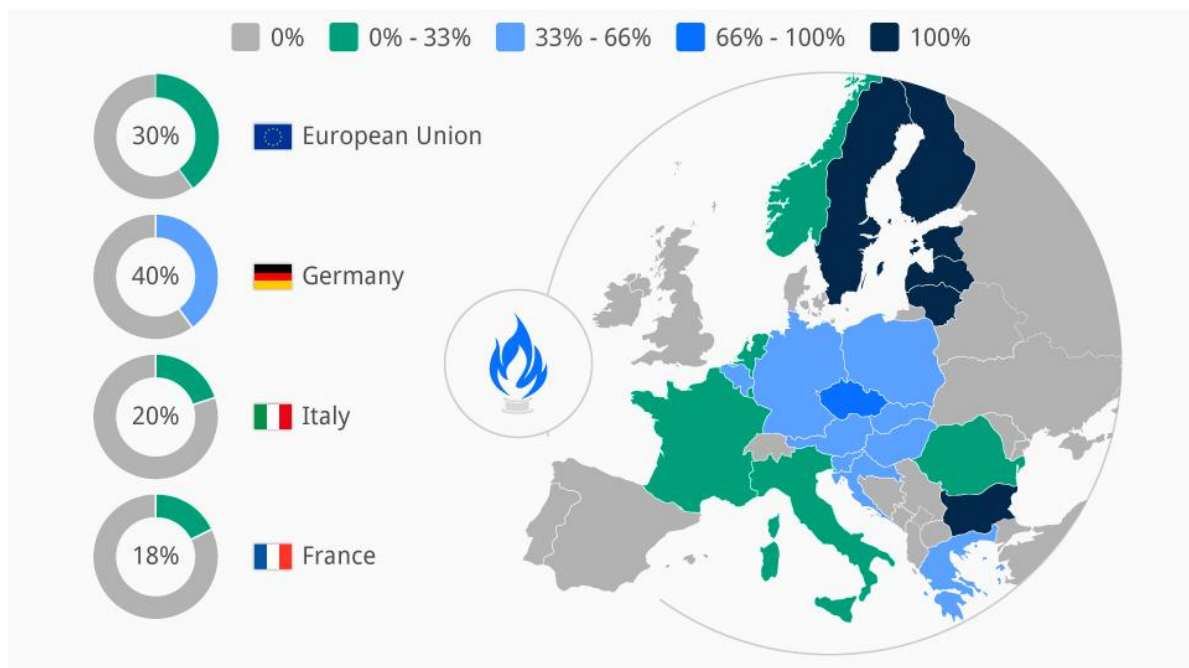
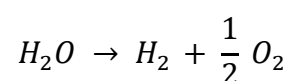

Figure 1-6 European Dependence on Russian Gas (2022) [13]

1.1.4 Green Hydrogen as a Solution to the Energy Crisis

Green hydrogen represents a breakthrough in addressing the global energy crisis. It is produced through the electrolysis of water using renewable energy, emitting only oxygen as a by-product. This makes it a zero-emission fuel suitable for decarbonizing various sectors, including transportation, industry, and power generation. [14]



Three primary technologies can be categorized based on the type of electrolyte used in electrolysis cells:

- **Alkaline electrolysis:** employs a liquid electrolyte.
- **Polymer Electrolyte Membrane (PEM) electrolysis:** utilizes an acidic ionomer electrolyte and is often referred to as Solid Polymer Electrolysis (SPE).
- **High-Temperature (SOE) steam electrolysis:** uses a solid oxide electrolyte.

Despite the differences, the core process in all three technologies remains consistent. Water is introduced into an electrochemical cell, where hydrogen is generated at the cathode (negative electrode) and oxygen at the anode (positive electrode) when an adequate voltage is applied. The anode and cathode are not separated by a diaphragm or membrane, and the oxygen and hydrogen gases accumulate in the space above the electrolysis cell. [15]

A detailed comparison of the hydrogen evolution reaction (HER), the oxygen evolution reaction (OER), the typical operating temperature range, and the ions acting as charge carriers through the diaphragm or membrane is presented in **Table 1-2**.

Table 1-2 Half-cell reactions, typical temperature ranges, and ionic charge carriers for different types of water electrolysis [15]

Technology	Temperature (K)	Cathode (HER)	Charge carrier	Anode (OER)
Alkaline electrolysis	333–363	$\text{H}_2\text{O} + 2\text{e}^- \rightarrow \text{H}_2 + 2\text{OH}^-$	OH^-	$2\text{OH}^- \rightarrow 1/2\text{O}_2 + \text{H}_2\text{O} + 2\text{e}^-$
PEM electrolysis	293–373	$2\text{H}^+ + 2\text{e}^- \rightarrow \text{H}_2$	H^+	$\text{H}_2\text{O} \rightarrow 1/2\text{O}_2 + 2\text{H}^+ + 2\text{e}^-$
SOE steam electrolysis	973–1273	$\text{H}_2\text{O} + 2\text{e}^- \rightarrow \text{H}_2 + \text{O}^{2-}$	O^{2-}	$\text{O}^{2-} \rightarrow 1/2\text{O}_2 + 2\text{e}^-$

For Algeria, green hydrogen presents an opportunity to leverage its solar irradiation levels of 2,000–3,000 kWh/m²/year to develop a sustainable energy economy. By investing in green hydrogen infrastructure, Algeria can reduce domestic reliance on hydrocarbons and position itself as a key exporter to Europe. Germany’s hydrogen strategy, which includes investments

in North African hydrogen projects, provides a compelling example of how such partnerships can be mutually beneficial. [4]

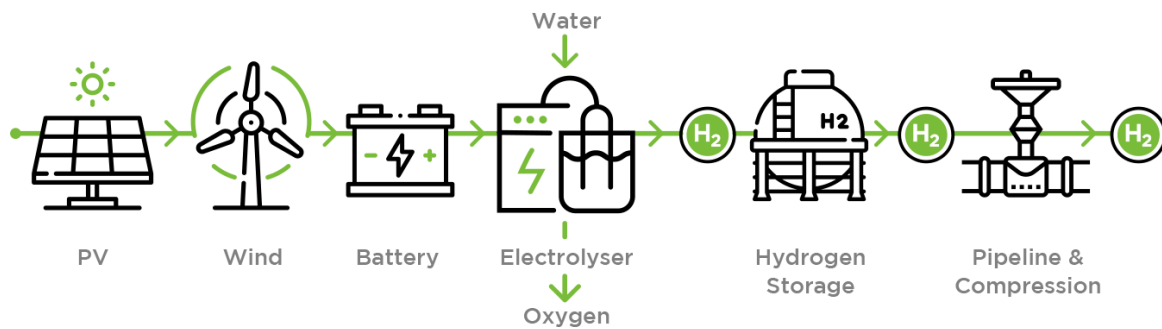

Figure 1-7 Green Hydrogen Production Process

1.1.5 Green Hydrogen Market Size & Trends

The global green hydrogen market was valued at approximately USD 7.98 billion in 2024 and is anticipated to experience remarkable growth over the coming years. Analysts project a compound annual growth rate (CAGR) of 38.5% from 2025 to 2030. This rapid expansion is attributed to several key factors, including increasing global efforts to transition toward cleaner energy systems, heightened investments in renewable energy infrastructure, and the growing demand for sustainable hydrogen in various industries such as transportation, chemicals, and power generation. [16]

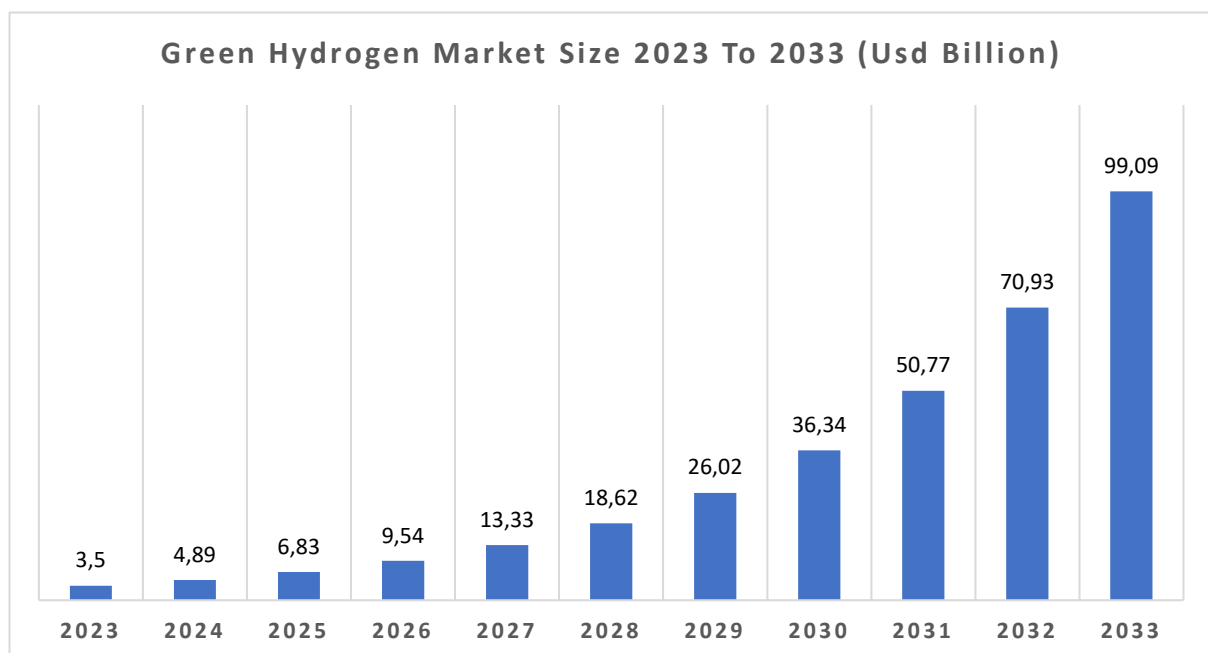

Figure 1-8 Green Hydrogen Market Size 2023-2033 (USD Billion) [17]

In 2024, the transportation sector led the green hydrogen market, capturing the largest revenue share of 43.39%. Hydrogen is utilized in transportation either through fuel cells or internal combustion engines. Hydrogen fuel cells are notably efficient, offering two to three times the energy efficiency of gasoline-powered internal combustion engines. However, burning hydrogen in traditional engines generates nitrogen oxide emissions and operates with lower efficiency compared to fuel cells, making the latter a more sustainable choice. [17]

By 2020, leading European automotive manufacturers such as CNH, Daimler, DAF, Ford, MAN, Scania, and Volvo had unveiled ambitious plans to transition their truck fleets to hydrogen power by 2040. Meanwhile, Airbus is actively developing hydrogen-powered aircraft, aiming to initiate commercial operations by 2035. Furthermore, advancements in smart grid technology and the increasing demand for enhanced grid stability are driving the adoption of green hydrogen within the utilities sector. This highlights its crucial role in ensuring reliable and efficient operations across electrical networks. [16]

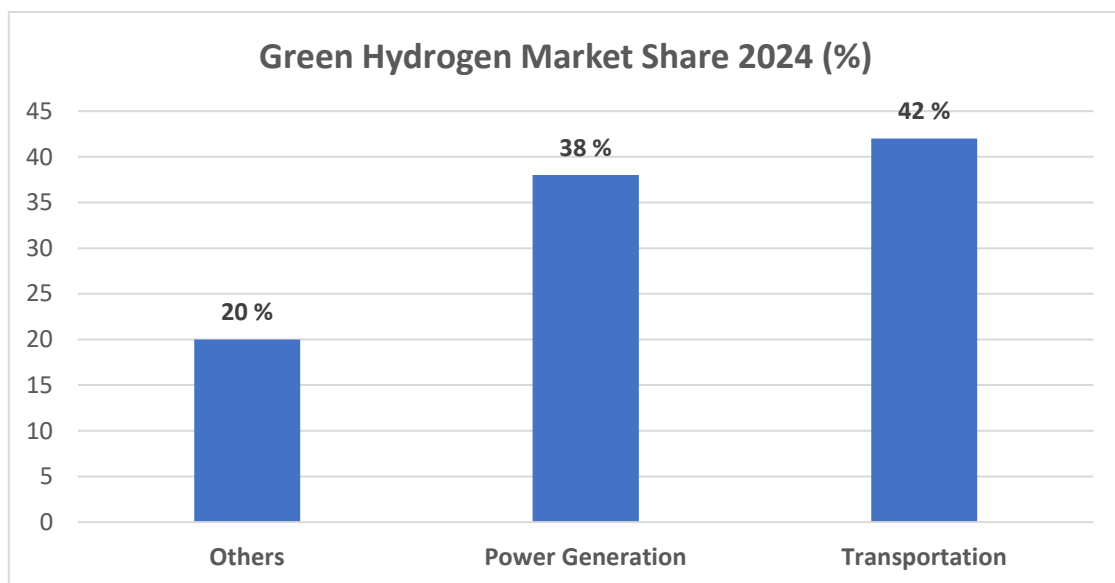

Figure 1-9 Green Hydrogen Market Share by Application 2024 [17]

1.2 Definition and Importance of Green Hydrogen

1.2.1 Definition of Green Hydrogen

Green hydrogen is hydrogen produced through the electrolysis of water, powered by renewable energy sources like solar, wind, or hydroelectric power. Unlike conventional hydrogen production, which depends on fossil fuels and emits significant CO₂, green hydrogen is a clean, sustainable fuel. The electrolysis process splits water into hydrogen and oxygen, with the latter being the only by-product. [18]

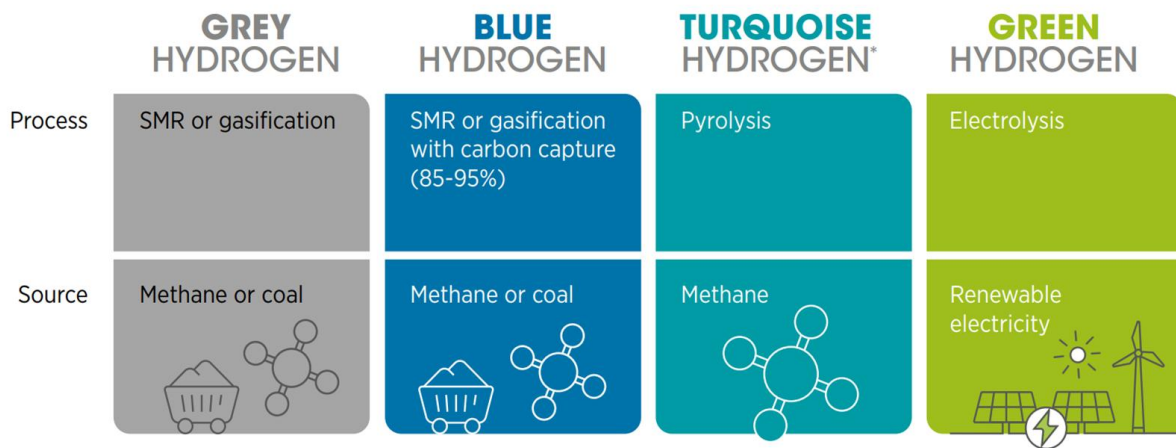

Figure 1-10 Main Shades of Hydrogen

1.2.2 Importance of Green Hydrogen

Green hydrogen is pivotal in addressing global energy challenges and decarbonizing sectors that are difficult to electrify directly [18]. Its importance spans several areas:

1. **Industrial Decarbonization:** Green hydrogen can replace coal and natural gas in steelmaking, cement production, and chemical processing, reducing carbon emissions from these hard-to-abate sectors.
2. **Energy Storage:** Hydrogen acts as an energy carrier, storing excess electricity generated by solar and wind farms. This stabilizes grids and addresses renewable energy intermittency.
3. **Transportation:** Hydrogen fuel cells provide a clean alternative for vehicles, especially in heavy-duty sectors like trucking, shipping, and aviation. Countries like Japan are at the forefront of deploying hydrogen fuel cell vehicles (FCEVs).
4. **Energy Security:** Countries with abundant renewable resources, such as Algeria, can reduce reliance on fossil fuel imports by producing green hydrogen domestically.
5. **Global Climate Goals:** Green hydrogen aligns with the objectives of the Paris Agreement, enabling nations to meet net-zero emission targets by mid-century.

Improving the performance of energy systems from renewable sources based on green hydrogen
 Chapter 1: Foundations of Renewable Energy & Green Hydrogen in Energy Transition

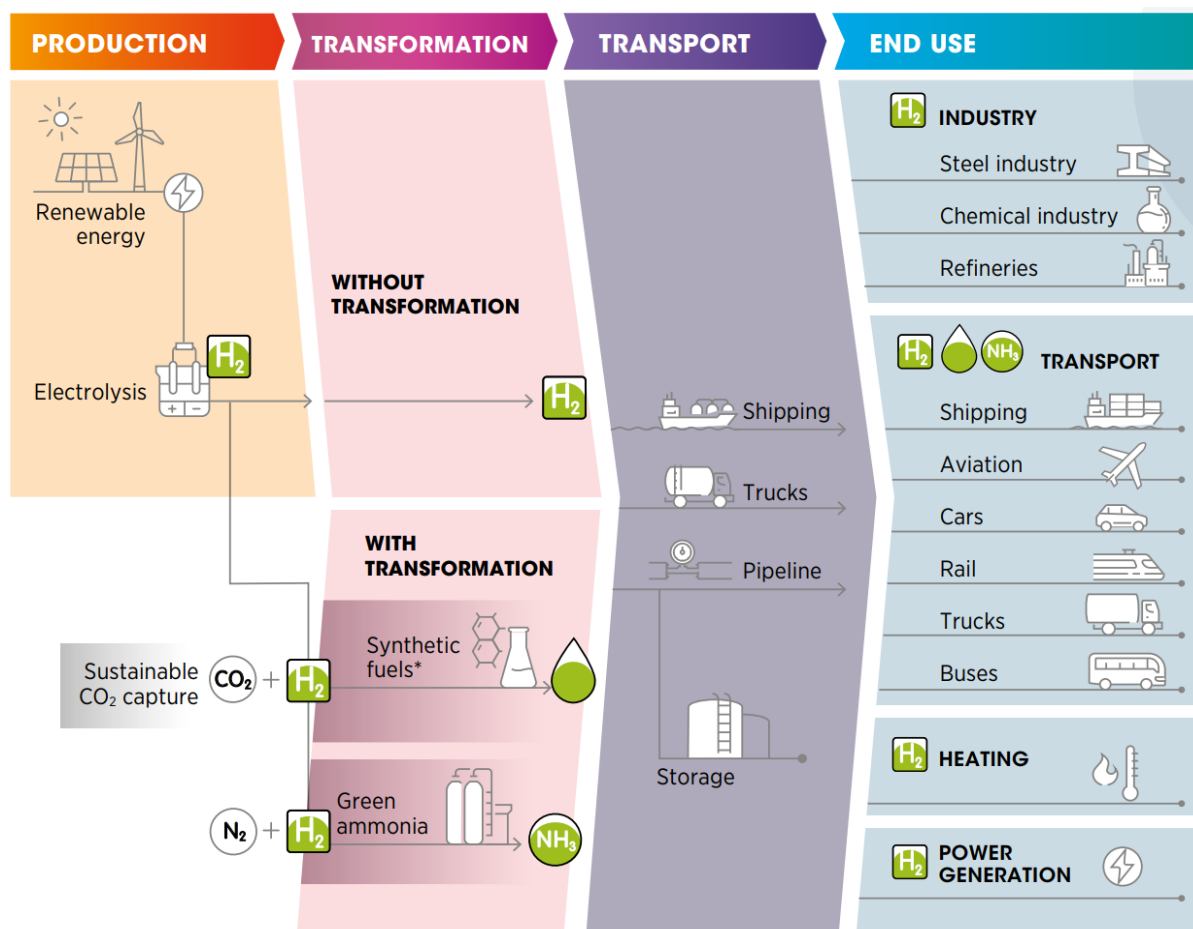

Figure 1-11 Green Hydrogen Applications Across Sectors

*Table 1-3 Green Hydrogen vs. Fossil Fuels: Environmental and Economic Benefits [19]
 [20]*

Feature	Green Hydrogen	Fossil Fuels
Environmental Impact	Zero emissions during use; only water vapor as a by-product. Greenhouse gas emissions reduced by up to 73% in energy systems.	High emissions, contributing to 73% of global GHG emissions and air pollution
Energy Efficiency	Fuel cells operate at 50%-60% efficiency, 2-3 times more efficient than internal combustion engines.	Internal combustion engines typically achieve efficiencies of 25%-30%
Sustainability	Produced using renewable energy sources like wind and solar, ensuring long-term availability.	Finite resource, subject to depletion, and extraction damages ecosystems

Safety	Hydrogen has advanced safety standards; spills disperse quickly without contamination.	Oil spills and natural gas leaks cause long-term environmental damage
Versatility	Can be used in multiple sectors: transportation, industrial processes, and energy storage.	Primarily limited to transportation and energy generation
Economic Potential	Expected to generate significant investments and green jobs as the industry scales up.	Job creation is less dynamic and tied to finite resources
Impact on Air Quality	No particulate emissions, improving air quality in urban areas.	Produces particulate matter, worsening urban air pollution and health problems

1.3 Algeria’s Position in the Renewable Energy Transition

Algeria's strategic location positions it as a potential leader in the global shift toward sustainable energy, offering significant advantages for both domestic and international energy transition initiatives. Situated along the southern coast of the Mediterranean, Algeria benefits from proximity to Europe, one of the world's largest energy markets, which is increasingly prioritizing renewable energy and green hydrogen to achieve carbon neutrality by 2050. [21]

In terms of natural resources, Algeria boasts exceptional solar energy potential. The vast Algerian Sahara, covering over 80% of the country's territory, experiences some of the highest solar irradiation rates globally, exceeding 6 kWh/m²/day in many regions and offering more than 3,000 hours of sunlight annually. This makes Algeria an ideal candidate for solar energy projects that can serve as a foundation for green hydrogen production. [21]

From an infrastructure perspective, Algeria is equipped with an extensive gas pipeline network that directly connects it to Europe through systems such as *Medgaz* and *TransMed*. These pipelines provide a unique opportunity for hydrogen export with minimal additional infrastructure costs, enhancing Algeria's competitive edge in this emerging market.

Additionally, Algeria has recognized the importance of human capital and technology in facilitating the energy transition. The government has launched initiatives to foster scientific research and technological innovation in renewable energy and hydrogen sectors, often in collaboration with international partners. Moreover, the national roadmap for green hydrogen outlines strategies to attract investments and establish Algeria as a hub for clean energy development.

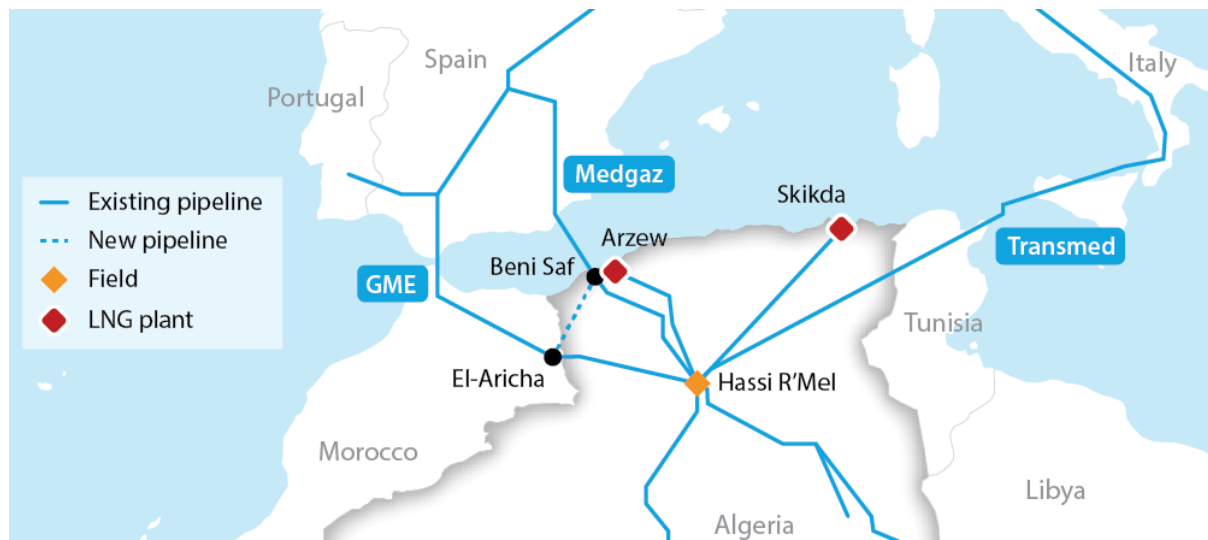

Figure 1-12 Algeria's strategic Mediterranean location and its gas pipelines to Europe [22]

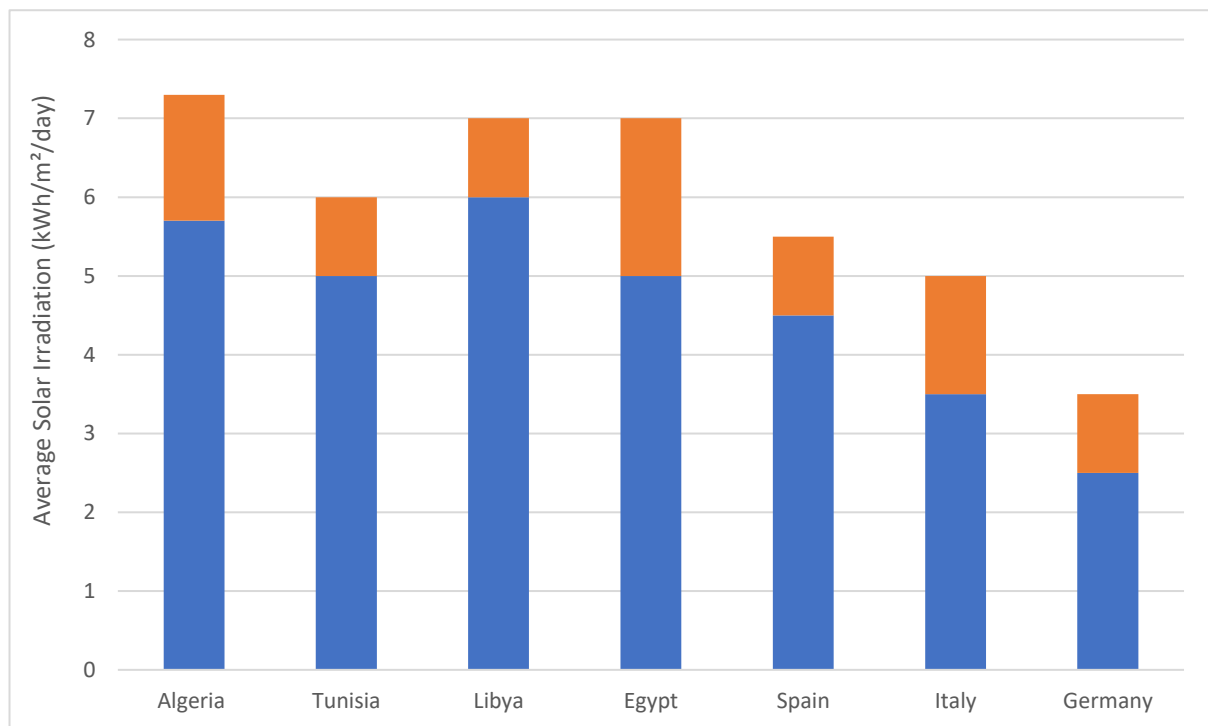

Figure 1-13 Comparing solar irradiation levels between Algeria and other regional countries [23]

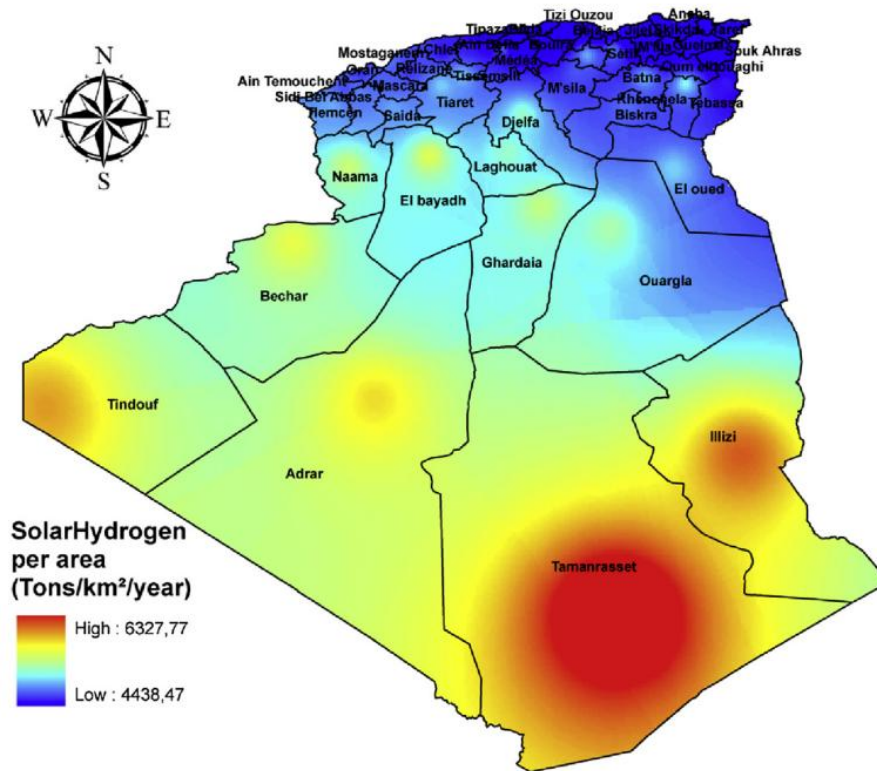

Figure 1-14 hydrogen production potential from solar energy [24]

1.4 Research Objectives and Significance

1.4.1 Research Objectives

The primary aim of this research is to explore and enhance the performance of renewable energy systems in Algeria, with a focus on green hydrogen production. Specifically, the research seeks to:

1. **Evaluate the Potential of Green Hydrogen in Algeria:** Analyse the country's solar energy resources and assess their suitability for large-scale green hydrogen production. This involves using advanced simulation tools like HOMER Pro to determine the productivity and efficiency of photovoltaic (PV) systems across different Algerian regions.
2. **Address Key Challenges in Green Hydrogen Production:** Investigate the major barriers to green hydrogen implementation in Algeria, including water resource management, energy storage, and infrastructure limitations. Propose sustainable solutions such as seawater electrolysis and wastewater utilization to mitigate these challenges.

3. **Enhance Photovoltaic System Efficiency:** Develop and test advanced PV system models integrated with electrolyzers to optimize hydrogen production. Implement maximum power point tracking (MPPT) techniques to improve the efficiency and reliability of PV systems in varying environmental conditions.
4. **Model and Improve Fuel Cell Performance:** Create sophisticated digital twin models of fuel cells using MATLAB Simscape to enhance operational monitoring and error detection. This objective aims to bridge the gap between theoretical simulations and real-world fuel cell performance, contributing to more efficient hydrogen utilization.
5. **Assess the Techno-Economic Feasibility of Green Hydrogen Projects:** Conduct a comprehensive techno-economic analysis to evaluate the viability of green hydrogen projects in Algeria, considering factors such as production costs, environmental impact, and export potential. Identify strategic opportunities for Algeria to become a regional leader in green hydrogen production and export to European markets.

1.4.2 Significance of the Research

This research holds substantial significance on multiple fronts, contributing to both academic knowledge and practical advancements in the field of renewable energy and hydrogen technologies:

1. **Contribution to Energy Sustainability:** By harnessing Algeria's abundant solar resources, this research supports the country's transition towards a sustainable energy future. It provides a roadmap for leveraging green hydrogen to reduce reliance on fossil fuels, thereby contributing to global decarbonization efforts and mitigating climate change impacts.
2. **Economic and Strategic Benefits for Algeria:** The findings of this research can help position Algeria as a key player in the emerging green hydrogen market. Exporting green hydrogen to Europe could generate significant economic revenue and foster technological advancements, promoting economic diversification and reducing dependency on hydrocarbons.
3. **Innovative Solutions for Water Management:** Addressing water scarcity challenges through innovative methods such as seawater electrolysis and wastewater recycling not only supports green hydrogen production but also contributes to sustainable water resource management, a critical issue in arid regions like Algeria.

4. **Technological Advancements:** The development of advanced PV and fuel cell models enhances the technical knowledge base, providing valuable insights into optimizing renewable energy systems. This research could serve as a foundation for future technological innovations and collaborations in the renewable energy sector.
5. **Global Relevance and Replicability:** While the research focuses on Algeria, its methodologies and findings can be applied to other regions with similar climatic and resource conditions. This contributes to the global body of knowledge on green hydrogen production and the integration of renewable energy systems.

In summary, this research not only addresses Algeria's specific energy challenges but also offers scalable solutions with broader applications, reinforcing the country's strategic importance in the global transition to sustainable energy.

1.5 Conclusion

This chapter has laid the groundwork for understanding the critical role of renewable energy and green hydrogen in addressing the global energy crisis. By examining the challenges posed by climate change, rising energy demand, and geopolitical instabilities, it underscores the urgency of transitioning to sustainable energy systems. Green hydrogen, as a clean and versatile energy carrier, emerges as a pivotal solution, offering significant potential to decarbonize key sectors and enhance global energy security.

The chapter also highlights Algeria's unique position in this transition, given its abundant solar resources, strategic location, and existing energy infrastructure. These factors provide the country with a competitive edge in contributing to the global shift toward green energy.

Building on this foundation, the subsequent chapters will delve deeper into the technical, economic, and strategic dimensions of green hydrogen development. They will explore the integration of renewable energy systems, the challenges of implementation, and the opportunities for Algeria to harness its full potential in the emerging green hydrogen economy

Chapter 2:
**Renewable Resources and
Energy Strategy in Algeria**

Chapter 2 Renewable Resources and Energy Strategy in Algeria

Algeria's transition to a green hydrogen-based economy hinges on its vast renewable energy resources, strategic geographical position, and its potential to become a major player in the global hydrogen market. This chapter delves into the country's renewable energy landscape, analysing its abundant solar and wind energy potential, water resources for hydrogen production, and existing infrastructure.

The chapter begins by reviewing global advancements in renewable energy technologies and their relevance to Algeria. It then highlights the country's unique geographical advantages, including its proximity to Europe and extensive natural gas infrastructure, which could be repurposed to facilitate hydrogen exports. Additionally, the chapter examines Algeria's national renewable energy strategy, outlining key projects, partnerships, and milestones aimed at achieving energy diversification and sustainability.

Moreover, the socio-economic benefits of green hydrogen development, such as job creation and economic diversification, are explored, emphasizing the transformative potential of renewable energy projects. The chapter concludes by addressing the challenges faced in resource utilization and integration while offering insights into Algeria's readiness to lead the green energy transition.

This comprehensive analysis underscores Algeria's strategic importance in the global push for decarbonization, positioning it as a pivotal contributor to the renewable energy revolution.

2.1 Literature Review:

2.1.1 Overview of Global Advances in Renewable Energy:

The transition to sustainable energy systems has garnered significant attention in recent years, particularly in the context of green hydrogen production and the optimization of renewable energy systems. This review explores ten notable research works, highlighting their objectives, methodologies, and findings, while identifying common themes and unique contributions to the field.

To begin with, **Bahri et al. (2022)** proposed a hybrid system combining photovoltaic (PV) and fuel cell (FC) technologies to meet the energy demand of a telecommunications tower in Wanoogha, utilizing HOMER software for optimization. Their study demonstrated that the

hybrid system achieved minimal total net present cost (TNPC) and levelized cost of energy (LCOE), with zero carbon emissions, establishing its viability for off-grid applications. [25]

Continuing on the theme of techno-economic feasibility, **Zghaibeh et al. (2022)** analyzed the potential of a 5 MW solar power plant in Salalah, Oman, for green hydrogen production. The results revealed an annual output of approximately 90,910 kg of hydrogen, with a cost-recovery timeline of eight years, showcasing the economic promise of solar-driven hydrogen systems in arid regions. [26]

Furthermore, **Renaudineau et al. (2021)** delved into the challenges and opportunities associated with coupling photovoltaic systems with electrolysis technologies. Their work emphasized the superior potential of proton exchange membrane (PEM) electrolyzers over alkaline systems, particularly when coupled with short-term energy storage, to enhance efficiency and stabilize power supply. [27]

Building on the integration of solar energy, **Tao et al. (2022)** explored three configurations for aligning PV systems with electrolyzers. Among these, the load-matching PV system emerged as the most efficient and scalable, offering a 30% reduction in initial costs compared to other configurations, thus underscoring the importance of design optimization. [28]

Turning to wind energy, **Xiao et al. (2020)** proposed a hydrogen-electricity storage system tailored for wind power integration. Their findings indicated that leveraging hydrogen sales as opposed to electricity sales yielded higher profitability, especially under conditions of low electricity prices. [29]

Similarly, **Abdulrahman S. Al-Buraiki et al. (2022)** investigated a hybrid solar-wind system for meeting residential energy and hydrogen demands in Dhahran, Saudi Arabia. The study highlighted the system's ability to generate surplus energy efficiently, which could be utilized for cost-effective hydrogen production. [30]

On the topic of operational efficiency, **Alejandro Ibáñez-Rioja et al. (2021)** introduced a novel methodology to optimize solar-powered electrolyzers using advanced control algorithms, such as particle swarm optimization (PSO). Their approach successfully reduced the cost of hydrogen production, emphasizing the critical role of algorithmic enhancements in renewable energy systems. [31]

Shifting focus to surplus energy utilization, **Al-Ghussain et al. (2022)** evaluated the use of excess renewable energy in Jordan for hydrogen production. Their analysis revealed that wind-based systems provided the lowest production costs, and hydrogen sales proved more profitable than electricity sales, highlighting a strategic opportunity for energy resource optimization. [32]

Meanwhile, **Ozturk et al. (2022)** explored the integration of hydrogen with natural gas in Zonguldak, Turkey. Their study demonstrated that blending 20% hydrogen into natural gas improved thermal efficiency while significantly reducing carbon dioxide emissions, suggesting a promising pathway for decarbonizing traditional energy systems. [33]

Lastly, **Karayel et al. (2021)** developed a hydrogen production map for Turkey based on solar energy potential. They identified Erzurum and Konya as prime locations, estimating a total production capacity of 415–427 million tons of hydrogen annually, thereby emphasizing regional resource assessment as a critical factor in strategic planning. [34]

Continuing the research efforts to explore global green hydrogen potentials, the study by **Ramachandra Bhandari et al. (2022)** examined Niger's capacity to produce green hydrogen to tackle challenges in transitioning to green energy. The study provided projections for hydrogen demand until 2040 and modeled the additional solar panel capacity required. Results demonstrated Niger's ability to produce a significant hydrogen surplus beyond its needs, leveraging technologies such as alkaline and advanced proton electrolysis. [35]

Another study by **Rafika Boudries et al. (2021)** highlights the potential of producing hydrogen using high-temperature electrolyzers supported by concentrated solar power systems. Through a techno-economic analysis, the results showed that improving solar panel efficiency and increasing electrolysis temperatures can significantly reduce production costs, achieving higher competitiveness compared to traditional systems. [36]

The field performance of a solar hydrogen system was assessed in Ouargla, Algeria by **A. Gougui et al.** where a mathematical model was developed to estimate productivity. Results revealed that direct strategies are more efficient and cost-effective, achieving an energy efficiency rate of 34.5% for the system. [37]

In Duqm, Oman, **Abdullah Al-Badri et al.** proposed a hybrid system combining solar, wind, and fuel cells for electricity and hydrogen production. Several scenarios were analyzed using HOMER Pro software, demonstrating significant advantages in reducing carbon emissions and achieving effective energy storage. [38]

The study by You Guo et al. explored an innovative model for a green methanol plant relying on hydrogen produced from renewable energy. The results showed that combining wind and solar energy reduces production costs and enhances stability, with the potential to compete with fossil fuels under high carbon tax policies. [39]

A hybrid system combining solar and wind energy to produce hydrogen through a highly efficient membrane reactor was proposed in another study of **Bingzheng Wang et al.** The results achieved an energy efficiency rate of 62.48%, with relatively low production costs, making it a sustainable and effective solution. [40]

In Egypt, the economic and environmental performance of a hybrid system using solar and wind energy for hydrogen production was evaluated by **Mohamed Nasser et al.** The results demonstrated good production efficiency while significantly reducing carbon emissions over the system's lifetime. [41]

Debarun Banerjee et al. focused on photo reforming technology using renewable biomass resources for hydrogen production. The research highlighted the importance of catalysts, such as TiO₂ and Au–Mn₃O₄, in improving production efficiency, noting that bio-oxygenate properties and operating conditions significantly impact production rates. [42]

F. Gutierrez-Martin proposed a methodology for a PV-H₂ hybrid system, comparing two configurations (with and without batteries) in Madrid and Fisciano. Results highlighted that directly connected PV-electrolyzer (PV-EL) systems can achieve high coupling factors without MPPT devices. While battery-assisted electrolysis reduces electrolyzer sizes, it increases energy and battery costs. The study demonstrated the potential for cost reductions in off-grid hydrogen production through optimized system integration. [43]

In Sweden, a study analysed data from the Mariestad refuelling station to evaluate cost components of hydrogen production using solar and wind energy. The results suggested that combining wind and solar PV reduces the levelized cost of hydrogen (LCOH) in off-grid

configurations. On-grid solutions also showed promise in reducing LCOH, with recommendations for exploring integration with hydropower in future research. [44]

Alexa Grimm et al. conducted an analysis comparing photoelectrochemical (PEC) systems with photovoltaic-electrolysis (PV-E) systems for hydrogen production. Findings indicated that PV-E systems have a lower LCOH (\$6.22/kg H₂) compared to PEC systems (\$8.43/kg H₂), underscoring the limited commercial potential of PEC technology despite ongoing research interest. [45]

Ying Zhou's article examined the global energy revolution and proposed strategies to advance green hydrogen technologies. Recommendations included enhancing competitiveness, integrating low-carbon needs across sectors, and fostering regional trials to establish a robust hydrogen industry chain. The article emphasized green hydrogen's role in addressing climate change through coordinated efforts. [46]

Mohamad Ramadan introduced the "Green to Green" (G2G) label for systems combining renewable energy sources and green storage technologies. The study reviewed solar-hydrogen coupling configurations, such as parabolic trough-hydrogen and photovoltaic-hydrogen systems, noting their effectiveness in applications like fuel cell vehicles. [47]

M. A. Khan's research reported a concentrator photovoltaic electrolysis (CPV-E) system achieving a solar-to-hydrogen (STH) efficiency of 28% at 41 suns. The findings suggested that optimizing CPV cells and alkaline electrolyzers could make CPV-E a commercially viable solution for hydrogen production. [48]

Jonathon Yates et al. employed a Monte Carlo method to identify cost drivers and conditions for competitive stand-alone PV-powered hydrogen electrolysis systems. The study emphasized the importance of localized factors in achieving economic feasibility. [49]

Diego Concha's study compared DCX topologies for PV-to-H₂ applications, identifying the half-bridge center-tapped LLC DCX as the most efficient for the system. Future work aims to optimize pre-regulation stages and validate system performance experimentally. [50]

Khalifa Aliyu Ibrahim described a solar green hydrogen production system using concentrated photovoltaics (CPV) and multijunction solar cells. The design significantly

improved green hydrogen production efficiency through enhanced energy capture and conversion. [51]

Harshal V. Patel detailed the design and simulation of a green hydrogen production system, incorporating a solar PV emulator and energy storage. The MATLAB-based study provided insights for sustainable system selection and implementation. [52]

Taís Bisognin Garlet et al. highlighted Brazil's renewable energy potential, low production costs, and international competitiveness. Despite these advantages, challenges such as weak legal frameworks and insufficient government initiatives were noted. The analysis offered valuable insights for advancing Brazil's green hydrogen market. [53]

Qusay Hassan et al. examined the potential of green hydrogen production in Saudi Arabia, focusing on global trends, the nation's energy mix, relevant policies, and readiness for integrating hydrogen into the energy framework. The findings indicate Saudi Arabia's significant potential in this area, driven by its extensive energy infrastructure and ongoing renewable energy initiatives. However, the study also identifies challenges, including underdeveloped infrastructure, economic feasibility concerns, and uncertainties in market demand and technological readiness. The authors highlight the need for policy reforms to address these barriers, emphasizing Saudi Arabia's potential to leverage green hydrogen for economic diversification and energy sustainability. [54].

In another study, **Qusay Hassan et al.** provided a regional analysis of renewable energy potential across 27 EU countries and the UK. Germany, Northern Sweden, and France emerge as leaders in renewable electricity generation and green hydrogen development. Despite its comprehensive scope, the study notes limitations due to regional bias and dependency on current data. The findings serve as a vital resource for understanding Europe's capacity to integrate green hydrogen into its energy portfolio. [55]

V.A. Panchenko et al. analyzed global advancements in green hydrogen production, focusing on regions with high renewable energy potential [56]. The study outlines key parameters for competitive hydrogen production, including efficiency (65%), fixed operating costs (3% of capital), and a plant lifetime of 20 years. While green hydrogen promises to reduce emissions and enable renewable-rich regions to become exporters, the study highlights significant challenges such as high initial costs, material limitations, and regulatory issues. The authors

stress that, despite the infancy of current projects, advancements in technology and cost efficiency could make green hydrogen a cornerstone of the global energy transition.

Hongjing He et al. evaluated the feasibility of green hydrogen production through seawater electrolysis on remote Japanese islands. Utilizing solar, wind, and battery systems, the authors compare scenarios based on costs and CO₂ emissions [57]. Notably, the inclusion of chemical product earnings (Case 3) achieved a 16.6% reduction in costs and a 13.2% decrease in emissions compared to the baseline case. The study highlights the dual environmental and economic benefits of this approach, although challenges such as high initial investments and reliance on intermittent renewable energy sources persist.

Emigdio Chavez-Angel et al. focused on the Atacama Desert, evaluating the practical challenges of green hydrogen production using a mobile pilot plant (P3H2V), particularly for the mining sector [58]. Daily hydrogen production ranged from 2.0 to 2.5 kg, with a theoretical maximum of 2.8 kg/day. Efficiency was hindered by photovoltaic panel soiling and extreme temperatures. Despite these limitations, the study demonstrates the feasibility of green hydrogen production under realistic field conditions and underscores the importance of optimizing operational factors to enhance efficiency in arid regions.

D. Franzmann et al. provided a comprehensive cost analysis of green hydrogen production and export in 28 countries, focusing on solar-rich regions and onshore wind potentials until 2050. It highlights hydrogen production potentials exceeding 1500 PWhLHV annually at costs below 2.3 EUR/kg. While decentralized photovoltaic production emerges as a cost-effective solution, export costs from democratic regions are 7% higher, posing challenges for global trade. The authors emphasize the critical role of solar energy and seawater desalination in establishing sustainable hydrogen supply chains. [59]

G. Kubilay Karayel et al. examined Canada's green hydrogen potential through a detailed analysis of solar energy across provinces and various electrolysis technologies. Quebec and Ontario emerged as leaders, contributing to a total potential of 205–211 Mt annually. Decentralized photovoltaic systems were identified as effective for urban areas, although solar intensity and cloud cover remain limiting factors. The findings underscore the importance of strategic planning and regional optimization to align Canada's green hydrogen initiatives with its solar resources. [60]

Robert William Makepeace et al. explored the economic viability of green hydrogen transportation through various carriers, such as ammonia and compressed hydrogen. Using Monte Carlo simulations, the study identifies the USA and Australia as cost leaders due to inexpensive renewable electricity. The authors highlight the importance of carbon pricing in enhancing green hydrogen's competitiveness. While offering robust insights into future cost trends, the study acknowledges that its complex models may limit applicability across diverse regions. [61]

2.1.2 Analysis and Commentary on the Reviewed Works:

A. Scientific Value of the Reviewed Studies

The reviewed studies collectively highlight significant advancements in green hydrogen production, focusing on optimizing renewable energy systems, integrating advanced electrolysis technologies, and evaluating economic aspects. Their value lies in offering comprehensive insights into challenges and potential solutions, particularly in efficiency, planning, and integration with existing systems.

For instance, studies conducted in Oman and Turkey demonstrate the potential to balance economic feasibility with environmental sustainability. Research on surplus energy utilization in Jordan reveals strategic methods to maximize resource use, while techno-economic modeling underscores how improving efficiency and rethinking hydrogen transport and storage can reduce costs and enhance viability.

B. Lessons Learned

The body of work provides several strategic insights crucial for advancing the green hydrogen sector:

1. **Grid Integration and Hybrid Energy Systems:** The studies underscore the role of hydrogen in enhancing grid flexibility through energy storage and future utilization. Hybrid energy systems, combining solar and wind, as highlighted in the Dhahran study, demonstrate increased energy efficiency and minimized losses. These models are particularly effective in regions experiencing weather variability and intermittent energy supplies.
2. **Regional Resource Evaluation:** Precise geographic analysis of renewable energy distribution is a cornerstone of effective planning. Hydrogen production maps, such as

the one developed in Turkey, provide valuable tools for identifying optimal project locations. Algeria, with its vast Sahara region, could leverage similar analyses to pinpoint high-potential sites for large-scale hydrogen production.

3. **Economic Modeling:** The importance of cost reduction through advanced economic modeling is evident. For instance, Oman's study, which projected a cost recovery period of only eight years, demonstrates the value of integrating efficiency improvements and selecting suitable sites. Algeria can adopt similar methodologies to enhance the economic competitiveness of its green hydrogen initiatives.
4. **Efficiency Optimization:** Innovations such as high-efficiency photovoltaic systems (CPVs) and high-temperature electrolysis show promise in boosting hydrogen production rates while minimizing costs. These studies highlight a balance between cost and performance, providing sustainable long-term solutions.
5. **Global Market Insights:** Case studies from leading nations like Germany and Turkey highlight the importance of flexible regulatory frameworks, private investment encouragement, and research collaborations. Additionally, the emphasis on exporting hydrogen to major markets like Europe illustrates the potential for maximizing local resources.
6. **Emerging Technologies and Innovations:** The integration of emerging technologies, such as AI for data analysis and operational optimization, presents significant opportunities. Algeria could utilize these tools to enhance performance, leveraging real-time weather and energy data for precise forecasting and improved system management.

C. How Algeria Can Benefit

The reviewed studies offer Algeria valuable insights into advancing its green hydrogen sector. With its abundant solar and wind resources, Algeria is well-positioned to become a global leader in green hydrogen production. These works provide a roadmap for Algeria to prioritize and refine its strategic plans. By leveraging knowledge in system design, electrolysis technologies, and green hydrogen modelling, Algeria can enhance production efficiency and achieve significant economic and environmental benefits.

Moreover, understanding lessons from international experiences allows Algeria to devise strategies that capitalize on its competitive advantages while avoiding challenges encountered by others. Fostering research collaboration and developing supportive regulatory frameworks

will further enable Algeria to smoothly transition to utilizing green hydrogen across various industries, bolstering its international competitiveness.

D. Challenges and Future Outlook

While the studies present promising directions, they also highlight key challenges, including high initial costs, regulatory hurdles, and infrastructure limitations. Algeria must invest in research and development, establish favorable legislative environments, and focus on adopting advanced electrolyser models that ensure higher efficiency and reduced costs.

2.2 Analysis of Renewable Energy Resources in Algeria

2.2.1 Solar Energy

Algeria is uniquely positioned as one of the world's most promising locations for solar energy exploitation, owing to its exceptional solar irradiance levels. The country's annual solar potential is estimated to exceed 169,440 TWh, with direct normal irradiance (DNI) ranging between 5 and 7 kWh/m²/day, particularly in the vast expanses of the Sahara Desert. This natural endowment positions Algeria as a prime candidate for the deployment of large-scale photovoltaic (PV) and concentrated solar power (CSP) systems, essential for driving green hydrogen production. [24]

More than 80% of Algeria's landmass lies within the Sahara, a region characterized by some of the highest solar irradiation levels globally, varying between 2,000 and 3,900 kWh/m² annually. Such conditions make the country ideal for year-round energy generation from solar technologies. Reflecting this potential, Algeria's renewable energy roadmap has set an ambitious target: the installation of 22 GW of renewable energy capacity by 2035, with solar power as the centerpiece of this strategy. [62]

Currently, operational solar plants in Algeria contribute over 450 MW to the energy mix, with significant expansions underway. Projects like the 200 MW solar power plant in Laghouat demonstrate the country's commitment to leveraging its renewable resources. These initiatives not only enhance Algeria's energy independence but also lay the groundwork for integrating green hydrogen production into its energy strategy, reinforcing its role in global energy transitions.

By harnessing its vast solar resources, Algeria is poised to become a leader in sustainable energy and a key supplier of green hydrogen to international markets, particularly Europe.

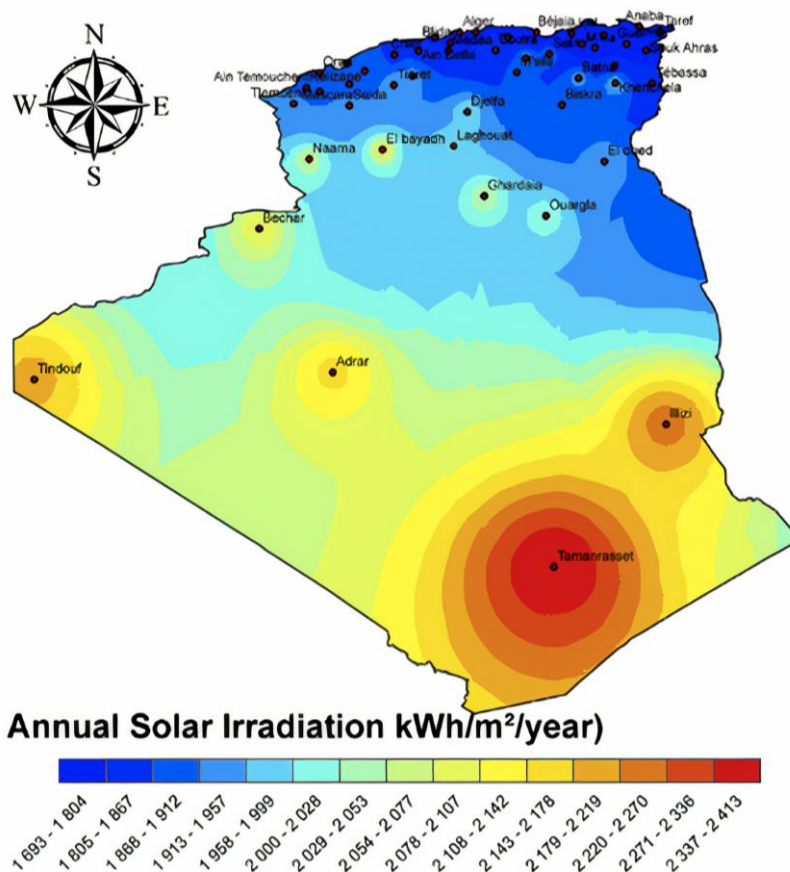

Figure 2-1 Solar Irradiance Map of Algeria [24]

2.2.2 Wind Energy

Algeria’s wind energy potential, though less prominent than its solar capabilities, represents a significant opportunity for diversifying its renewable energy portfolio. Wind energy resources are concentrated in the southern regions and along the northern coastal areas, where average wind speeds range between 6 and 11 m/s at a height of 50 meters above ground level. These wind conditions are highly suitable for efficient power generation, making wind energy a promising complement to solar energy in the production of green hydrogen. [24]

Recent assessments place Algeria's exploitable wind energy capacity at over 35 GW, highlighting its untapped potential. This resource could play a critical role in hybrid renewable energy systems, where wind and solar technologies combine to provide a stable and continuous energy supply. In particular, coastal and highland regions, with wind speeds reaching 5–8 m/s at a height of 10 meters, offer feasible sites for wind power development.

Despite this promising potential, Algeria’s installed wind power capacity remains modest, currently around 10 MW as of 2024. This underscores the need for strategic investment and

development to capitalize on the resource. Developing large-scale wind projects in regions with optimal conditions could significantly enhance Algeria’s energy mix, reduce its reliance on fossil fuels, and strengthen its position as a producer of clean hydrogen for domestic and export markets.

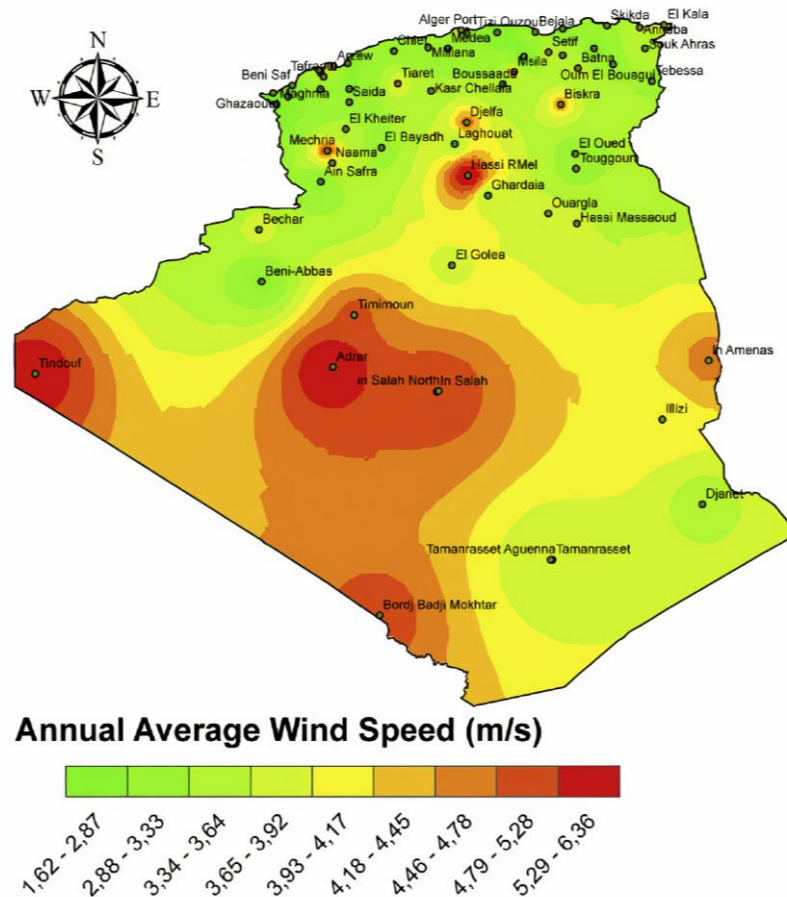

Figure 2-2 Annual Wind Speed Distribution in Algeria [24]

By integrating wind energy into its renewable energy strategy, Algeria can move closer to achieving energy security and sustainability while addressing global demands for green energy solutions.

2.2.3 Water Resources

Algeria possesses significant water resources that complement its renewable energy potential, enabling the production of green hydrogen on a large scale through international partnerships. Covering an expansive area of 2.4 million km², Algeria is the largest country in North Africa. Although 87% of its territory lies in arid desert regions with minimal rainfall, Algeria benefits from substantial fossil groundwater reserves. The northern regions, characterized by a Mediterranean climate, house both surface and renewable underground water sources. [63]

The Tell region, which constitutes only 7% of Algeria's land area, accounts for an impressive 90% of the country's surface water reserves. Conversely, the vast southern Sahara relies predominantly on fossil groundwater with limited natural replenishment. Algeria's water reserves are concentrated in six principal aquifers, most notably the Terminal Complex (CT) and the Continental Interlayer (CI). These confined aquifer systems form part of the transboundary Septentrional Saharan Aquifer System (SSAS), shared with Libya and Tunisia.

Annual rainfall in Algeria is estimated at approximately 100 billion m³, but 80% is lost to evaporation. The country's total usable water resources are calculated at 19.1 billion m³ annually, comprising 12.4 billion m³ from surface sources and 6.7 billion m³ from underground reserves. Despite this potential, only 6 billion m³ are effectively utilized via dam reservoirs, with around 4 billion m³ currently tapped across 110 operational dams. In the Sahara, groundwater reserves are estimated at 5.1 billion m³, of which 1.6 billion m³ are exploited at about 80% capacity, primarily through wells and boreholes. [63]

These water resources, particularly in the Sahara, are crucial for hydrogen production, especially when paired with desalination technologies or innovative water management strategies. This capability reinforces Algeria's potential as a hub for renewable hydrogen production, aligning its water resources with its broader energy transition goals.

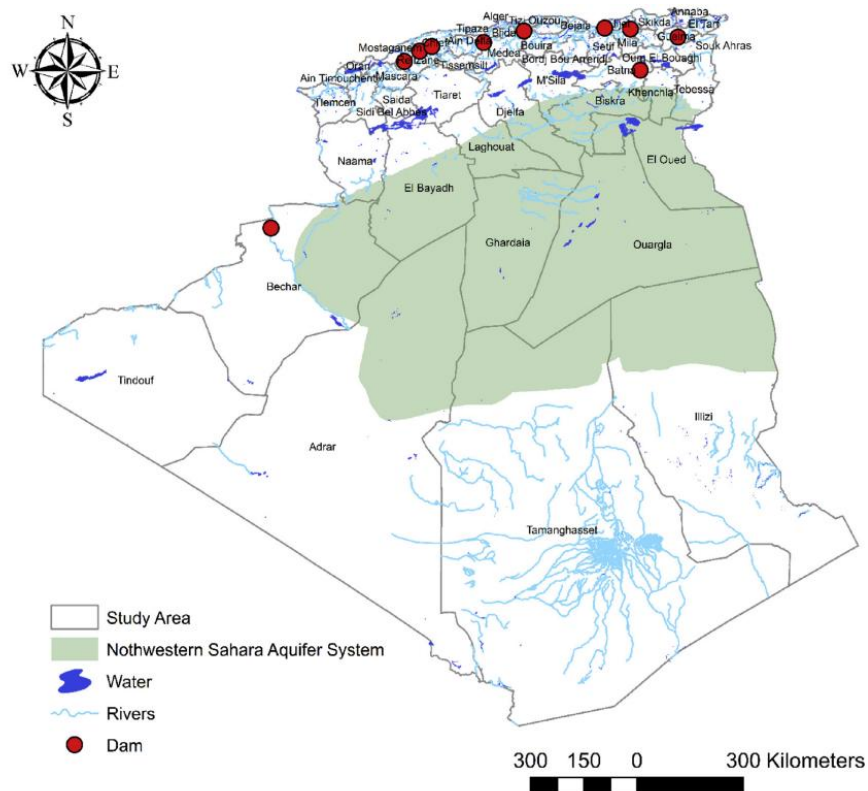

Figure 2-3 Algeria's Water Resources Overview [63]

2.3 Strategic Analysis of Algeria’s Geographical Location

Algeria’s geographical position as a gateway between Africa and Europe positions it as a promising global hub for green hydrogen production and export. Proximity to Europe—less than 200 kilometers across the Mediterranean Sea offers logistical advantages that minimize transportation costs for hydrogen and its derivatives.

Existing infrastructure, including the Trans-Mediterranean Pipeline (TransMed) to Italy and the Maghreb-Europe Gas Pipeline (MEG) to Spain, can be repurposed for hydrogen and ammonia transport. This repurposing reduces capital expenditure for new infrastructure, enhancing Algeria’s competitiveness in meeting Europe’s green hydrogen demands.

The European Union’s Green Deal targets net-zero emissions by 2050, emphasizing green hydrogen. Algeria’s established energy infrastructure, renewable energy initiatives, and geographical proximity position it as a key supplier for Europe’s decarbonization strategy. [64]

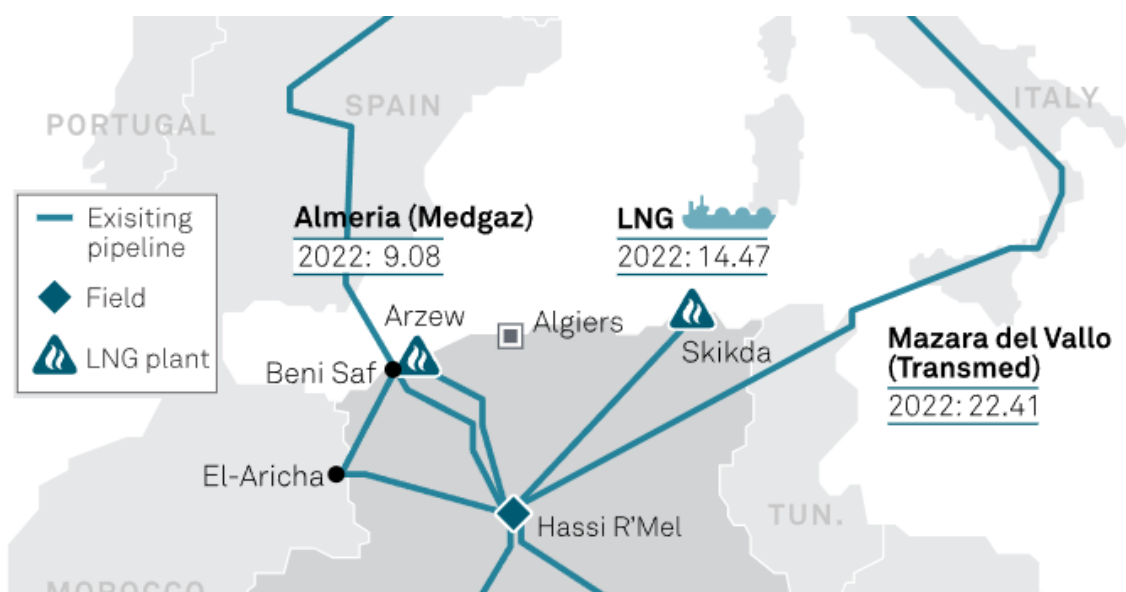

Figure 2-4 Algeria’s Energy Export Infrastructure

2.4 National Renewable Energy Strategy

2.4.1 Renewable Energy Strategy and Policies

Algeria’s National Renewable Energy and Energy Efficiency Program (NREAP) is central to its energy transition strategy, targeting 22,000 MW of renewable energy capacity by 2030. This includes 12,000 MW for domestic consumption and 10,000 MW for export, with a primary focus on solar energy.

The program's phases are as follows:

1. **Pilot and Testing (2011–2013):** Developed technical expertise, installing 110 MW of renewable capacity.
2. **Deployment Initiation (2014–2015):** Scaled efforts with an additional 650 MW of capacity.
3. **Large-scale Deployment (2016–2030):** Achieved 2,600 MW by 2020, with acceleration planned to meet the 2030 target.

To attract investments, Algeria offers tax incentives, feed-in tariffs, and regulatory measures, complemented by technology transfer agreements with the EU. Initiatives like the "Solar 1,000" project aim to develop significant PV capacities, enhancing Algeria's renewable energy leadership.

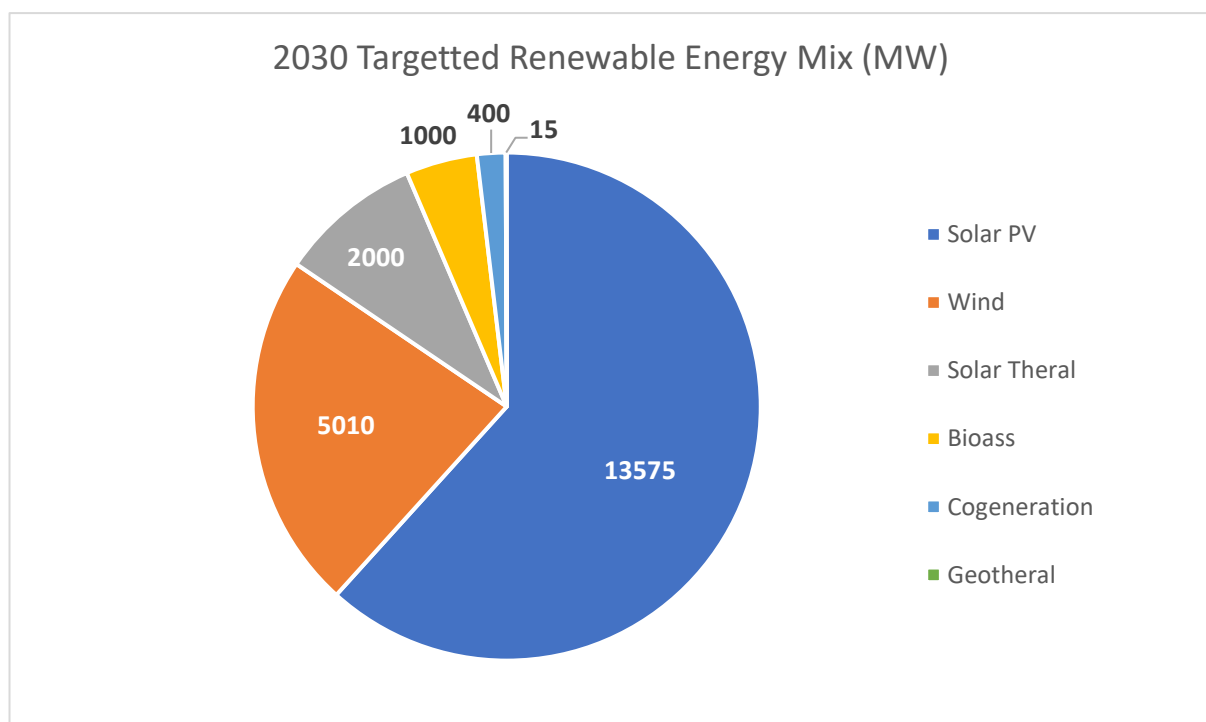

Figure 2-5 Progress of Algeria's Renewable Energy Goals (2020–2030) [65]

Policy and Strategy Development

To further its green hydrogen ambitions, Algeria has allocated \$20–\$25 billion for hydrogen-related projects by 2040. This includes establishing a hydrogen roadmap, investing in research and development, and forming international alliances. The strategy emphasizes utilizing Algeria's abundant renewable resources to create a sustainable energy ecosystem.

2.4.2 Current Partnerships and Projects

Several international partnerships underscore Algeria’s commitment to green hydrogen. Collaborative efforts with Germany include the Algeria-Germany Hydrogen Partnership, which focuses on technology transfer and infrastructure development. Additionally, initiatives with Eni and Sonatrach aim to integrate renewable energy with hydrogen production. The MediGas and Galci projects explore the feasibility of adapting gas pipelines for hydrogen transport, further solidifying Algeria’s position as a regional leader in hydrogen. [66]

Table 2-1 Content of the Renewable Energy Development Program [66]

Unité : MW	1ère phase 2015-2020	2ème phase 2021-2030	TOTAL
Photovoltaïque	3 000	10 575	13 575
Eolien	1 010	4 000	5 010
CSP	-	2000	2 000
Cogénération	150	250	400
Biomasse	360	640	1 000
Géothermie	05	10	15
TOTAL	4 525	17 475	22 000

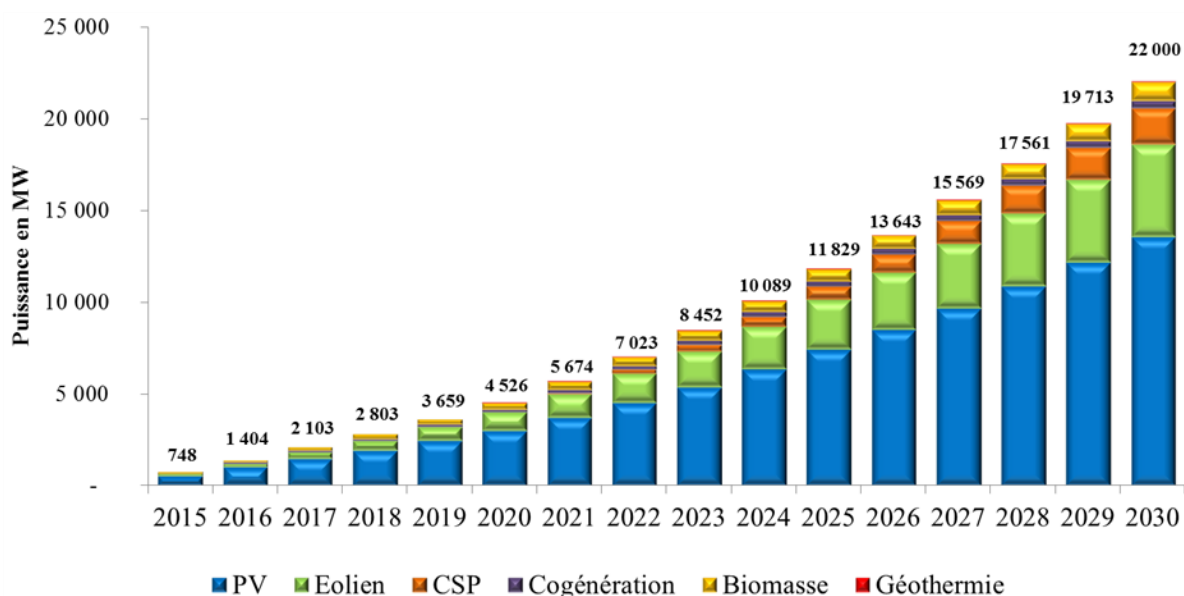

Figure 2-6 the Renewable Energy Development Program (2015-2030) [66]

2.5 Export Potential to European Markets

Algeria’s strategic geographical position, adjacent to Europe and less than 200 kilometers across the Mediterranean Sea, gives it a logistical edge for exporting green hydrogen. Europe, seeking to meet its REPowerEU targets of importing 10 million tonnes of green hydrogen by 2030, views North Africa as a prime supplier. Algeria’s extensive natural gas pipeline network, connecting it to countries like Spain and Italy, could be repurposed for hydrogen transport, significantly reducing infrastructure costs.

In addition to its logistical advantages, Algeria’s competitive hydrogen production costs, under 2 \$ (270 DA) per kilogram compared to Europe’s 4\$ – 6\$ (540 – 810 DA) per kilogram, make it an attractive partner for the EU’s green energy transition. Existing pipelines, such as TransMed and MEG, can transport hydrogen blends of up to 20%, with adaptations for pure hydrogen transport planned by 2030.

Algeria’s LNG export terminals and energy-export expertise further support the transportation of green hydrogen and its derivatives, such as ammonia. Strategic partnerships with European energy firms, including ENI and Naturgy, align with EU priorities for North African hydrogen imports, solidifying Algeria’s position as a cornerstone of Europe’s decarbonization strategy.

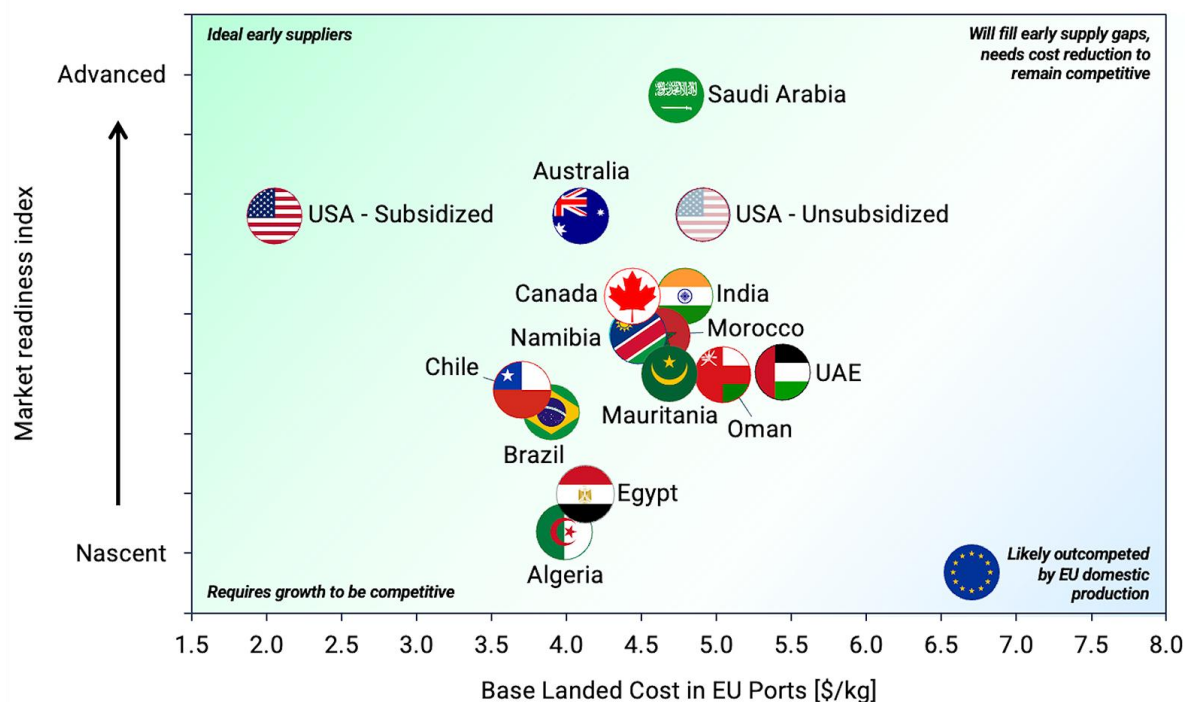

Figure 2-7 Green hydrogen exports targeting EU markets in 2030 [67]

Projections indicate that by 2050, up to 25% of Europe's hydrogen supply could involve imports from North Africa, with Algeria playing a key role. Leveraging its existing ports and infrastructure, along with its high solar irradiance levels exceeding 2,500 kWh/m² annually in southern desert regions, Algeria is well-positioned to meet Europe's growing hydrogen demand. By addressing challenges such as scaling up renewable energy projects, optimizing hydrogen storage, and adhering to EU green certification standards, Algeria is poised to establish itself as a leader in the global hydrogen economy.

2.6 Socio-Economic Benefits

Green hydrogen development can significantly boost Algeria's socio-economic landscape. For every dollar invested in renewable energy and hydrogen, global trends indicate a return of \$1.5 to \$5, according to the International Renewable Energy Agency (IRENA). Algeria could benefit from job creation in various sectors, including renewable energy infrastructure, electrolyser manufacturing, and hydrogen transport logistics. Additionally, these projects could reduce unemployment, which was estimated at 12.7% in Algeria in 2022, and diversify the country's economy, decreasing its reliance on hydrocarbons.

2.7 Current Challenges

Despite its immense renewable energy potential, Algeria faces several significant challenges in realizing its green energy ambitions.

High initial investment costs for infrastructure, such as large-scale solar plants and green hydrogen production facilities, remain a major obstacle. For instance, the capital cost of electrolysers ranges from 500 \$ (67500 DA) to 1,000 \$ (135000 DA) per kW, with additional expenses for integrating renewable energy sources and storage solutions. [68]

Limited technological expertise and dependence on imported equipment further hinder progress. Algeria has been taking steps to address this by collaborating with international entities for technology transfer and by launching training programs to build a skilled workforce capable of managing and maintaining renewable energy systems. [69]

Infrastructure gaps present another bottleneck, particularly for connecting remote renewable energy projects in the Sahara to urban centers and export markets. Significant investments are

required to expand the grid infrastructure and implement energy storage solutions to balance intermittent renewable energy supply.

Water scarcity, a pressing issue in a predominantly arid country, poses a challenge for green hydrogen production, which traditionally relies on purified water for electrolysis. Algeria receives an average annual rainfall of less than 250 mm in most regions, which limits freshwater availability. To address this, innovative solutions such as **seawater electrolysis** and **wastewater recycling** are being explored. These methods can significantly reduce freshwater dependency while maintaining sustainable production. [69]

Algeria’s **proximity to Europe** offers substantial export opportunities for green hydrogen, given the EU’s goal of importing 10 million tons of green hydrogen annually by 2030. Existing natural gas pipelines, like the Medgaz pipeline, could be repurposed to transport hydrogen, potentially reducing costs by up to 60% compared to building new infrastructure. These developments position Algeria as a strategic partner for Europe's green energy transition. [69]

Table 2-2 Challenges and Proposed Solutions for Algeria’s Renewable Energy Sector

Challenge	Description	Proposed Solutions
High Initial Investments	Capital costs for infrastructure like solar plants and electrolyzers range from \$500 to \$1,000 per kW.	Encourage foreign investments, public-private partnerships, and government subsidies for initial costs.
Technological Dependence	Reliance on imported equipment and limited local expertise.	Develop technology transfer agreements, launch workforce training programs, and promote local innovation.
Infrastructure Gaps	Remote renewable projects require connection to urban centers and export markets; grid expansions needed.	Invest in grid expansion, implement energy storage systems, and repurpose existing infrastructure.
Water Scarcity	Freshwater availability is low due to Algeria’s arid climate; electrolysis requires significant water use.	Innovate with seawater electrolysis, wastewater recycling, and desalination technologies.

Regulatory Challenges	Policies and frameworks are not streamlined, discouraging investment.	Simplify regulations, establish clear renewable energy incentives, and foster public-private partnerships.
Export Opportunities	Potential for green hydrogen export but requires cost-effective transport solutions.	Leverage existing pipelines (e.g., Medgaz) to transport hydrogen, reducing costs by up to 60%.

2.8 Conclusion

This chapter has provided a detailed exploration of Algeria’s renewable energy resources, its strategic geographical advantages, and the national strategies shaping its transition to a green hydrogen economy. With its vast solar and wind energy potential, Algeria is uniquely positioned to lead the renewable energy revolution, particularly in North Africa. The analysis also highlighted the critical role of water resource management and existing infrastructure in enabling large-scale hydrogen production and export, particularly to Europe.

The socio-economic benefits of green hydrogen development are equally significant, offering opportunities for job creation, economic diversification, and technological advancement. These benefits underscore the transformative impact of investing in renewable energy, not only for Algeria’s energy sector but also for its broader economic landscape.

While challenges such as infrastructure modernization, resource optimization, and policy implementation remain, they also present opportunities for innovation and collaboration. Addressing these challenges will be pivotal in ensuring Algeria’s readiness to meet the growing global demand for green hydrogen.

Building on this foundation, the subsequent chapters will delve into the technological systems, advanced methodologies, and integrated strategies required to overcome these challenges and unlock Algeria’s full potential as a global leader in sustainable energy. This journey reflects Algeria’s commitment to shaping a cleaner, more resilient energy future.

Chapter 3:
**Advanced Systems for Green
Hydrogen Production**

Chapter 3 Advanced Systems for Green Hydrogen Production

Green hydrogen production relies on sophisticated technologies and integrated systems that optimize the conversion of renewable energy into a clean fuel. The chapter begins by exploring photovoltaic (PV) systems as a key driver for water electrolysis, detailing the challenges and innovative design strategies that enhance efficiency and scalability. It then reviews various electrolysis methods alongside emerging solutions for sustainable water sourcing, highlighting their role in large-scale hydrogen production.

Advanced modelling techniques, including digital twins and simulation frameworks, are introduced to bridge the gap between theoretical performance and real-world applications. Finally, the integration of storage systems with photovoltaic grids is examined as a critical factor in mitigating the intermittency of renewable sources and ensuring stable energy supply.

Overall, the chapter lays a concise yet comprehensive foundation for the advanced technical strategies that underpin efficient, scalable, and economically viable green hydrogen production systems.

3.1 Hydrogen Production Using Photovoltaic (PV) Energy

Photovoltaic (PV) systems have emerged as a fundamental technology in the pursuit of sustainable green hydrogen production. These systems leverage abundant solar resources to generate electricity, which is subsequently used to power water electrolysis. However, integrating PV energy into hydrogen production presents unique technical challenges, necessitating innovations in system design and control. This section explores the potential of PV-driven hydrogen production, detailing system requirements, challenges, and innovations, with insights drawn from advanced modelling studies.

3.1.1 Overview of PV-Driven Hydrogen Production

The integration of PV energy into hydrogen production systems offers a carbon-free solution to the energy crisis. Through water electrolysis, electricity generated by PV panels is used to split water molecules into hydrogen and oxygen, with hydrogen serving as a clean energy carrier.

A key advantage of PV-driven hydrogen production lies in its scalability and adaptability to diverse geographical regions with abundant sunlight. In Algeria, with its high solar irradiation levels (2,000–3,000 kWh/m²/year), the potential for deploying PV systems to power hydrogen production is immense. Such systems can provide a renewable alternative to fossil-fuel-based hydrogen production, contributing to global decarbonization goals.

3.1.2 Challenges in PV Systems for Hydrogen Production

Despite its promise, PV-driven hydrogen production faces several challenges that impact efficiency and reliability:

- **Intermittency and Environmental Sensitivities:** Solar energy output is inherently variable, fluctuating with changes in weather, irradiance, and temperature. For example, efficiency drops significantly during periods of low sunlight or extreme heat, requiring robust system designs to mitigate these effects. [70]
- **Energy Conversion Efficiency:** Typical PV panels have efficiency ranges of 15–22%, and even under optimal conditions, a significant portion of solar energy is lost. This inefficiency directly influences the amount of electricity available for hydrogen production. [70]
- **Coupling with Electrolysis:** Integrating PV systems with electrolyzers requires precise synchronization to ensure stable hydrogen production. Variations in PV output can lead to suboptimal operation of the electrolyzer, resulting in energy losses and reduced hydrogen yield. [70]

3.1.3 Innovations in PV System Design

Innovations in system design are crucial to overcoming these challenges and maximizing the efficiency of PV-driven hydrogen production. Advanced modelling and control strategies play a pivotal role:

- **Implementation of Maximum Power Point Tracking (MPPT):** The study employs the Perturbation and Observation (P&O) MPPT technique, a widely used algorithm designed to optimize energy extraction from PV panels. By continuously adjusting the duty cycle, the system identifies and operates at the maximum power point, even under changing environmental conditions.
- **Use of DC-DC Boost Converters:** These converters stabilize the fluctuating voltage output from PV panels, ensuring a steady power supply to the electrolyzer. This not

only enhances the efficiency of hydrogen production but also prolongs the lifespan of system components.

- **Integration with Advanced Electrolysis Models:** The proposed PV system integrates seamlessly with advanced electrolyzer models developed using MATLAB Simulink. This combination enables real-time adjustments to power input, optimizing hydrogen production rates while minimizing energy losses.

3.1.3.1 Description of The Proposed System

Figure 3-1 depicts a comprehensive modelling process of the photovoltaic system that comprises three core components, each critically influencing the overall functionality and performance. At the foundation is the photovoltaic (PV) array, a network of interconnected solar cells meticulously designed to convert sunlight into electrical energy with high efficiency. Adjacent to this, the boost converter plays an essential role in voltage regulation by elevating the produced direct current (DC) to levels that support effective power transmission and utilization. Concurrently, the controller system armed with advanced algorithms and robust feedback mechanisms manages the dynamic interaction between the PV array and the boost converter, adjusting operational parameters in real time to maximize energy conversion efficiency while accommodating varying environmental conditions. This integrated modelling approach not only deepens the understanding of each component's individual characteristics but also facilitates a detailed analysis of their collective behavior, thereby enabling informed decision-making and the continuous optimization of photovoltaic system designs for improved performance and sustainability.

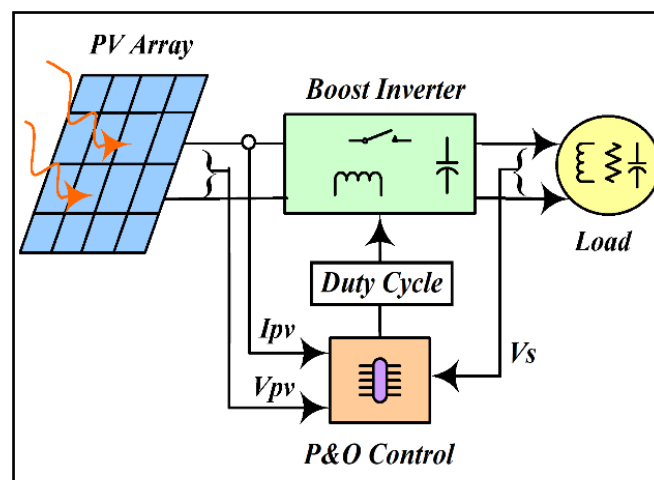

Figure 3-1 The Used System

Photovoltaic (PV) electrolyzers convert solar energy typically harnessed from photovoltaic panels into electrical energy that drives the electrolysis process, splitting water molecules into hydrogen and oxygen gases. These gases, serving as clean energy carriers, find application across various sectors. Current technologies encompass systems such as Proton Exchange Membrane (PEM), Alkaline, Solid Oxide (SOE), and Flow electrolyzers, each distinguished by differences in operating temperature, efficiency, and scalability. Some systems are integrated with energy storage solutions to ensure continuous hydrogen production, while hybrid systems combine multiple renewable sources to boost overall efficiency. Consequently, PV electrolyzers are pivotal to a sustainable energy future, with ongoing research dedicated to enhancing efficiency, reducing costs, and broadening their applications.

At the core of the electrolyzer's design are two half-cells, separated by a thin, insulating, yet proton-conducting Proton Exchange Membrane (PEM) located at the cell's center. On each side of this membrane is a porous catalyst layer where the essential electrochemical reactions occur. Together, the PEM and the catalyst layers form the Membrane Electrode Assembly (MEA). Surrounding the MEA, a current collector establishes both physical and electrical connections between the catalyst layer and the bipolar plate. The bipolar plate then functions as a critical structural component that not only maintains the cell's integrity and facilitates the movement of reactants and products but also isolates individual cells within a stacked configuration.

The electrolyzer undergoes multiple reactions, including anodic, cathodic, and overall processes, which are detailed as follows:

Anodic reaction:

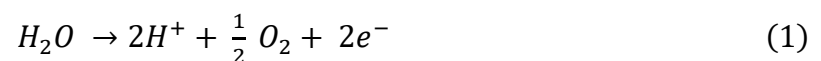

Cathodic reaction:



Global reaction:



3.1.3.2 Modelling of the photovoltaic panel

An ideal solar cell is typically modeled as a current source connected in parallel with a diode. However, real-world solar cells exhibit imperfections that necessitate the inclusion of additional components in the model. As depicted in **Figure 3-2**, two resistors one in series and another in parallel are introduced to effectively account for these non-ideal characteristics.

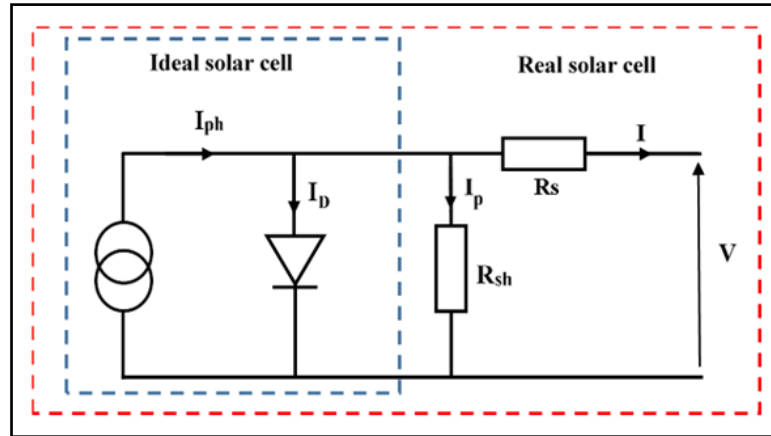

Figure 3-2 Electric model of solar cell

When the surface of a solar cell is illuminated, it activates the cell's inherent ability to convert light energy into electrical current. Essentially, the solar cell functions much like a diode under illumination, exhibiting similar electrical characteristics. Consequently, the electrical behavior of a solar cell with a PN junction can be mathematically described using the following equations:

Photo-current:

$$I_{ph} = [I_{sc} + K_i \cdot (T - 298)] \cdot \frac{G}{1000} \quad (4)$$

Saturation current:

$$I_0 = I_{rs} \cdot \left(\frac{T}{T_n}\right)^3 \cdot (T - 298) \cdot \exp\left[\frac{q \cdot E_{g0} \cdot \left(\frac{1}{T_n} - \frac{1}{T}\right)}{n \cdot k}\right] \quad (5)$$

Reverse saturation current:

$$I_{rs} = \frac{I_{sc}}{e^{\left(\frac{q \cdot V_{oc}}{n \cdot N_s \cdot K \cdot T}\right) - 1}} \quad (6)$$

Current through shunt resistor:

$$I_{sh} = \left(\frac{V + I \cdot R_s}{R_{sh}}\right) \quad (7)$$

Output current:

$$I = I_{ph} - I_0 \cdot \left[\exp\left(\frac{q \cdot (V + I \cdot R_s)}{n \cdot K \cdot N_s \cdot T}\right) - 1\right] - I_{sh} \quad (8)$$

Where I_{sc} : Short-circuit current, K_i : the Temperature coefficient, T : the Temperature, G is the Incident irradiance, T_n : the Nominal temperature, q : Elementary charge, E_{g0} : Bandgap energy at reference temperature, k : Boltzmann constant, V_{oc} : Open-circuit voltage, N_s : Number of series cells, R_s : Series resistance, R_{sh} : Shunt resistance. [71]

3.1.3.3 MPPT Control strategy (Perturbation & Observation control)

The Perturbation and Observation (**P&O**) algorithm is widely recognized in the literature and in practical applications for its straightforward implementation. This method utilizes the input voltage (**V_{pv}**) and current (**I_{pv}**) values to calculate the duty cycle. It begins by perturbing the solar cell's voltage via adjustments in the duty cycle and then compares the resulting power output to its previous state. When the power output increases, the algorithm continues to adjust the duty cycle in the same direction, indicating that it is moving closer to the Maximum Power Point (**MPP**). Conversely, if the power output decreases, this signals that the MPP has been surpassed, prompting the algorithm to reverse the direction of the duty cycle adjustment. **Figure 3-3** below illustrates how the power and voltage characteristics of a solar generator vary in response to changing weather conditions.

Subsequently, the algorithm for Perturbation and Observation control will be presented:

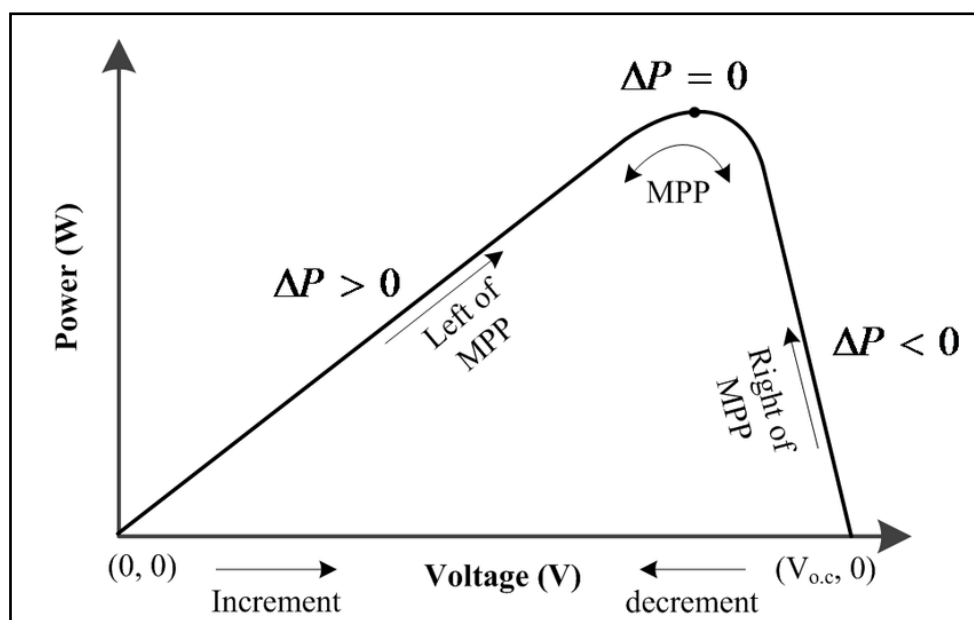

Figure 3-3 Typical Power-Voltage characteristic

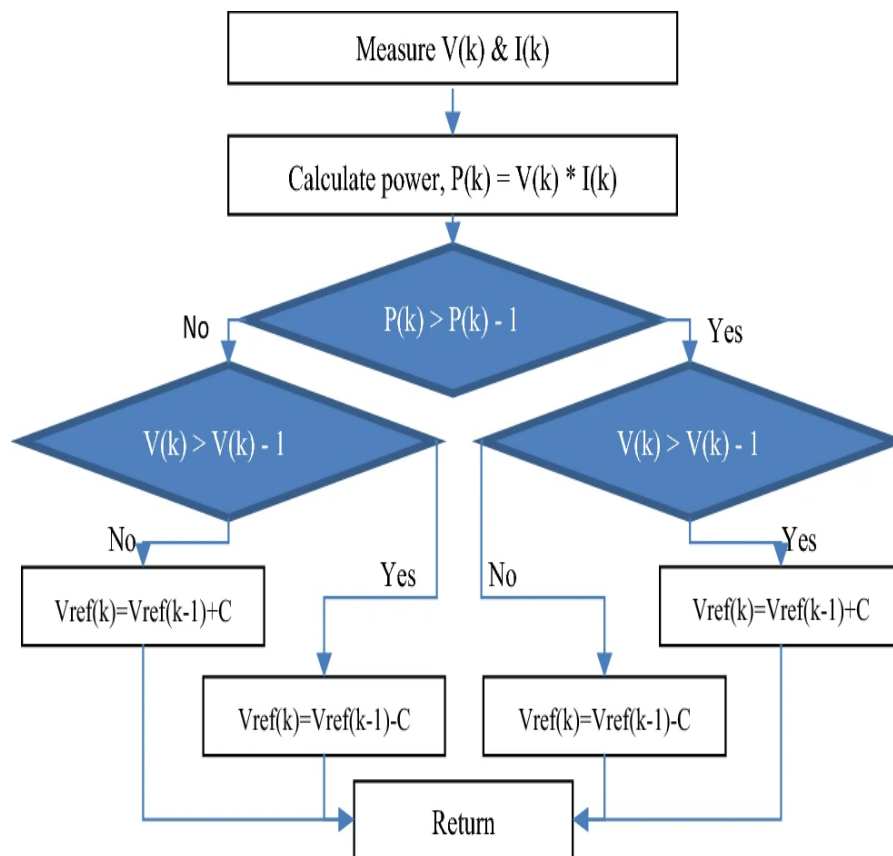

Figure 3-4 Perturbation and observation control algorithm

3.1.4 Advanced Electrolyzer Modeling

Advanced modeling techniques play a pivotal role in optimizing electrolyzer performance when integrated with renewable energy sources such as solar or wind. This section elaborates on the objectives, approaches, and outcomes of sophisticated electrolyzer modeling, emphasizing the insights from recent computational studies.

3.1.4.1 Objectives and Significance of Advanced Modeling

Advanced electrolyzer modeling serves several key objectives:

1. **Enhanced Efficiency:** Computational models aim to optimize the conversion of electrical energy into hydrogen, minimizing energy losses and enhancing system efficiency.
2. **Operational Stability:** By simulating various operational conditions, such as fluctuating renewable energy inputs, these models ensure system stability and performance reliability.
3. **Optimization of Parameters:** Modeling helps fine-tune operational parameters like temperature, pressure, and reactant flow rates, ensuring optimal electrolyzer performance across diverse scenarios.

4. **Scalability for Renewable Integration:** Advanced models address challenges posed by integrating electrolyzers with intermittent renewable energy sources, such as photovoltaic systems, enabling real-time responsiveness.

The significance of these models lies in their ability to bridge the gap between theoretical performance predictions and real-world operational complexities, ensuring that electrolyzers meet the demands of green hydrogen production efficiently.

3.1.4.2 Electrolyzer Functionality and Fundamental Reactions

Electrolyzers are electrochemical devices that use electrical energy to split water (H₂O) into its constituent gases, hydrogen (H₂) and oxygen (O₂), through a process known as water electrolysis. Among the various technologies available, proton exchange membrane (PEM) electrolyzers are favored for their compactness, dynamic response, and ability to operate at high current densities. The operation of a PEM electrolyzer involves several interdependent electrochemical and transport phenomena, including ion conduction, gas diffusion, electron flow, and heat and water management.

In the presented MATLAB/Simscape model, the electrolyzer is represented as a stack of membrane electrode assemblies (MEA), with physical and chemical parameters derived from real-world system characteristics. This section presents and explains the fundamental electrochemical equations that govern the operation of the PEM electrolyzer, as implemented in the simulation.

a. Electrochemical Reaction of Water Splitting

The core reaction in the PEM electrolyzer is the decomposition of water:



This reaction occurs in two half-cells:

- **Anodic Reaction** (Oxygen Evolution Reaction):

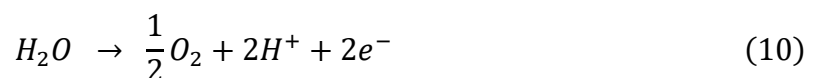

- **Cathodic Reaction** (Hydrogen Evolution Reaction):



These reactions are driven by an applied voltage and depend heavily on operating conditions such as temperature, pressure, and membrane hydration.

b. Nernst Equation (Theoretical Reversible Voltage)

The Nernst voltage gives the ideal reversible cell voltage at a given temperature and pressure:

$$V_{Nernst} = E^0 + \frac{RT}{2F} \ln \left(\frac{a_{H_2} \cdot a_{O_2}^{\frac{1}{2}}}{a_{H_2O}} \right) \quad (12)$$

where:

- E^0 is the standard cell potential (approximately 1.23 V).
- R is the universal gas constant.
- T is the temperature in Kelvin.
- F is Faraday's constant.
- a denotes the activity (or partial pressure) of each species.

This defines the standard reversible voltage E^0 , derived from the Gibbs free energy G_{H_2O} , indicating the minimum voltage needed to split water under ideal conditions.

c. Activation Losses (Tafel Equation)

Activation losses are modeled using the Tafel equation, accounting for the voltage loss due to electrochemical reaction kinetics:

$$V_{act} = E^0 + \frac{RT}{\alpha F} \ln \left(\frac{i}{i_0} \right) \quad (13)$$

where:

- i is the current density.
- i_0 is the exchange current density.
- α is the charge transfer coefficient.

This loss becomes significant at low current densities and is related to the sluggishness of the electrochemical reactions.

d. Ohmic Losses (Resistance of the Membrane)

Ohmic losses arise from the resistance to ionic and electronic flow, especially across the membrane:

$$V_{ohm} = i \cdot R_{ohm} = i \cdot \frac{t_{membrane}}{\sigma} \quad (14)$$

where:

- $t_{membrane}$ is the membrane thickness.
- σ is the membrane ionic conductivity.

This expression is used to calculate the membrane resistance per unit area, directly influencing voltage losses and efficiency.

e. Cell Voltage Equation

The actual voltage across the electrolyzer cell is the sum of the reversible voltage and all losses:

$$V_{ohm} = V_{Nernst} + V_{act} + V_{ohm} + V_{conc} \quad (15)$$

where:

- V_{conc} is the concentration overpotential (sometimes omitted in simplified models).
- Each voltage term reflects a specific physical loss mechanism in the cell.

This provides the net effective voltage available per cell, essential for calculating power and efficiency.

f. Hydrogen and Oxygen Production Rates

The stoichiometry of the electrolysis process allows direct calculation of gas production based on current:

$$\dot{n}_{H_2} = \frac{i \cdot A \cdot N}{2F}, \quad \dot{n}_{O_2} = \frac{i \cdot A \cdot N}{4F} \quad (16)$$

where:

- A is the cell area.
- N is the number of cells.
- F is Faraday's constant.

These expressions determine the mass flow rates of gases produced or consumed during the electrolysis process.

g. Thermal and Electrical Efficiency

Efficiencies are important indicators of system performance:

$$\eta_{HHV} = \frac{V_{Cell}}{HHV_{H_2}/(2F)}, \quad \eta_{LHV} = \frac{V_{Cell}}{LHV_{H_2}/(2F)} \quad (17)$$

where:

- HHV_{H_2} and LHV_{H_2} are the higher and lower heating values of hydrogen.

These equations normalize the cell voltage to energy content, giving a clear view of system performance.

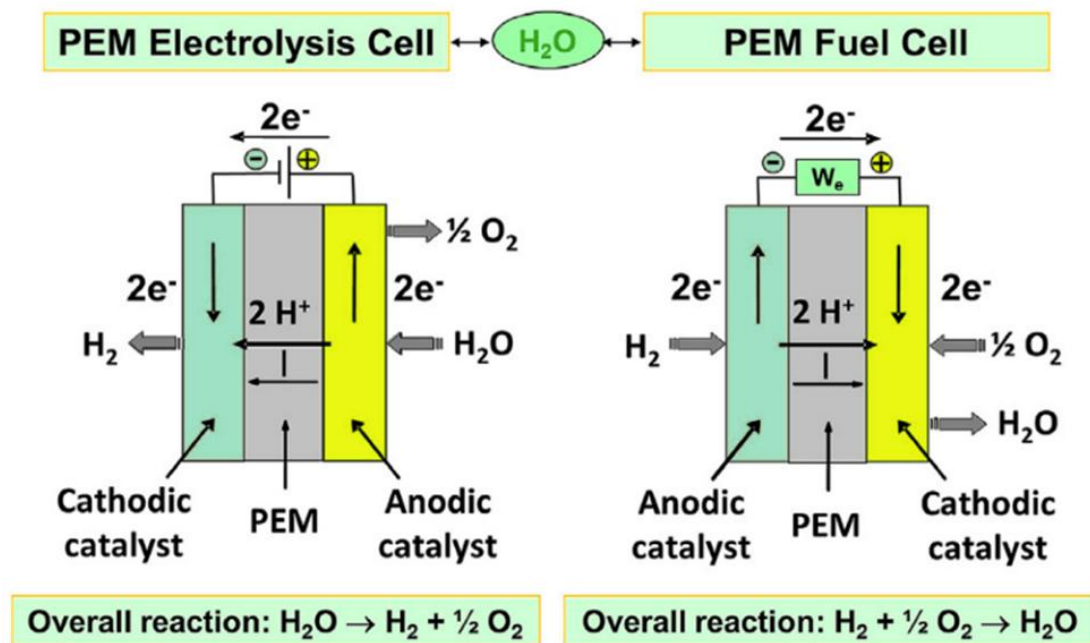

Figure 3-5 Schematic representation of Electrolyzer and Fuel Cell [72]

3.1.4.3 Key Modeling Approaches

Electrolyzer modeling techniques range from simplified analytical methods to complex numerical simulations:

1. Analytical Models:

- These models use simplified mathematical expressions to simulate key electrolyser behaviours, such as polarization curves and energy efficiency.
- Although they are computationally efficient, their application is limited to specific scenarios and predefined operating conditions.

2. **Empirical and Semi-Empirical Models:**

- Derived from experimental data, these models predict electrolyser performance under varied conditions using empirical formulas.
- While more accurate than analytical models, they are constrained by the specific configurations of the systems from which data is collected.

3. **Numerical Mechanical Models:**

- These are highly detailed models that simulate the electrochemical and physical phenomena occurring within an electrolyser.
- They solve complex differential and algebraic equations to predict polarization, reactant concentrations, and system losses with high accuracy.
- Although these models provide detailed insights, their computational intensity can make them impractical for real-time applications.

3.1.4.4 **Modelling Of the Proposed System**

This study focuses on the modelling and simulation of an advanced electrolyser system, employing MATLAB Simulink as the primary tool for detailed analysis and optimization. The system is designed with two primary sections: the anode side and the cathode side, each configured to maximize operational efficiency and ensure reliability.

On the **anode side**, the design incorporates fluid channels that are strategically connected to a heat exchanger to regulate thermal conditions and maintain optimal operating temperatures. A recirculation system is integrated to enhance water utilization efficiency and reduce waste, while a water tank serves as a continuous and reliable water source for the electrolysis process.

Conversely, the **cathode side** features fluid channels linked to a dehumidifier unit. This dehumidifier is engineered to effectively separate water vapor from the hydrogen gas produced during the electrolysis process. The extracted hydrogen is subsequently stored in a dedicated hydrogen storage tank for later use. To ensure the overall system operates within safe and efficient temperature ranges, a sophisticated cooling system is implemented to stabilize the thermal dynamics of the electrolyzer.

After designing the model, it was essential to feed it with accurate physical parameters that reflect real-world behavior as closely as possible.

The modeled PEM Electrolyzer was represented schematically as shown in Figure 3-6

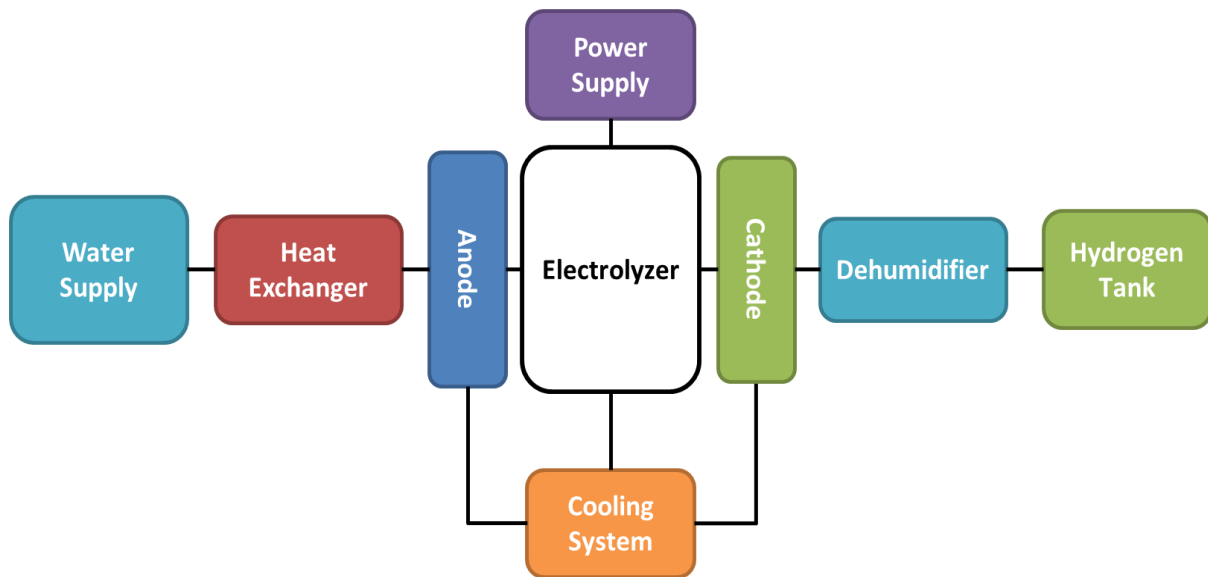

Figure 3-6 Advanced Electrolyzer Simulation

And the **Table 3-1** presents a set of values used in the simulation, derived from scientific and industrial references to ensure reliable results under realistic operating conditions

Table 3-1 Physical Parameters Used for the Electrolyzer

Parameter	Value	Unit
Number of cells	50	–
Cell area	280	cm ²
Membrane thickness	125	µm
Reference current	8e-5	A/cm ²
Proton transfer coef.	0.5	–

While the **Figure 3-7** shows Advanced Electrolyzer Model in MATLAB/Simulink.

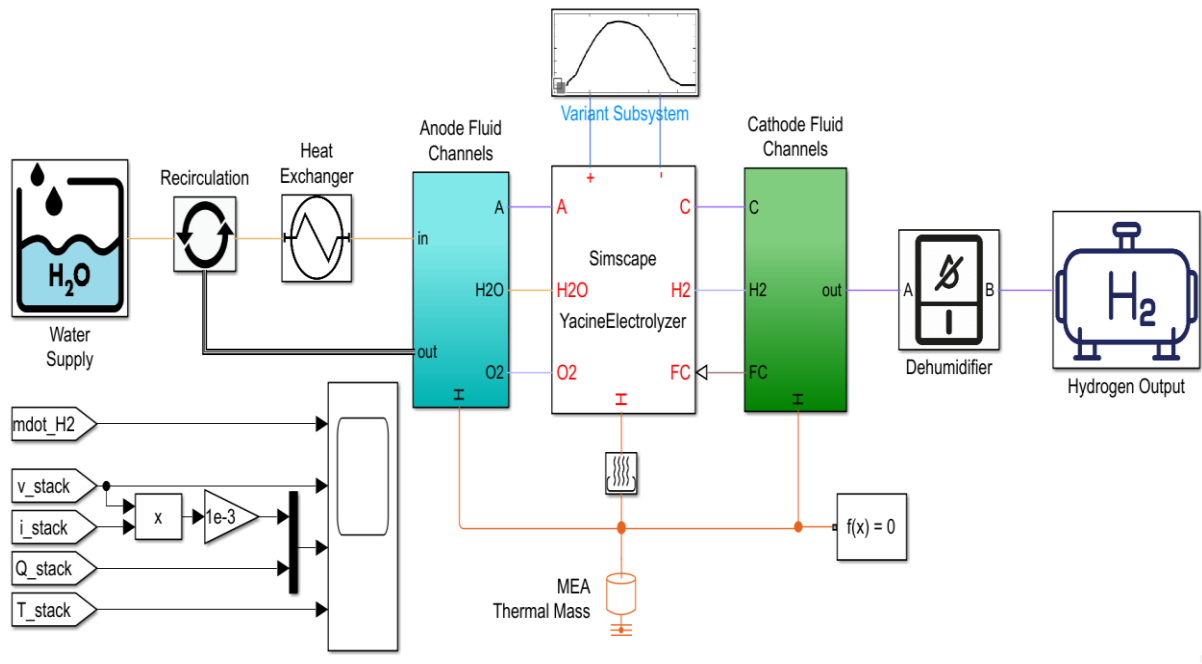

Figure 3-7 Advanced Electrolyzer MATLAB Model

For the energy input, the system is evaluated under three distinct power profiles to assess its adaptability and performance under varying conditions. These include:

1. A **solar power profile**, representing the intermittent and variable nature of renewable energy sources;
2. A **step current profile**, simulating sudden and discrete changes in power demand; and
3. A **ramp current profile**, which represents gradually increasing or decreasing power supply scenarios.

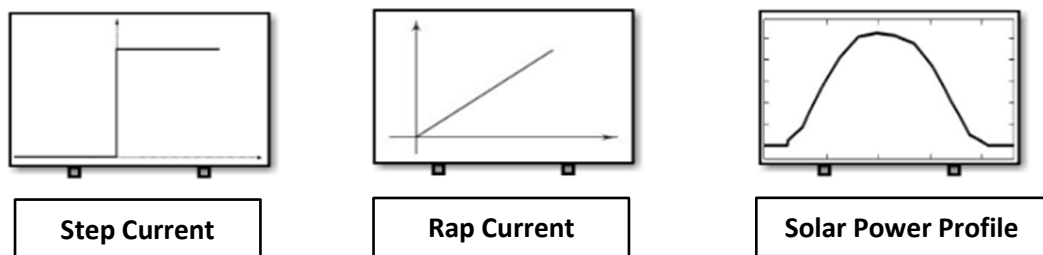

Figure 3-8 Power Source Profiles

This comprehensive modeling approach provides a robust framework for understanding the interplay between system components, optimizing efficiency, and assessing the feasibility of integrating renewable energy sources into hydrogen production technologies.

3.1.5 Simulation Results

A. Energy source

In this simulation, an irradiation value of 1000 W/m² is assumed, alongside a constant temperature of 25°C. These conditions are selected to rigorously assess the effectiveness of the Perturbation and Observation (P&O) strategy used in the DC/DC converter.

Table 3-2 PV Model Characteristics

PV Model : SPR-225-BLK-U	
Maximum power	$P_{mpp} = 213.15 \text{ W}$
Voltage of maximal power	$V_{mpp} = 29 \text{ V}$
Current of maximal power	$I_{mpp} = 7.35 \text{ A}$
Open-circuit Voltage	$V_{OC} = 36.3 \text{ V}$
Short-circuit current	$I_{SC} = 7.84 \text{ A}$
Cell numbers	60
Temperature coefficient of the maximum power	- 0.360%
Reference temperature	$T_r = 25\text{oC}$
Boltzmann Constant	$K = 1.3805 \cdot 10^{-23} \text{ J/K}$
Electron charge	$q = 1.6 \cdot 10^{-19} \text{ C}$

The simulation results demonstrate the impressive adaptability and stability of the photovoltaic (PV) system under varying irradiation conditions. Specifically, the system consistently achieves its maximum power output throughout the simulation, effectively harnessing solar energy even as irradiation levels fluctuate.

Moreover, the system exhibits outstanding external voltage regulation, reliably maintaining a steady voltage at the prescribed reference of 48 V. Even with changes in irradiation, the system swiftly realigns with this reference value, highlighting its robust voltage control and resilience in dynamic environmental conditions.

Similarly, the battery current remains remarkably stable, closely tracking the designated reference value (IBref) with only minor oscillations. This consistency reflects the efficiency of the battery management system, ensuring optimal charging and discharging processes that maximize energy storage performance and prolong battery life.

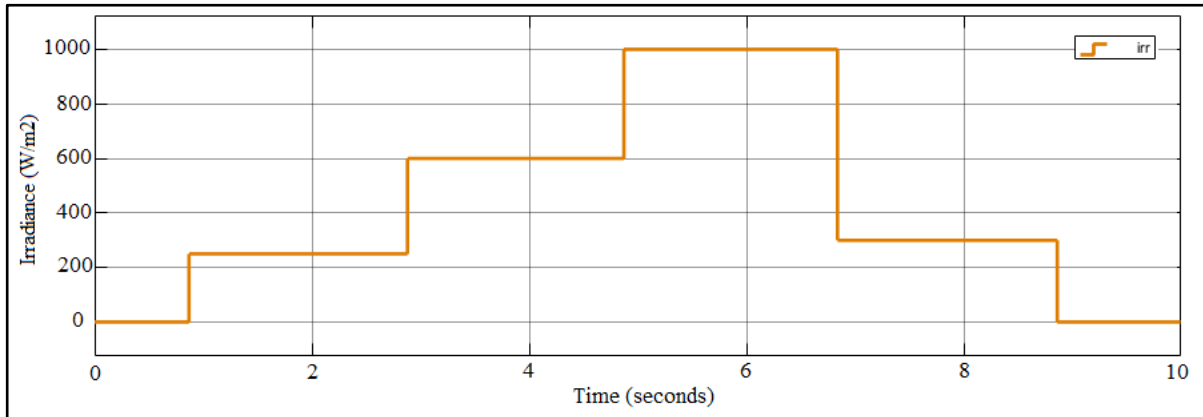

Figure 3-9 Temporal Variation of Irradiance

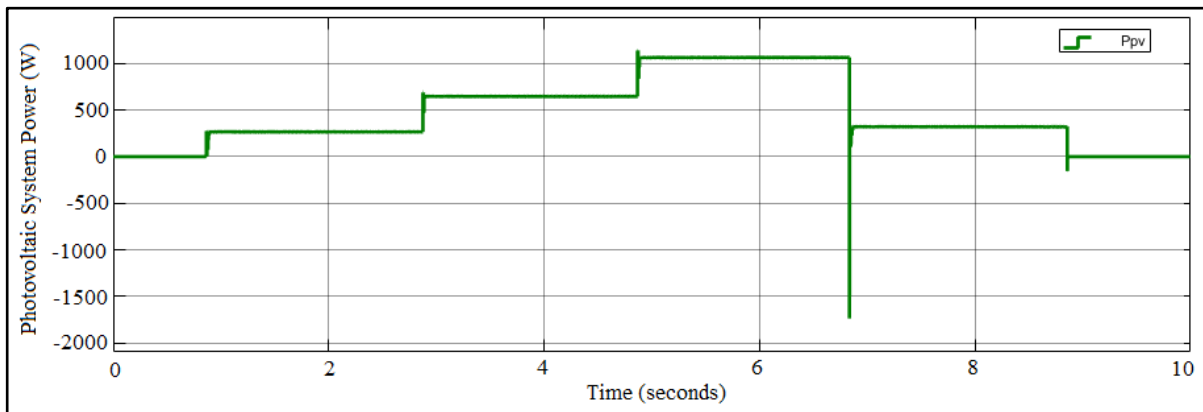

Figure 3-10 Photovoltaic System Power Output

In essence, the comprehensive analysis of the simulation data provides valuable insights into the PV system's reliability and performance under dynamic environmental conditions. Its capability to sustain peak power output, regulate external voltage, and stabilize battery current underscores its potential for various renewable energy applications, reinforcing confidence in its practical implementation for sustainable energy generation and storage.

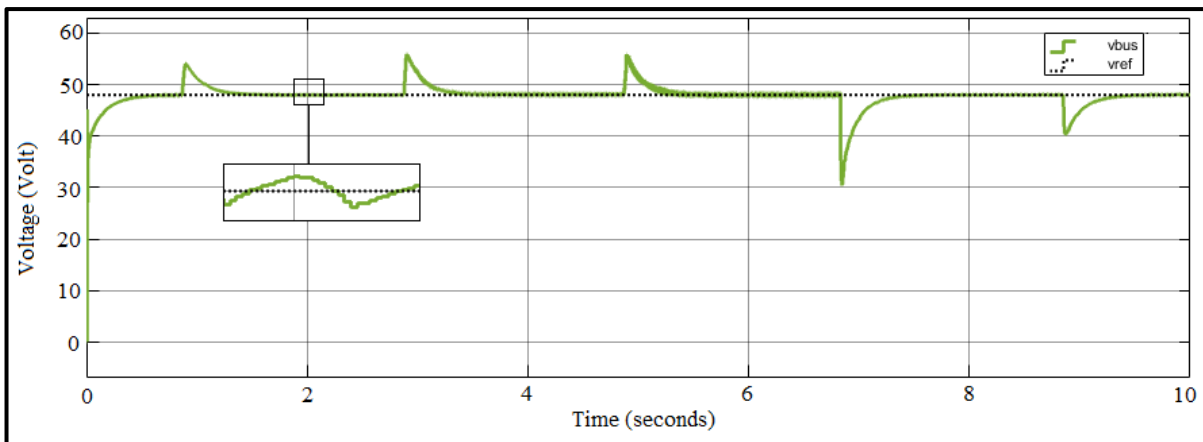

Figure 3-11 Photovoltaic System Voltage Output

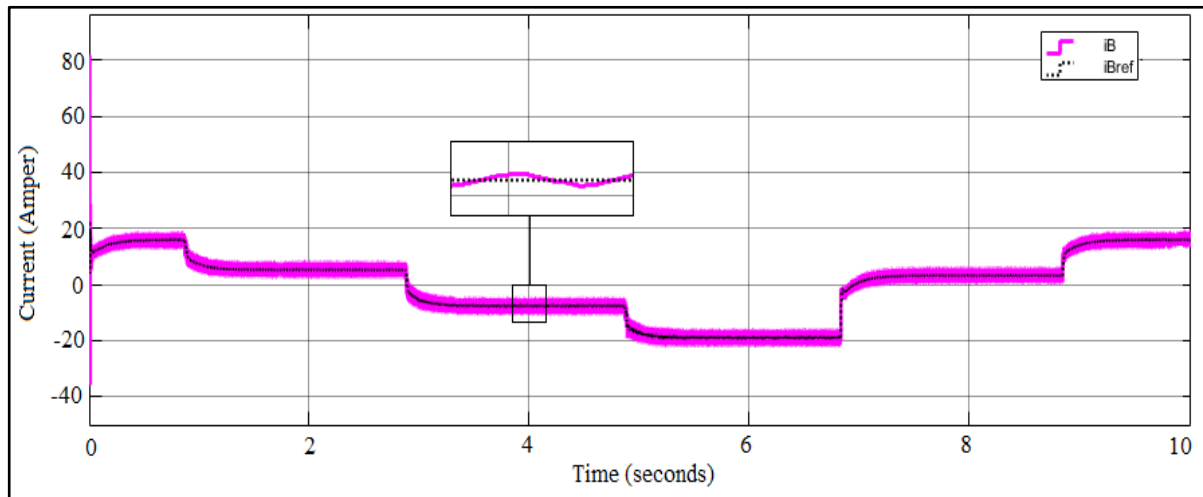

Figure 3-12 Battery charging current

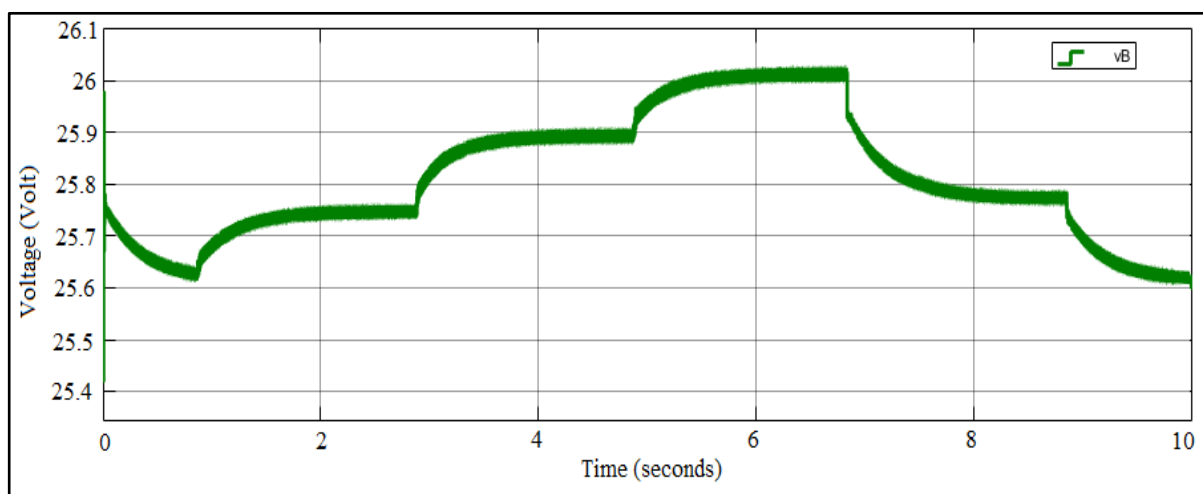

Figure 3-13 Battery voltage

B. Electrolyzer

The simulation results provide valuable insights into the performance of the proposed system under different energy profiles.

In the **solar configuration** (Figure 3-13), the rate of hydrogen production is directly influenced by the intensity of incident light. As the light intensity increases, hydrogen production rises proportionally, peaking at **0.52 g/s**. Conversely, as light intensity diminishes, the production rate decreases. A similar trend is observed in energy output, which increases with light intensity, reaching a maximum of **100 kW**, before decreasing as light intensity subsides. Due to the surplus energy exceeding the system's required input, the excess energy dissipated as heat reaches a peak of **22 kW**. The electrolyzer temperature exhibits a continuous increase alongside hydrogen production, stabilizing at **80 °C** due to the operation of the cooling system. This thermal stabilization ensures that system performance and efficiency are maintained without degradation from excessive temperatures.

For the **Step Profile** (Figure 3-14), the hydrogen production rate initially rises sharply from **0 to 0.43 g/s** before stabilizing in response to the consistent power supply. The energy output mirrors this behavior, jumping from **0 to 80 kW** and then remaining constant. The heat dissipation in this scenario is steady at **20 kW**, while the cooling system effectively maintains the electrolyzer temperature at **80 °C**, ensuring stable operation.

In the **Ramp Profile** (Figure 3-15), hydrogen production exhibits a gradual increase, reaching **0.45 g/s**, with a continuous upward trajectory. The power supply follows a similar pattern, gradually increasing to **80 kW**. The electrolyzer temperature rises alongside these parameters, stabilizing at **80 °C** due to the efficient performance of the cooling system.

The results demonstrate that the system's power input consistently exceeds the minimum energy required for hydrogen production, primarily due to various system losses. This surplus manifest as dissipated heat, with thermal efficiency calculated at approximately **87%**, based on the calorific value of the produced hydrogen. This efficiency underscores the system's capability to convert electrical energy into hydrogen effectively. Furthermore, the cooling system ensures thermal stability, maintaining the electrolyzer's temperature below the critical threshold of **80 °C**, thus preserving operational integrity and optimizing performance.

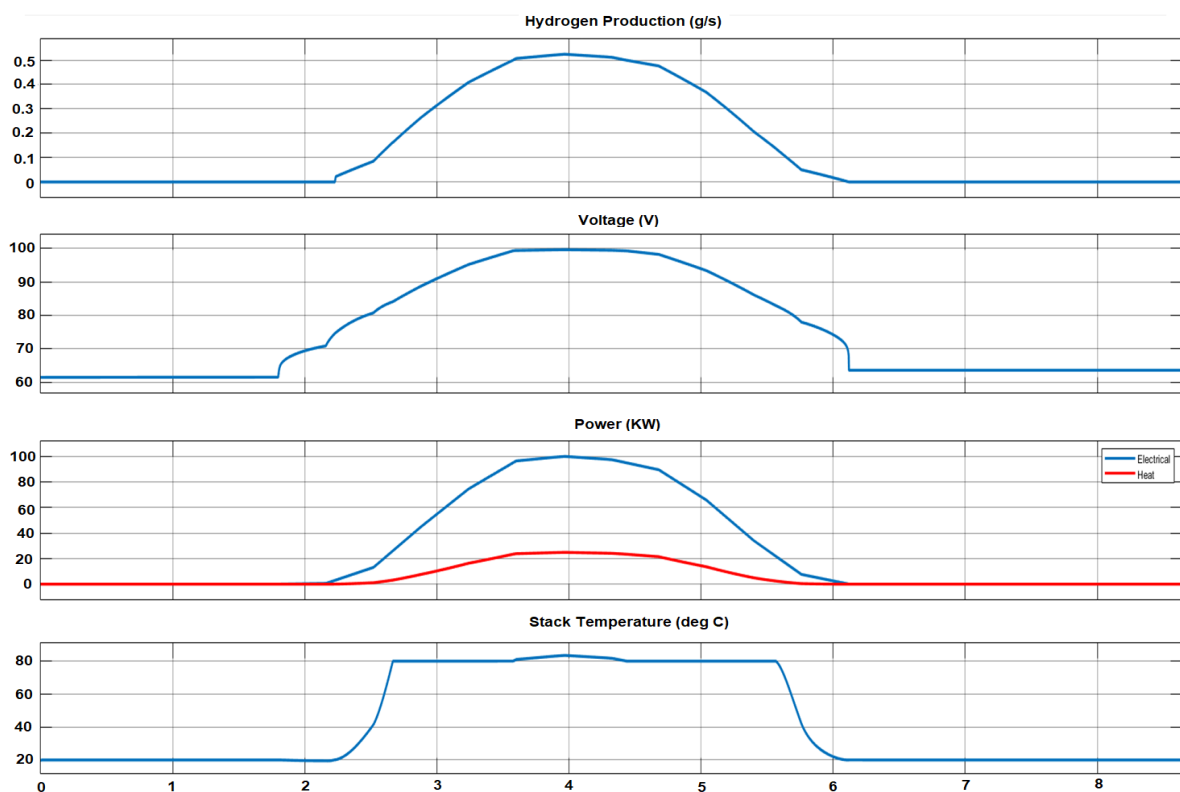

Figure 3-14 Solar Power Profile Graphs

Improving the performance of energy systems from renewable sources based on green hydrogen
 Chapter 3: Advanced Systems for Green Hydrogen Production

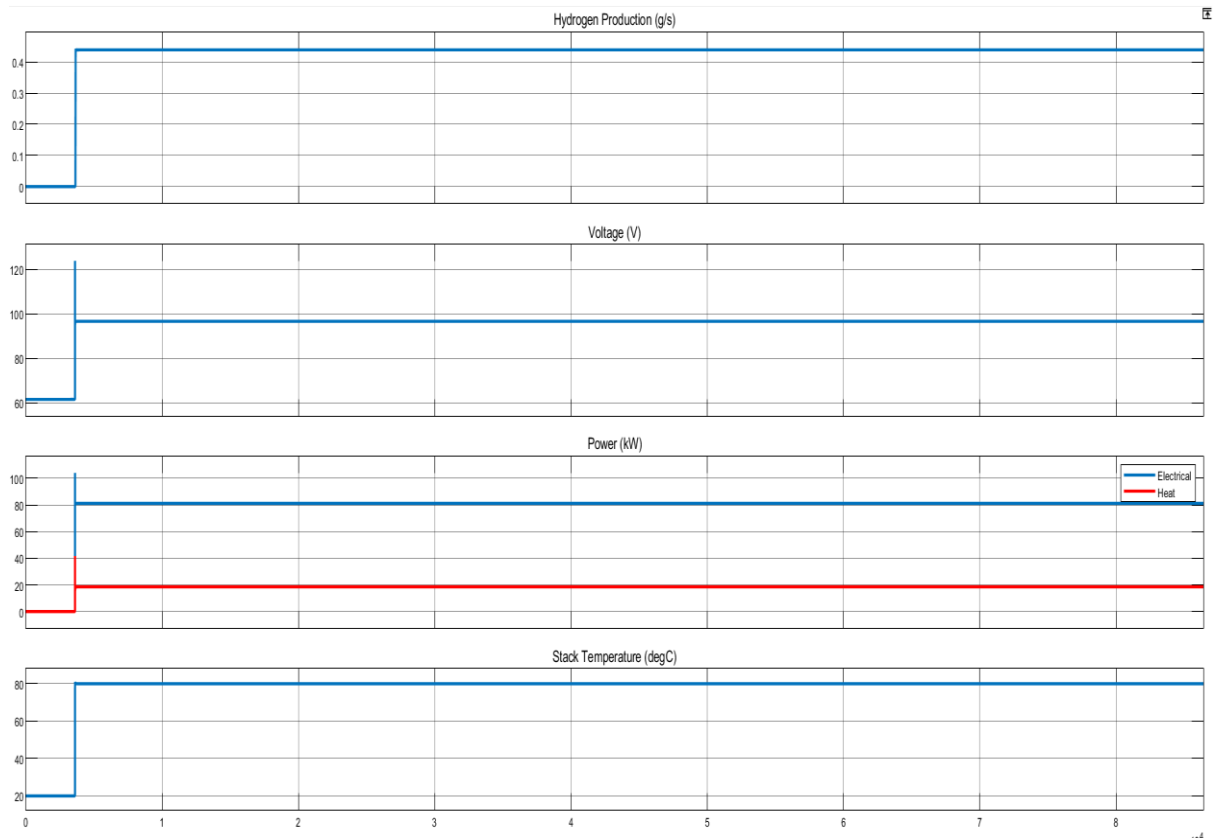

Figure 3-15 Step Profile Graphs

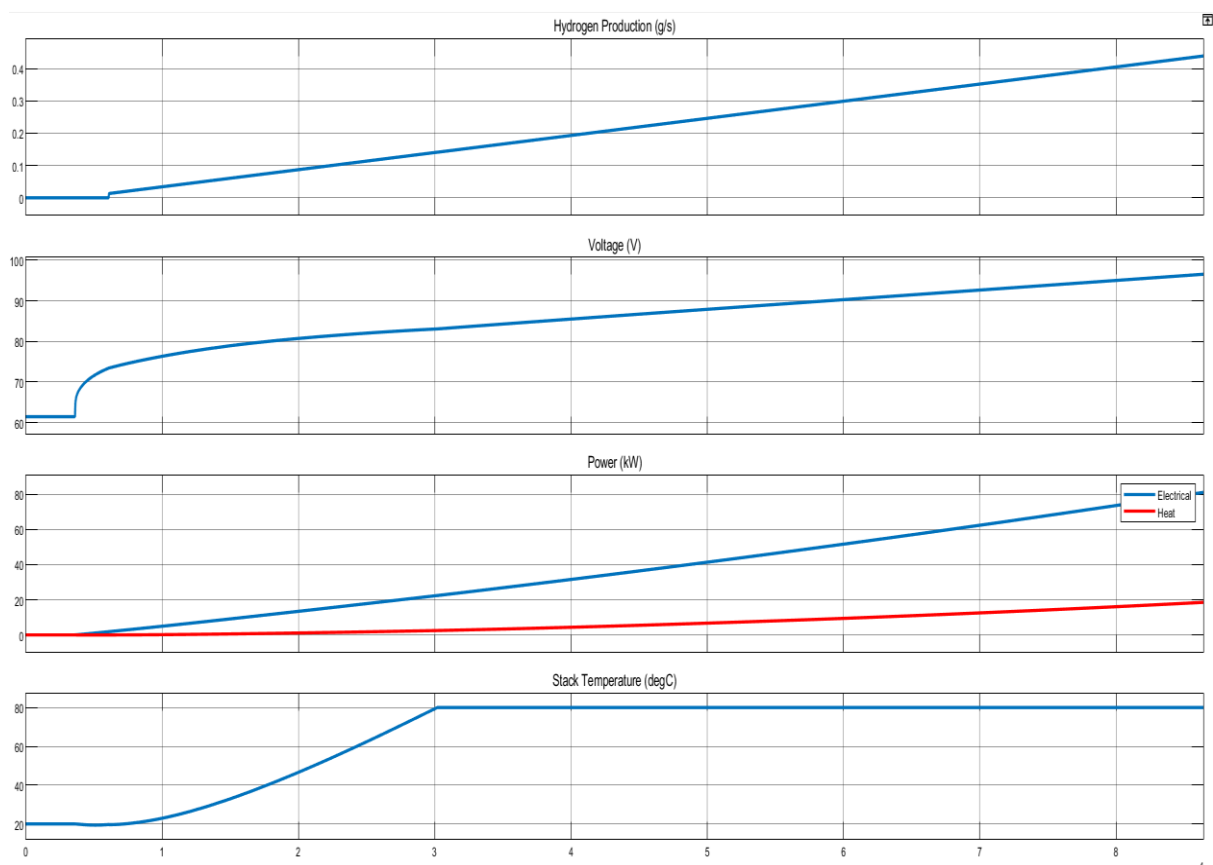

Figure 3-16 Ramp Profile Graphs

3.1.6 Comment On The Results

This work provides a comprehensive investigation into the optimization of an autonomous photovoltaic (PV) solar system. The study introduces a novel approach based on the perturbation and observation methodology, specifically designed to maximize PV power extraction. Rigorous simulated experiments conducted using MATLAB Simulink within a boost converter-based configuration have been employed to assess the strategy's efficacy.

The simulation results unambiguously confirm the strategy's effectiveness in tracking the Maximum Power Point (MPP) and optimizing power harvesting under variable solar environmental conditions. This robust performance highlights the perturbation and observation technique as a reliable and adaptable method for enhancing PV system performance.

Furthermore, utilizing MATLAB Simscape, a sophisticated electrolyzer system was developed, characterized by an advanced design that consistently achieved an impressive 87% yield. This milestone not only demonstrates the robustness and effectiveness of the design methodology but also reinforces the potential for future advancements in electrolysis technology.

One of the key challenges identified in this work is the design of an effective and practical cooling system to ensure the overall stability of the integrated system. This issue will be the primary focus of forthcoming investigations.

Additionally, future research will concentrate on identifying and implementing an optimal control strategy to efficiently manage the electrolyzer within the integrated PV system. A comparative analysis between the obtained results and those derived from a fully validated model is also planned, to verify the accuracy of the findings. This multifaceted exploration is poised to unlock new opportunities for sustainable energy generation and storage, paving the way for a greener and more resilient energy infrastructure.

3.1.7 Example Applications and Future Directions

The findings underscore the potential of integrating PV systems into hydrogen production infrastructure, particularly in sun-rich regions like Algeria. Future advancements could focus on hybrid renewable systems combining PV with wind energy to further enhance reliability and output. Furthermore, scaling up such systems could position Algeria as a leading exporter of green hydrogen to European markets.

The role of photovoltaic (PV) technology in enabling efficient hydrogen production is undeniably transformative. Innovations in PV technology and system design address critical challenges, including energy conversion efficiency, environmental adaptability, and scalability. By incorporating advanced technologies, Algeria can optimize its abundant solar resources and position itself as a global leader in green hydrogen production.

A. Bifacial Solar Panels: Unlocking the Full Potential of Solar Energy

Bifacial solar panels represent a leap forward in PV technology, capable of harvesting sunlight from both the front and rear surfaces. This dual-sided absorption mechanism is particularly beneficial in high-albedo environments such as deserts, where reflected sunlight from sand significantly enhances energy output. Research indicates that bifacial panels can increase energy generation by up to 20%, making them an ideal choice for Algeria's southern regions with their vast desert landscapes. Additionally, these panels exhibit superior durability and longer operational lifespans, reducing the overall cost per kilowatt-hour and enhancing the feasibility of large-scale green hydrogen projects. [73]

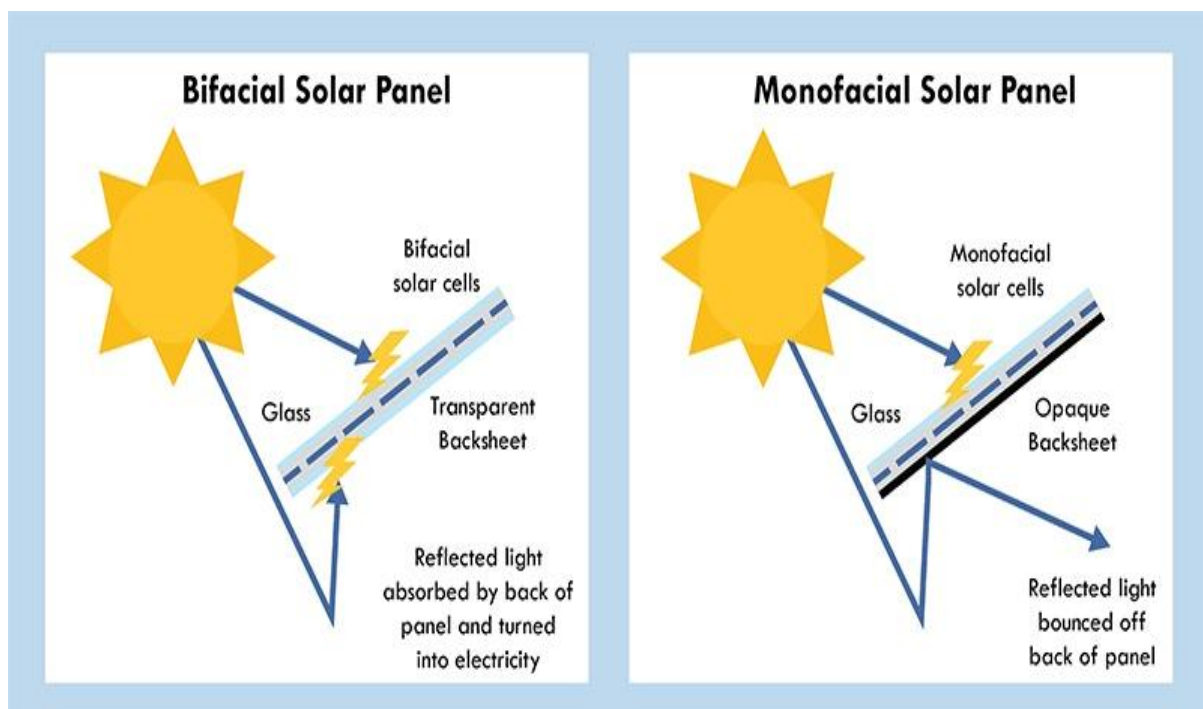

Figure 3-17 Bifacial vs. Monofacial Panels

Table 3-3 Efficiency comparison of bifacial vs. Monofacial panels [73]

Feature	Monofacial solar panel	Bifacial solar panel
Sunlight absorption	Front side only	Both front and rear sides
Efficiency	Standard efficiency, reliant on direct sunlight	Up to 30% higher efficiency by using reflected light
Energy output	Limited to direct sunlight	Increased output from rear side reflection
Design	Opaque backing	Transparent or semi-transparent backing
Ideal use	Rooftops or non-reflective areas	Open Spaces with reflective surfaces
Durability	Standard durability	More durable with glass back design
Cost	Lower upfront cost	Higher upfront cost but better long-term ROI
Appearance	Traditional opaque panels	Sleek modern transparent design

B. Advanced Cooling Systems: Ensuring Performance in High-Temperature Climates

The efficiency of PV systems can degrade substantially in high-temperature environments, a common challenge in Algeria's arid regions. Advanced cooling systems, such as passive radiative cooling and liquid cooling technologies, have emerged as critical solutions to mitigate thermal losses.

- **Passive radiative cooling** utilizes materials that dissipate heat by emitting infrared radiation, reducing the operating temperature of PV cells without the need for external energy inputs.
- **Liquid cooling systems**, on the other hand, use circulating fluids to absorb and transfer heat away from the PV modules, maintaining optimal performance.

These technologies ensure stable power output and consistent hydrogen production, even under extreme climatic conditions, addressing one of the primary barriers to the widespread adoption of solar energy in desert regions. [74]

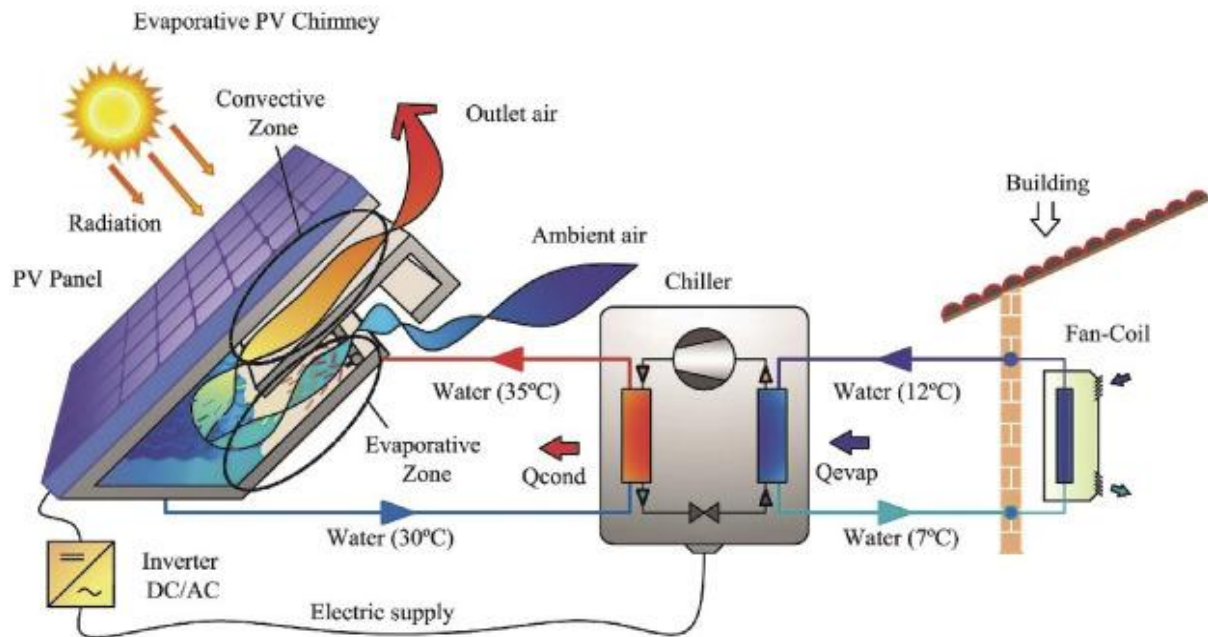

Figure 3-18 Advanced cooling systems for PV panels

C. Hybrid Renewable Energy Systems: Enhancing Reliability and Scalability

Hybrid systems that combine PV technology with other renewable sources, such as wind energy, offer a robust solution to solar intermittency. Algeria's diverse climatic zones provide a unique advantage for deploying such systems, where regions with high solar irradiance can be complemented by areas with strong and consistent wind patterns. Hybrid configurations not only improve the reliability and scalability of renewable energy systems but also enable 24/7 operation of electrolysis units for hydrogen production. This approach ensures a continuous supply of green hydrogen, addressing both domestic energy demands and export opportunities. [75]

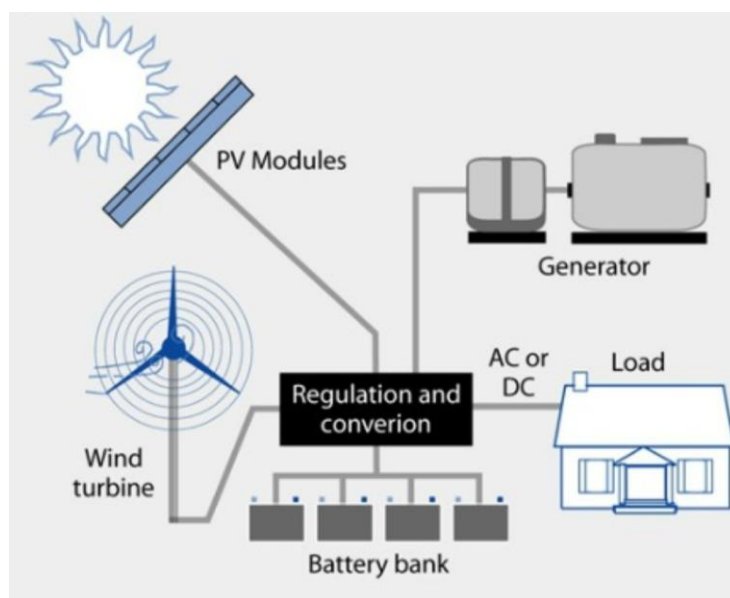

Figure 3-19 Diagram of a hybrid PV-wind system

3.1.8 Future Research Directions: Pioneering New Frontiers

To fully capitalize on advancements in PV and system design, strategic research and innovation are essential. Key areas of focus include:

1. **AI-Based Control Systems for Energy Management:** Artificial intelligence (AI) algorithms can optimize energy flow in complex renewable systems, ensuring maximum efficiency in power generation and hydrogen production. Predictive analytics can also forecast energy demand and supply, further enhancing system reliability.
2. **Sustainable Water Sourcing for Electrolysis:** Addressing the water-energy nexus is crucial for green hydrogen production in arid regions. Innovative methods, such as desalination powered by renewable energy or the use of treated wastewater, can provide sustainable solutions for water sourcing in electrolysis processes.
3. **Utilizing Existing Gas Pipelines for Hydrogen Transport:** Leveraging Algeria's established natural gas infrastructure to transport hydrogen to European markets presents a cost-effective and scalable export strategy. Research into pipeline retrofitting and hydrogen-compatible materials is necessary to facilitate this transition.

Algeria's immense solar potential, coupled with advancements in PV technology and system design, positions the country to lead the green hydrogen revolution. Bifacial solar panels, advanced cooling systems, and hybrid renewable configurations are critical innovations that address efficiency and adaptability challenges. By focusing on future research in AI-based management, sustainable water solutions, and infrastructure optimization, Algeria can establish itself as a global hub for green hydrogen production, driving energy sustainability and economic growth.

3.2 Electrolysis Methods

Electrolysis is a fundamental process in the production of green hydrogen, enabling the splitting of water into hydrogen and oxygen molecules through the application of electricity. The selection of electrolysis method plays a crucial role in determining the efficiency, cost-effectiveness, and scalability of hydrogen production systems. This section explores the various electrolysis techniques, innovative water sourcing solutions, and their integration with renewable energy sources.

3.2.1 Types of Electrolysis

Electrolysis methods are distinguished by their operating conditions, efficiency, and suitability for integration with renewable energy. The three dominant methods Alkaline Electrolysis (AE), Proton Exchange Membrane (PEM) Electrolysis, and Solid Oxide Electrolysis (SOE) each offer unique advantages and limitations.

1. Alkaline Electrolysis (AE):

Alkaline electrolysis operates at temperatures ranging from 40 to 90°C, utilizing a liquid alkaline solution such as potassium hydroxide as the electrolyte. This mature technology is cost-effective, making it widely adopted in industrial settings. However, AE systems are less efficient than other methods, with efficiencies between 55% and 70%, and exhibit slow dynamic responses to power fluctuations, limiting their compatibility with variable renewable energy sources like solar and wind. [15]

2. Proton Exchange Membrane (PEM) Electrolysis:

PEM electrolysis employs a solid polymer electrolyte membrane, operating at efficiencies of up to 75% within a temperature range of 50 to 80°C. The compact design and rapid dynamic response of PEM systems make them highly suitable for integration with intermittent renewable energy sources. Despite these advantages, the reliance on platinum-based catalysts increases costs, posing challenges for large-scale deployment.

3. Solid Oxide Electrolysis (SOE):

SOE functions at high temperatures of 500–800°C, leveraging ceramic electrolytes to achieve exceptional efficiencies of 80–90%. This method is ideal for industrial-scale hydrogen production, especially when integrated with waste heat recovery systems. However, the high operating temperatures impose significant material challenges, increasing maintenance and infrastructure costs. [15]

Table 3-4 Comparison of Electrolysis Methods

Method	Efficiency (%)	Operating Temperature (°C)	Summary of Benefits and Drawbacks
AE	55–70	40–90	Cost-effective but low efficiency and slow dynamic response.
PEM	65–75	50–80	Compact, fast response, but high cost due to catalysts.
SOE	80–90	500–800	High efficiency, industrial-scale potential, but material challenges.

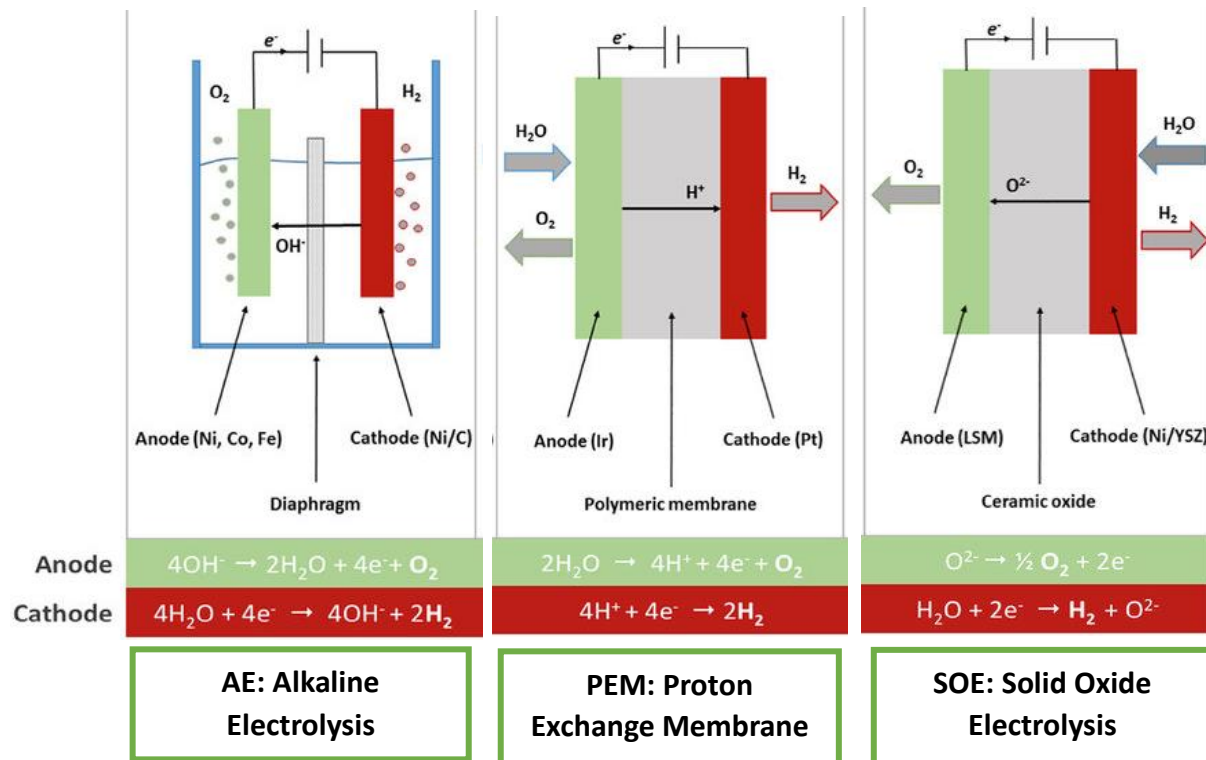

Figure 3-20 Types of Electrolysers

3.2.2 Innovative Water Sourcing Solutions

Given Algeria's arid climate, sustainable water sourcing is a critical aspect of implementing electrolysis for hydrogen production. Two key strategies have emerged to address this challenge:

1. Seawater Electrolysis:

- Direct seawater electrolysis eliminates the need for pre-treatment desalination processes. Emerging technologies utilize advanced membranes and catalysts that resist fouling and corrosion caused by salt and other impurities in seawater.
- **Potential in Algeria:** With a coastline of over 1,600 km, Algeria has significant potential to harness seawater for hydrogen production. Pilot projects globally, such as those in Australia and Saudi Arabia, showcase the viability of this approach.

2. Wastewater Utilization:

- Treated wastewater offers a dual solution: addressing water scarcity and providing a source for electrolysis. Advanced treatment methods ensure that contaminants do not compromise the efficiency of electrolyzers.

- **Case Study:** In urban areas with high population densities, wastewater can be a reliable and sustainable resource. For example, in Algiers, wastewater plants could potentially provide a stable supply for localized hydrogen production.

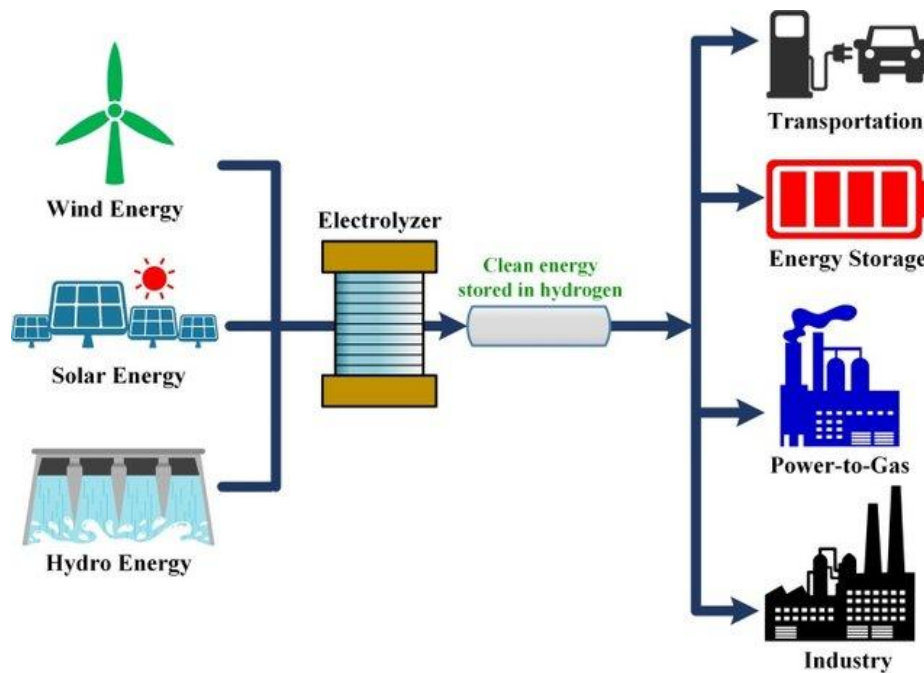

Figure 3-21 Water Electrolysis Process Using Renewable Energy [76]

3.2.3 Integration with Renewable Energy

The success of electrolysis technologies is closely linked to their integration with renewable energy sources. This ensures that hydrogen production remains carbon-neutral and cost-effective. Key considerations include:

- **Energy Matching:** PEM electrolyzers are better suited for intermittent solar and wind power due to their rapid response times, whereas AE and SOE systems require stable energy inputs.
- **Hybrid Systems:** Combining PV and wind energy can provide a more consistent power supply, optimizing electrolyzer efficiency.

3.2.4 Future Prospects and Recommendations

To maximize Algeria's green hydrogen potential, a multifaceted strategy is essential. Scaling up seawater electrolysis projects along Algeria's extensive 1,600 km coastline can leverage advanced desalination technologies to mitigate water scarcity issues. Simultaneously, hybrid

renewable energy systems combining solar and wind power should be prioritized to provide stable and cost-effective electricity for hydrogen production. Investments in research and development can drive the discovery of alternative, cost-effective catalysts for PEM and SOE systems, reducing reliance on expensive materials like platinum. Additionally, Algeria's existing natural gas infrastructure offers an opportunity for repurposing pipelines to transport green hydrogen to European markets, enhancing export capabilities and global competitiveness. By adopting these measures, Algeria can position itself as a leader in the global transition to sustainable energy.

3.3 Utilizing Digital Twins to Enhance Fuel Cell Efficiency

Digital twins represent a transformative paradigm in energy systems, particularly for **fuel cells**, by creating a virtual replica that dynamically mirrors the real system's behavior. This digital counterpart leverages **real-time data** and advanced simulations to optimize performance, detect anomalies, and predict maintenance needs. The integration of **digital twins** with **fuel cell technology** holds substantial potential for enhancing efficiency, reliability, and operational stability.

3.3.1 Theoretical Foundations and Principles

A. Definition and Core Functions:

A digital twin is a virtual model that replicates the physical attributes, operational parameters, and behavior of a real-world system. It integrates data from various sensors and operational feedback to simulate processes in real time. This approach allows continuous comparison between the actual system and its digital counterpart, facilitating anomaly detection, performance evaluation, and predictive maintenance.

B. Key Components:

1. **Data Integration Layer:** Collects data from the fuel cell's sensors (temperature, pressure, voltage, and current) and feeds it into the digital model.
2. **Simulation Core:** Utilizes advanced modelling software (e.g., **MATLAB Simscape**) to simulate the electrochemical processes and thermal dynamics within the fuel cell stack.
3. **Analytics Engine:** Processes the data to identify performance trends, predict failures, and recommend optimizations.

C. Applications in Fuel Cells:

- **Performance Optimization:** By simulating different operating conditions, digital twins help fine-tune fuel cell parameters, such as reactant flow rates, humidity levels, and temperature control, to maximize efficiency.
- **Fault Diagnosis:** Detects deviations from expected performance, identifying issues like membrane degradation, catalyst poisoning, or gas leakage before they cause system failures.
- **Predictive Maintenance:** Forecasts maintenance needs based on operational data, reducing downtime and extending the fuel cell's lifespan.

3.3.2 Case Study: Advanced PEM Fuel Cell Digital Twin

A. Objective:

The study aimed to develop a digital twin for **Proton Exchange Membrane Fuel Cells (PEMFCs)** using **MATLAB Simscape**. The virtual model replicates the fuel cell's electrochemical behavior, providing a reference for monitoring and error detection.

B. Functionality and Fundamental Reactions of the PEM Fuel Cell:

The proton exchange membrane (PEM) fuel cell is a clean electrochemical device that converts chemical energy from hydrogen and oxygen into electricity, with water and heat as by-products. It operates at relatively low temperatures (typically 60–80°C) and is characterized by high efficiency, fast start-up, and a compact design, making it suitable for both stationary and mobile applications. The core of the PEM fuel cell consists of a membrane electrode assembly (MEA), where the electrochemical reactions occur across three primary layers: the anode, the polymer electrolyte membrane, and the cathode.

In this model, a fuel cell stack is composed of multiple MEAs connected in series. Hydrogen gas is supplied to the anode side, where it is oxidized, releasing protons and electrons. The protons migrate through the membrane to the cathode, while the electrons flow through an external circuit, providing useful electrical power. At the cathode, oxygen gas reacts with the incoming protons and electrons to form water. These fundamental processes are governed by a series of thermodynamic and electrochemical equations, detailed below.

1. Electrochemical Reactions

The basic half-cell reactions that take place in the PEM fuel cell are:

- **Anode (Hydrogen oxidation):**



- **Cathode (Oxygen reduction):**

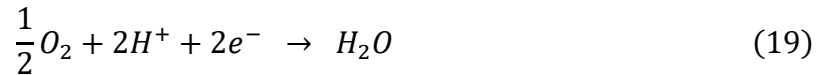

- **Overall cell reaction :**



This net reaction releases Gibbs free energy, part of which is converted into electrical energy.

2. Theoretical Open-Circuit Voltage (Nernst Potential)

The maximum potential the cell can produce under reversible and ideal conditions is given by the Nernst equation:

$$V_{Nernst} = E^0 + \frac{RT}{2F} \ln \left(\frac{a_{H_2} \cdot a_{O_2}^{\frac{1}{2}}}{a_{H_2O}} \right) \quad (21)$$

where:

- E^0 Standard reversible cell potential, derived from the Gibbs free energy of water formation ($E^0 = \frac{-\Delta G}{2F}$).
- R is the universal gas constant.
- T is Stack operating temperature in Kelvin.
- F is Faraday's constan.
- a Activity of the species i , approximated by partial pressure or mole fraction.

This equation adjusts the theoretical voltage to reflect non-standard operating conditions.

3. Activation Losses (Tafel Equation)

Activation losses are associated with the kinetics of the electrochemical reactions, primarily the oxygen reduction reaction (ORR) at the cathode. These losses are expressed using the Tafel equation:

$$V_{act} = b \cdot \ln\left(\frac{i_{cell}}{i_0}\right) \quad (22)$$

where:

- $b = \frac{RT}{\alpha F}$ is Tafel slope, where α is the charge transfer coefficient.
- i_0 is Exchange current density.
- i_{cell} is Actual current density.

This voltage drop becomes significant at low current densities and is critical for determining the fuel cell's performance at low loads.

4. Ohmic Losses

Ohmic losses result from resistance to proton transport through the membrane and electron flow through the electrodes and interconnects. The total ohmic voltage drop is:

$$V_{ohm} = i_{cell} \cdot R_{ohm} = i_{cell} \cdot \frac{t_{membrane}}{\sigma} \quad (23)$$

where:

- $t_{membrane}$ is the membrane thickness.
- σ is Ionic conductivity of the membrane, which depends on water content (humidity) and temperature.

Maintaining proper membrane hydration is essential to minimize ohmic losses and sustain performance.

5. Mass Transport (Concentration) Losses

At high current densities, reactants may not reach the reaction sites quickly enough, leading to concentration losses:

$$V_{conc} = -\frac{RT}{2F} \ln\left(1 - \frac{i_{cell}}{i_L}\right) \quad (24)$$

where:

- i_L Limiting current density, beyond which oxygen starvation occurs.
- This term increases rapidly near the limiting current and reflects diffusion constraints.

6. Net Cell Voltage

Combining the above effects, the actual cell voltage becomes:

$$V_{ohm} = V_{Nernst} - V_{act} - V_{ohm} - V_{conc} \quad (25)$$

This net voltage reflects the usable output after accounting for all internal losses and inefficiencies.

7. Fuel Consumption and Water Generation

The amount of reactants consumed and products generated is linked to the current by Faraday's law:

$$\dot{n}_{H_2} = \frac{i_{cell} \cdot A \cdot N_{cell} \cdot M_{H_2}}{2F} \quad (26)$$

$$\dot{n}_{O_2} = \frac{i_{cell} \cdot A \cdot N_{cell} \cdot M_{O_2}}{4F} \quad (27)$$

$$\dot{n}_{H_2O} = \frac{i_{cell} \cdot A \cdot N_{cell} \cdot M_{H_2O}}{2F} \quad (29)$$

where:

- \dot{n} is Mass flow rate.
- A is Cell active area.
- N_{cell} is Number of cells in the stack.
- M_i is Molar mass of species i .

These expressions are crucial for balancing the reactant and product streams in system-level integration.

8. Efficiency Calculation

The electrical efficiency is expressed with respect to the higher heating value (HHV) or lower heating value (LHV) of hydrogen:

$$\eta_{HHV} = \frac{V_{Cell}}{HHV_{H_2}/(2F)} , \eta_{LHV} = \frac{V_{Cell}}{LHV_{H_2}/(2F)} \quad (30)$$

These metrics are useful for evaluating the thermodynamic performance of the fuel cell under practical operating conditions.

This comprehensive electrochemical framework enables accurate modeling of PEM fuel cell behavior, considering internal losses and physical interactions. It forms the foundation for further analysis, optimization, and real-time control strategies, especially when coupled with advanced digital twin models.

C. Modelling Of The Proposed System:

In this study, MATLAB Simulink was utilized to design a comprehensive and advanced fuel cell model. The system architecture is structured into two main compartments, separated by a proton exchange membrane: the anode and cathode sides.

On the anode side, the design incorporates gas flow channels combined with a humidifier to maintain optimal hydration of the fuel cell membrane, ensuring maximum performance under conditions of 100% relative humidity. To improve efficiency, a recirculation system was employed, complemented by an exhaust mechanism to isolate nitrogen from the recirculated hydrogen. The hydrogen supply is sourced from a dedicated storage tank, ensuring a steady and reliable fuel feed. Similarly, the cathode side is equipped with gas flow channels and a humidifier for precise moisture regulation. An exhaust mechanism is included to remove byproducts effectively. Atmospheric oxygen is utilized as the primary oxidant, simplifying the oxygen supply system.

To maintain consistent operating conditions, a cooling system has been integrated to regulate the temperature of the fuel cell. This detailed system model replicates the functionality of a real-world fuel cell, offering a robust framework for simulation, performance analysis, and optimization.

The modeled fuel cell was represented schematically as shown in **Figure 3-22** .

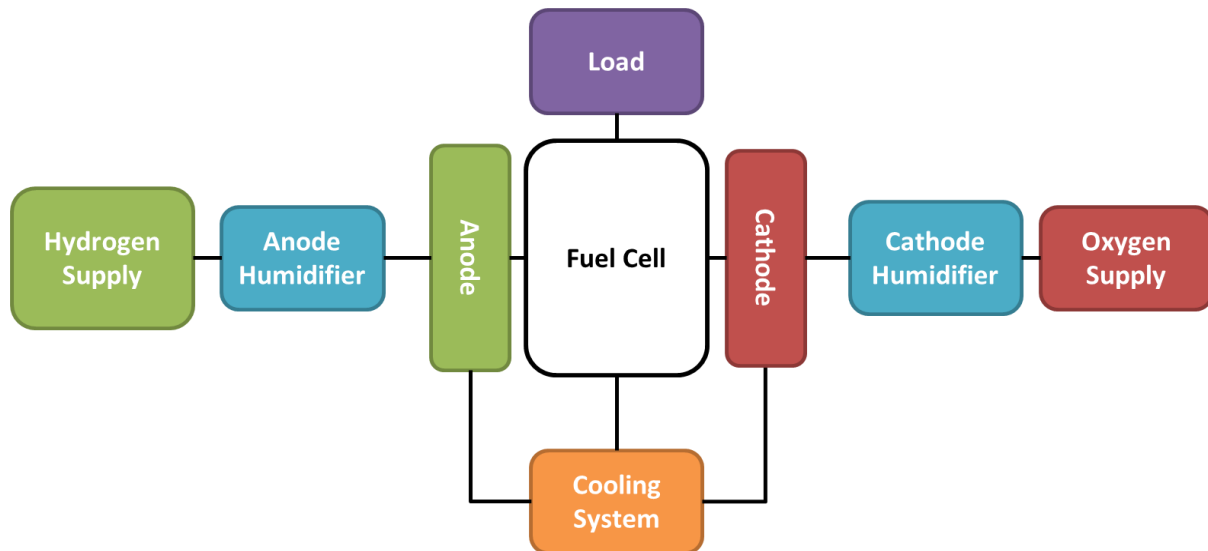

Figure 3-22 Advanced Fuel Cell MATLAB Model

The **Table 3-5** presents a set of values used in the simulation, derived from scientific and industrial references to ensure reliable results under realistic operating conditions

Table 3-5 Physical Parameters Used for the Fuel Cell

Parameter	Value	Unit
Number of cells in stack	400	-
Active area per cell	280	cm ²
Membrane thickness	125	µm
Exchange current density	8e-5	A/cm ²
Limiting current density	1.4	A/cm ²
Charge transfer coefficient	0.5	-
Water vapor diffusivity in GDL	0.07	cm ² /s
Membrane permeability	1.58e-14	cm ²
Membrane density	2000	kg/m ³
Equivalent weight of dry membrane	1.1	kg/mol

While the Figure 3-23 shows Advanced Fuel Cell Model in MATLAB/Simulink.

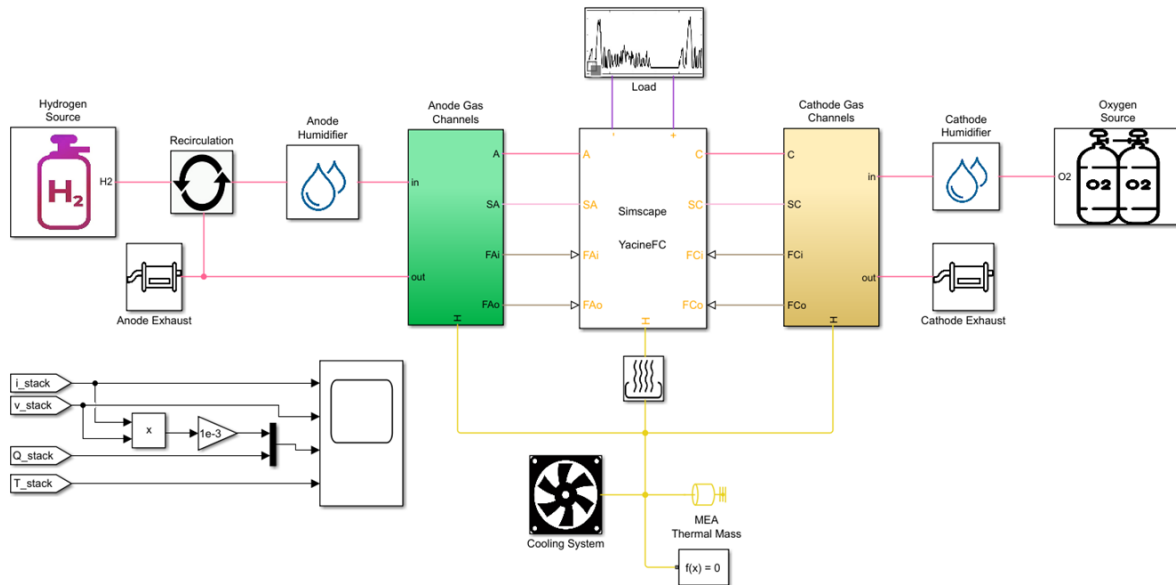

Figure 3-23 Advanced Fuel Cell MATLAB Model

D. Simulation Process:

Three operational scenarios were analyzed:

1. **Drive Cycle Profile:** Simulates the dynamic load changes in vehicle applications.
2. **Step Current Profile:** Evaluates fuel cell response to sudden load changes.
3. **Ramp Current Profile:** Assesses performance under gradual load increases.

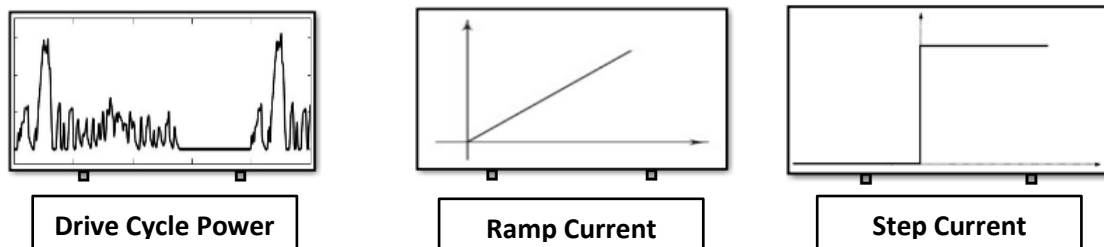

Figure 3-24 Load Profiles

E. Simulation Results:

The simulation results illustrate the current-voltage (i-v) characteristics and power output behavior of the fuel cell stack. As the current increases, the voltage initially drops due to activation losses at the electrodes, followed by a more gradual decrease caused by Ohmic resistance. At maximum current levels, the voltage exhibits a steep decline, attributed to gas transport limitations. The corresponding power output curves show an initial rise to a peak, followed by a decline due to increased losses at higher currents.

The total electrical power output includes contributions from the fuel cell stack while accounting for the energy consumed by auxiliary systems such as the cathode air compressor and coolant pump, which are essential for maintaining operational stability and efficiency. Consequently, the net power output is slightly lower than the gross stack power, with efficiency losses further compounded when compressor performance is considered. The fuel cell stack's maximum power output is recorded at 110 kW, while the system's excess heat, illustrated in the graphs, requires dissipation through a cooling system to maintain thermal stability.

Thermal efficiency, a measure of the hydrogen fuel's energy converted into electrical work, achieves around 60% under normal operating conditions. This value decreases to approximately 45% at maximum current due to internal losses, deviating from the theoretical maximum efficiency of 83% for PEM fuel cells.

Reactant utilization quantifies the consumption of hydrogen and oxygen within the stack. Although increased utilization improves resource efficiency, it reduces reactant concentrations, leading to voltage drops. Unused oxygen is expelled, while excess hydrogen is recirculated to the anode to minimize waste. Periodic purging of the hydrogen stream is necessary to remove accumulated impurities, ensuring optimal system performance.

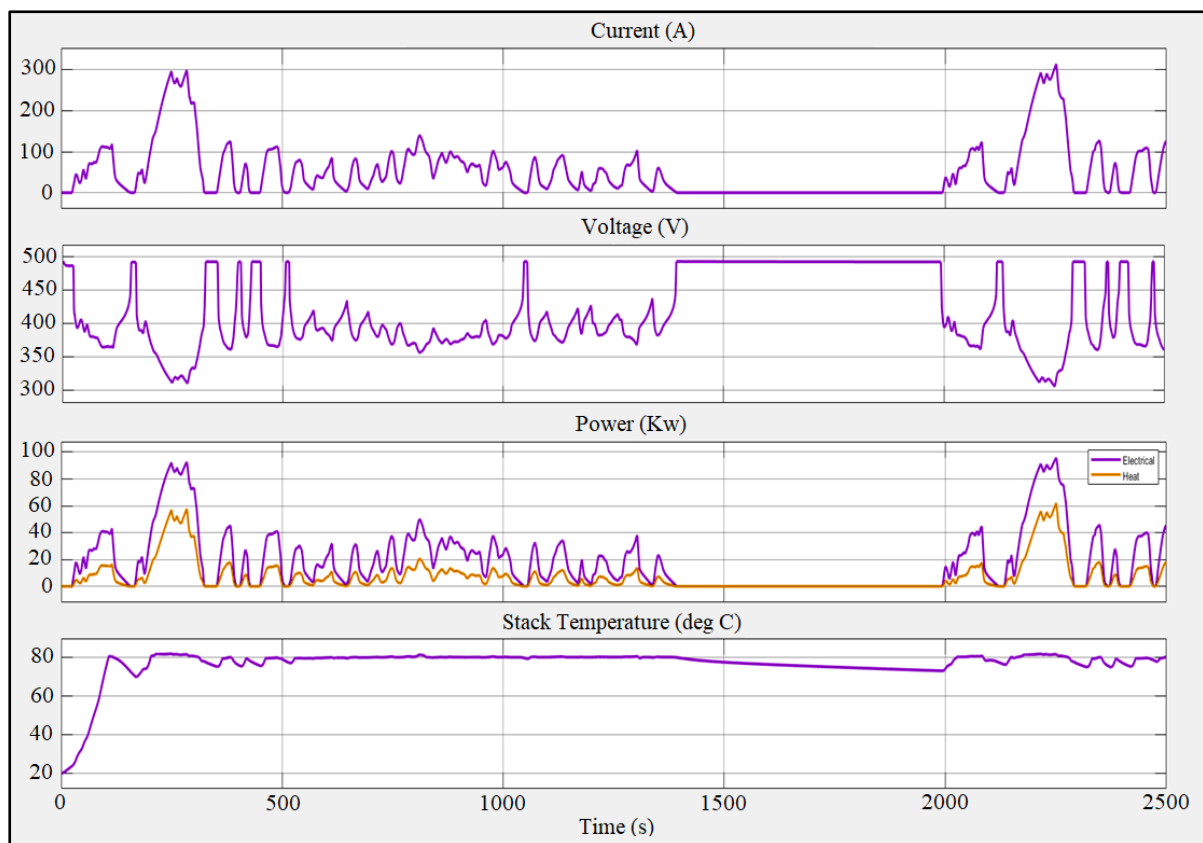

Figure 3-25 Drive Cycle Profile graphs

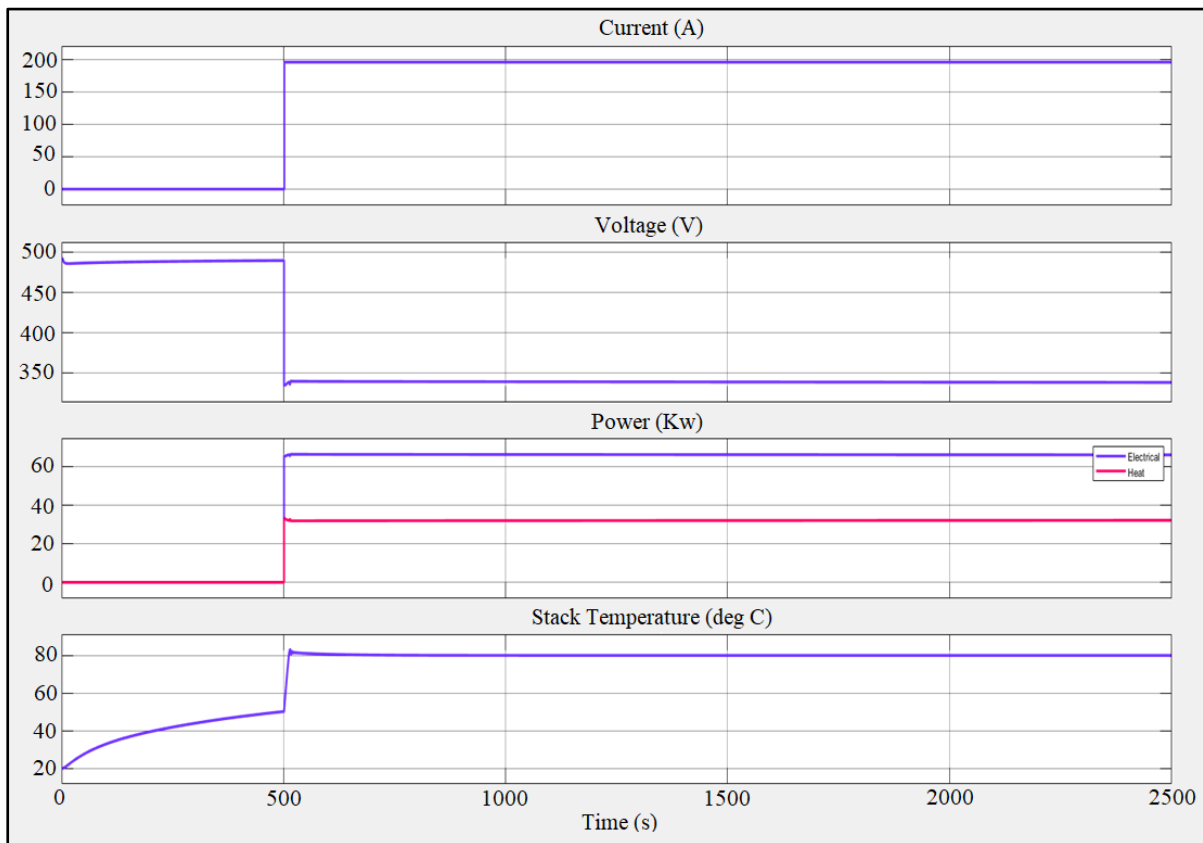

Figure 3-26 Step Profile graphs

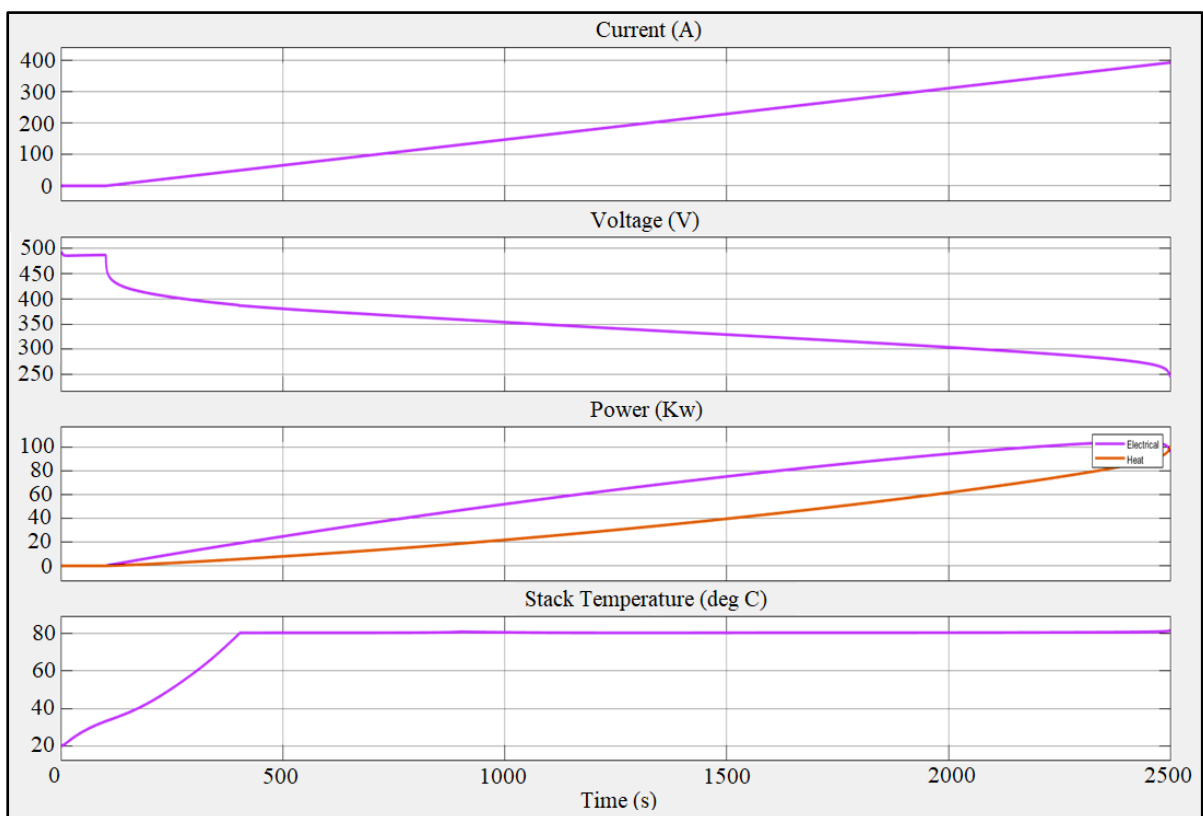

Figure 3-27 Ramp Profile graphs

3.3.3 Scientific Insights and Technological Implications

A. Efficiency Enhancement:

Digital twins enable precise control over operational parameters. For instance, optimizing **humidity levels** and **temperature control** can significantly reduce **Ohmic and activation losses**. Moreover, simulations help determine the optimal operating point to maximize power output while minimizing fuel consumption.

B. Error Detection and Diagnosis:

By continuously comparing real-time data with the digital model's predictions, deviations can be quickly identified. This capability is critical for detecting issues like **catalyst degradation** or **membrane fouling**, which are common in PEMFCs.

C. Predictive Maintenance:

Advanced analytics forecast maintenance needs based on historical data and operational trends, reducing downtime and maintenance costs. For example, **hydrogen purity sensors** and **voltage drift analysis** can predict membrane wear or gas leakage before failure occurs.

3.3.4 System Modeling and Load Analysis

In constructing the digital twin, a detailed simulation framework was developed:

- **Advanced Fuel Cell Simulation:** Representing the full fuel cell stack, this model integrates both electrochemical processes and thermal management strategies.
- **Electrochemical Reactions:** Core processes include hydrogen oxidation at the anode and oxygen reduction at the cathode, with platinum catalysts facilitating both reactions.
- **Load Profiles:** The system was tested under multiple load conditions to evaluate dynamic responses. These profiles included:
 - **Drive Cycle Profile:** Simulates varying loads encountered in real-world automotive applications.
 - **Step Current Profile:** Measures stability and transient response to sudden changes.
 - **Ramp Current Profile:** Analyzes gradual load increases and peak performance scenarios.

3.3.5 Future Prospects and Research Directions

- **Integration with IoT and AI:**

Combining digital twins with **Internet of Things (IoT)** technologies enhances data acquisition and real-time monitoring. **Artificial Intelligence (AI)** algorithms can analyze complex datasets to predict failures and optimize performance.

- **Validation and Benchmarking:**

Future work involves validating the digital twin against real-world PEMFCs to refine accuracy and reliability. Comparative studies will establish benchmarks for fuel cell performance, facilitating standardization and widespread adoption.

Digital twins offer a powerful tool for enhancing fuel cell efficiency and reliability. By creating a dynamic virtual model, they enable real-time monitoring, fault detection, and predictive maintenance. The case study using **MATLAB Simscape** demonstrates significant potential for optimizing **PEMFC** performance, highlighting the transformative impact of digital twins in sustainable energy systems.

3.4 Integrating Storage Systems with Photovoltaic Grids

Energy storage integration is essential for addressing the intermittency of solar power and ensuring grid stability. By coupling PV systems with storage technologies, excess energy can be stored during periods of high production and discharged when demand exceeds supply. This integration enhances energy reliability and reduces dependency on fossil-fuel-based backup systems.

3.4.1 Key Storage Technologies

- **Battery Storage:** Lithium-ion batteries dominate the market due to their high energy density, fast response time, and declining costs. However, issues such as limited lifespan and thermal management challenges remain. Innovations in solid-state batteries and recycling technologies are addressing these concerns.
- **Hydrogen Storage:** Hydrogen offers a promising long-term storage solution for excess solar energy. Through electrolysis, surplus electricity converts water into hydrogen, which can be stored and later reconverted into electricity using fuel cells. Hydrogen

storage systems have higher energy density and longer storage durations compared to batteries, making them suitable for large-scale applications.

- **Thermal Energy Storage (TES):** TES systems store excess heat generated by PV systems, which can be used directly or converted back into electricity. This method is particularly beneficial in regions with high solar irradiance and industrial heat demand.

3.4.2 Techno-Economic and Environmental Considerations

Integrating storage systems with PV grids involves significant initial investments but offers long-term benefits such as reduced operational costs, enhanced grid stability, and lower carbon emissions. A techno-economic analysis suggests that hybrid storage solutions combining batteries and hydrogen can optimize cost-efficiency and performance. Additionally, life-cycle assessments indicate that storage integration can reduce the carbon footprint of PV systems by up to 30%.

3.4.3 Theoretical Foundations and Principles

- **Grid-Connected PV Systems:**

These systems convert solar energy into electricity, feeding it directly into the electrical grid. However, the **intermittent nature of solar radiation** poses challenges for consistent power supply, especially during cloudy periods or at night.

- **Role of Battery Storage:**

Battery storage systems mitigate these issues by storing excess energy generated during peak sunlight hours and discharging it when solar production is insufficient. This capability ensures a more stable and continuous power supply, reducing grid reliance and enhancing system efficiency.

3.4.4 System Design and Components

The proposed system, analyzed in **HOMER**, consists of three main components: the **PV array**, **battery storage unit**, and **power electronic converters (Figure 3-28)**.

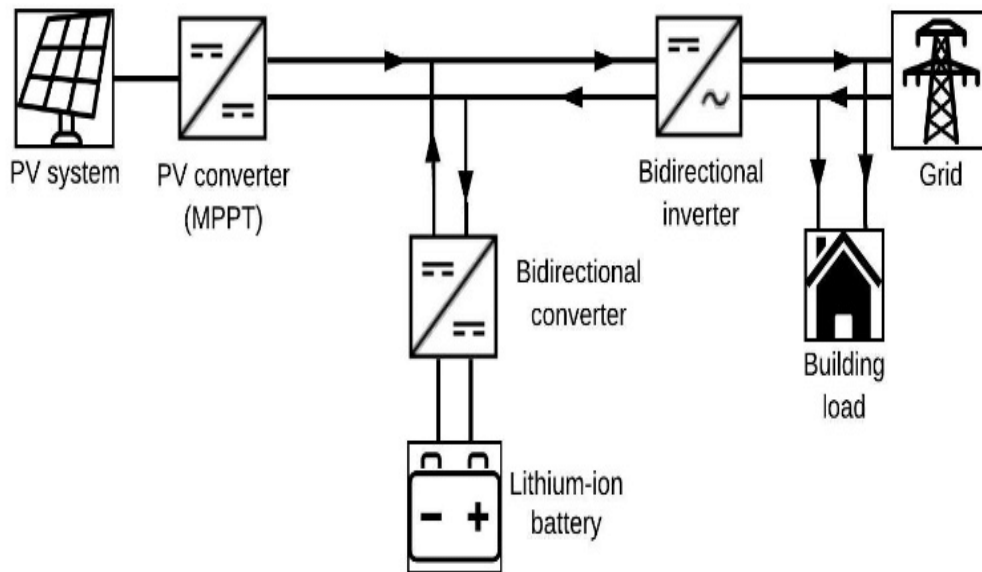

Figure 3-28 Illustration of the designed system

Specifications:

- **PV Panels:** Capital cost of \$350 per kW, 22% efficiency, and a 25-year lifespan (Table 3-6).

<i>Table 3-6 Specifications of PV panels</i>	
Capital cost per kW	350 \$ (47250 DA)
Replacement cost per kW	350 \$ (47250 DA)
O-M cost per kW	10 \$ (1350 DA)
Lifetime(years)	25
Efficiency	22 %

- **Battery Storage:** Capital cost of \$135 per kW, 80% efficiency, and a 7-year lifespan (Table 3-7).

Table 3-7 Specifications of battery storage	
Capital cost per kW	135 \$ (20250 DA)
Replacement cost per kW	135 \$ (20250 DA)
O-M cost per kW	10 \$ (1350 DA)
Lifetime (years)	7
Efficiency	80 %

- **Converters:** Capital cost of \$165 per kW and 95% efficiency, with a lifespan of 25 years (Table 3-8).

Capital cost per kW	165 \$ (22270 DA)
Replacement cost per kW	165 \$ (22270 DA)
O-M cost per kW	10 \$ (1350 DA)
Lifetime (years)	25
Efficiency	95 %

3.4.5 Simulation and Optimization using HOMER Pro

A. Simulation Framework:

The **HOMER (Hybrid Optimization Model for Electric Renewables)** software performs hourly simulations to evaluate various system configurations. It optimizes these configurations based on criteria such as **Total Net Present Cost** and **Levelized Cost of Electricity (LCOE)**.

B. System Description:

This study presents an integrated energy system featuring a grid-connected photovoltaic (PV) station designed to supply electricity to a small city of 120 households, meeting a total daily energy demand of 1,800 kilowatt-hours. To maximize operational efficiency, the system incorporates battery storage for excess energy generated during peak sunlight hours. The research focuses on evaluating the system's performance and efficiency across varying conditions. The electric load profile indicates peak consumption between 12 p.m. and 1 p.m.

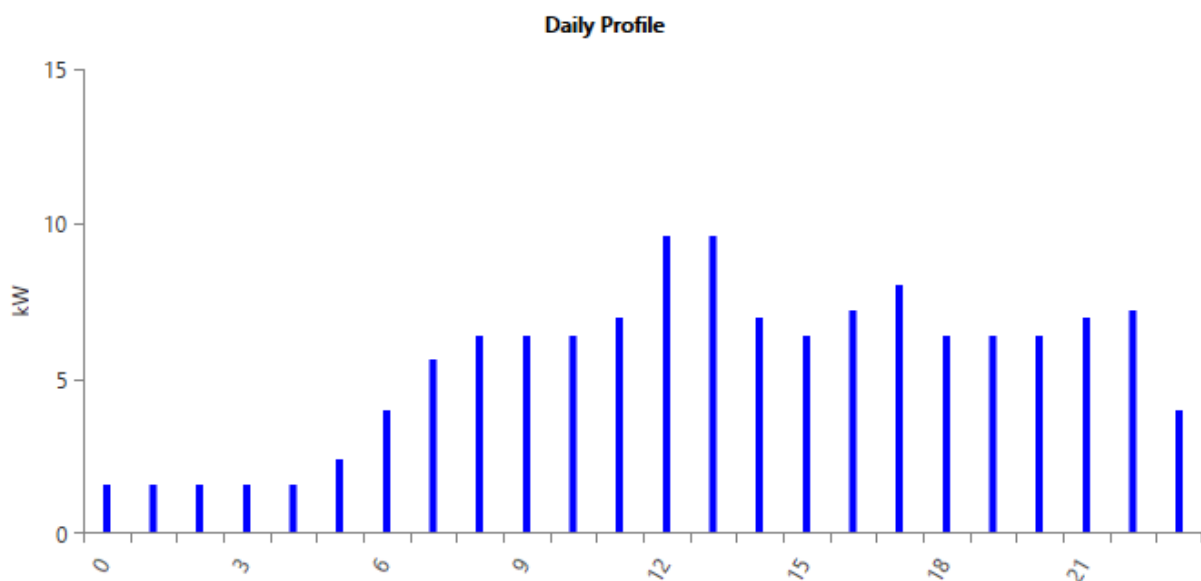

Figure 3-29 Electricity demand profile

C. Renewable Energy Potential of the Site:

The renewable energy potential of the Bechar region in Algeria, characterized by abundant sunlight, was assessed using solar irradiance data input into HOMER software. The photovoltaic (PV) energy output is influenced by solar radiation and temperature, both of which were analyzed to determine the feasibility of power generation. Solar radiation exhibits fluctuations, with a daily average minimum of 5.3 kWh/m² and peak levels observed during May, June, and July. Additionally, the average daily temperature reinforces the region's suitability for efficient solar energy production.

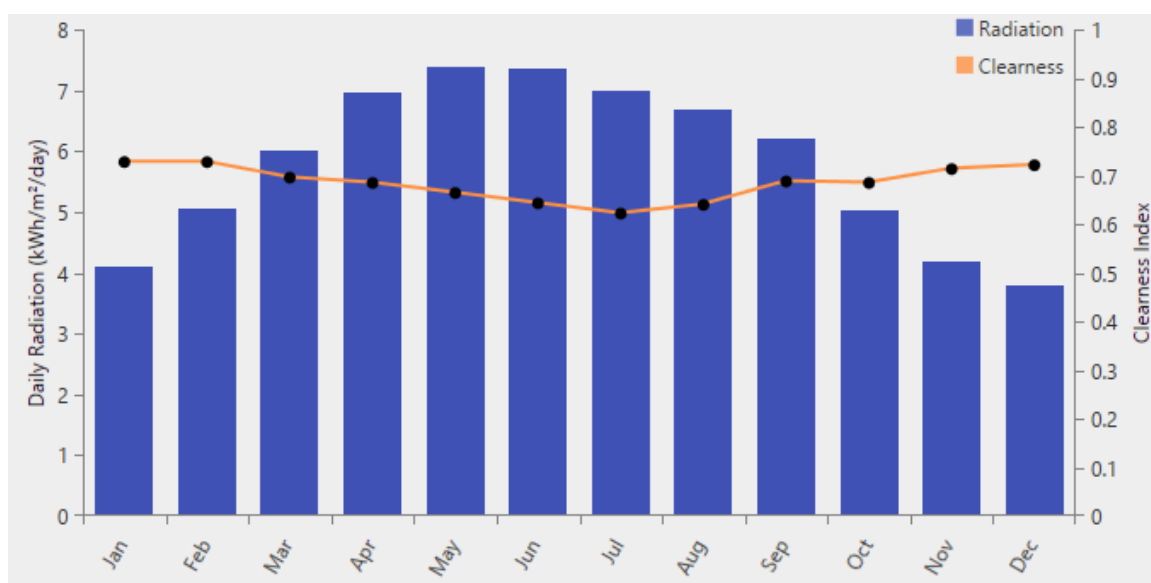

Figure 3-30 Electricity demand profile

3.4.6 SIMULATION RESULTS:

A. Case 1: Electricity Selling Enabled

In this scenario, the electricity purchase and selling price were set at 0.4 \$ (54 DA) per kWh to establish a balanced cost framework.

The simulation yielded surprising results, demonstrating that the system incorporating a battery significantly outperformed the grid-only configuration in terms of overall efficiency and reliability. The integration of a battery enhanced energy management by effectively storing surplus energy generated during periods of low demand and providing it during peak consumption times. This not only reduced reliance on the grid but also minimized energy losses, resulting in a more stable and sustainable energy supply. These findings underscore the

advantages of hybrid systems, particularly in optimizing energy use and improving the resilience of power infrastructure.

				Cost			
				NPC (\$)	COE (\$)	Operating cost (\$/yr)	Initial capital (\$)
				-\$14.1M	-\$0.217	-\$1.33M	\$3.11M
				-\$12.9M	-\$0.257	-\$1.15M	\$1.91M
				\$3.40M	\$0.400	\$262,800	\$0.00
				\$3.40M	\$0.401	\$263,177	\$2,436

Figure 3-31 Homer Simulation results

A detailed analysis of the comparative performance curve between the battery-based system and the baseline configuration, supported by comprehensive data in the accompanying tables, highlights the exceptional economic advantages of the battery-integrated approach. This system demonstrates its capacity to achieve a return on investment (ROI) within an impressively short period of 1.7 years. Moreover, the financial return is projected at 14.1 million dollars, underscoring the significant profitability of this configuration.

The analysis also reveals a highly competitive Levelized Cost of Electricity (LCOE) of - \$0.217 (29 DA), which not only signals cost savings but also suggests a net financial benefit from the system’s operation. These findings emphasize the dual advantages of the battery-based system: its ability to provide sustainable energy solutions while offering substantial financial returns. This analysis positions the battery-integrated system as a forward-thinking investment, aligning economic feasibility with environmental responsibility for long-term energy strategy optimization.

Photovoltaic (PV) with battery integration, grid-connected PV without batteries, and a grid-only system reveals that the battery-integrated system excels in minimizing environmental impact. The inclusion of batteries significantly enhances the overall system efficiency by optimizing energy usage, particularly during peak and off-peak periods, and reducing dependency on grid power derived from fossil fuels.

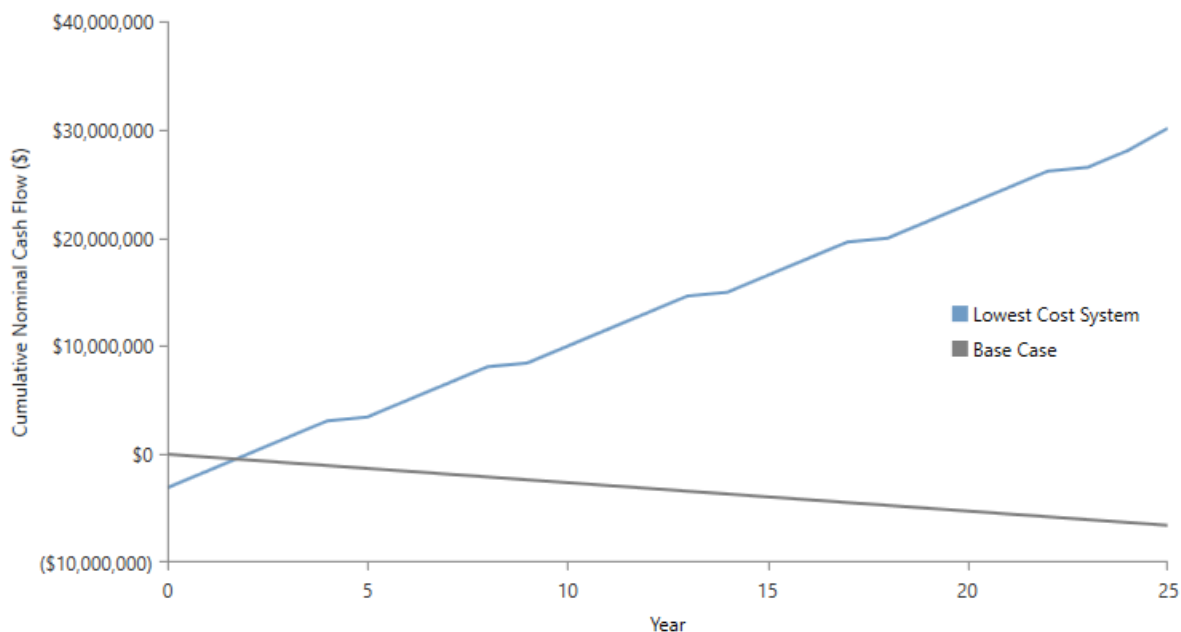

Figure 3-32 Base case comparison and lowest-cost system

This configuration demonstrates a marked reduction in greenhouse gas emissions, aligning with global sustainability goals and emphasizing its potential as an environmentally responsible solution. By facilitating the storage and utilization of excess renewable energy during high-production periods, batteries ensure that clean energy is maximized and waste is minimized.

Quantity	Value	Units	Quantity	Value	Units	Quantity	Value	Units
Carbon Dioxide	85,677	kg/yr	Carbon Dioxide	148,563	kg/yr	Carbon Dioxide	415,224	kg/yr
Carbon Monoxide	0	kg/yr	Carbon Monoxide	0	kg/yr	Carbon Monoxide	0	kg/yr
Unburned Hydrocarbons	0	kg/yr	Unburned Hydrocarbons	0	kg/yr	Unburned Hydrocarbons	0	kg/yr
Particulate Matter	0	kg/yr	Particulate Matter	0	kg/yr	Particulate Matter	0	kg/yr
Sulfur Dioxide	371	kg/yr	Sulfur Dioxide	644	kg/yr	Sulfur Dioxide	1,800	kg/yr
Nitrogen Oxides	182	kg/yr	Nitrogen Oxides	315	kg/yr	Nitrogen Oxides	880	kg/yr

PV/Battery/Grid system	PV/Grid system	Grid-only system
-------------------------------	-----------------------	-------------------------

Figure 3-33 Three Systems Emissions

The system produces an electricity output that far exceeds the demand from the grid. This surplus generation underscores the system's capability to not only meet but also surpass local energy requirements, creating opportunities for diverse applications of the excess energy. For instance, the additional electricity can be stored in batteries for later use, exported to external grids, or redirected to power auxiliary systems such as green hydrogen production facilities.

This overproduction aligns with a sustainable energy model, ensuring that energy availability remains robust even during periods of fluctuating grid demand. Additionally, it demonstrates the potential for such systems to serve as reliable sources for supporting future energy needs, including integration with renewable energy-driven industries and enhancing energy security.

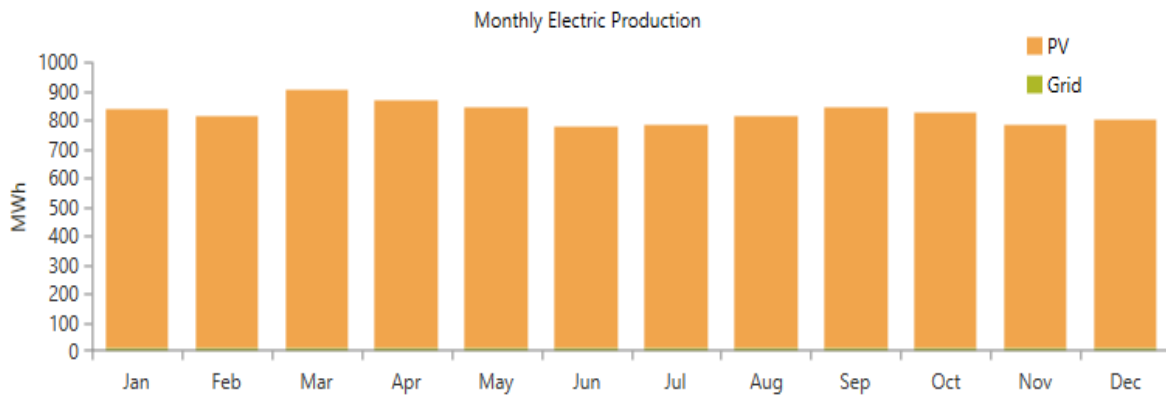

Figure 3-34 Electrical performance of the lowest-cost system

B. Case 2: Electricity Selling Disabled

In the second scenario, the analysis assumes a zero-electricity selling value, meaning surplus electricity cannot be sold to the grid. Despite this constraint, the results unveiled an intriguing and noteworthy finding: the battery-integrated system demonstrated superior performance compared to the grid-only configuration. This advanced system achieved a Levelized Cost of Electricity (LCOE) of 0.26 \$ (35 DA) per kilowatt-hour, underscoring its cost-effectiveness and operational efficiency even in scenarios where revenue from electricity sales is nonexistent.

This outcome highlights the inherent advantages of incorporating battery storage, which not only optimizes energy utilization by storing excess electricity for later use but also ensures stability and reliability in power supply. Such resilience is particularly crucial for renewable energy systems, where intermittency can pose challenges. The findings also emphasize the potential of battery-powered systems to drive economic and environmental benefits, making them a strategic choice for sustainable energy solutions even under restrictive financial conditions.

				Cost			
				NPC (\$)	COE (\$)	Operating cost (\$/yr)	Initial capital (\$)
				\$3.32M	\$0.260	\$105,237	\$1.96M
				\$3.40M	\$0.400	\$262,800	\$0.00
				\$3.40M	\$0.401	\$263,177	\$2,436
				\$3.64M	\$0.273	\$144,124	\$1.78M

Figure 3-35 Insights from HOMER simulation results

Through an in-depth analysis of the comparative performance curve between the battery-equipped system and the baseline configuration, supported by detailed tabular data, it has been determined that the battery-integrated system achieves a return on investment (ROI) within 13 years. This evaluation highlights the system’s long-term economic viability and resilience in financial terms.

Additionally, the system outperforms the conventional grid-based setup in terms of environmental impact. By significantly reducing the emission of harmful greenhouse gases, the battery-enhanced system not only proves to be economically efficient but also aligns with global goals of environmental sustainability. These dual benefits make it a compelling choice for advancing cleaner energy initiatives while ensuring cost-effectiveness over the system's operational lifespan.

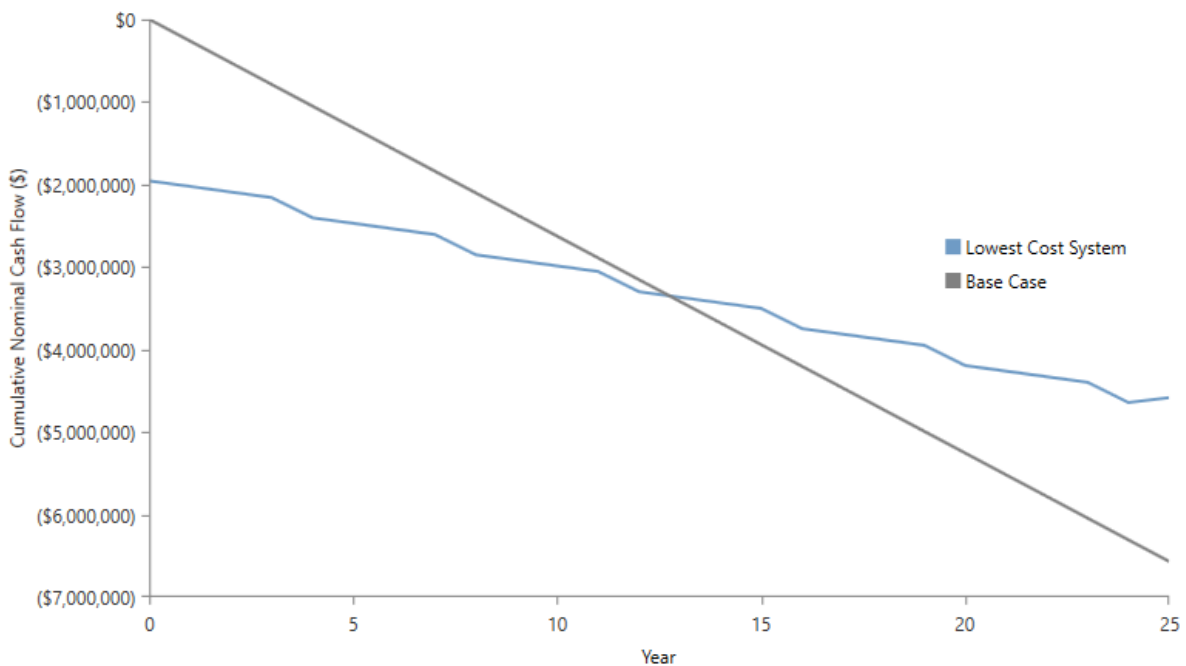

Figure 3-36 Comparison of PV/Battery/Grid system with the base case (Grid)

Quantity	Value	Units
Carbon Dioxide	7,129	kg/yr
Carbon Monoxide	0	kg/yr
Unburned Hydrocarbons	0	kg/yr
Particulate Matter	0	kg/yr
Sulfur Dioxide	30.9	kg/yr
Nitrogen Oxides	15.1	kg/yr

Figure 3-37 Detailed emissions of PV/B/Grid system

3.5 Conclusion:

In summary, this chapter has detailed the advanced technologies and integrated systems that enable the efficient conversion of renewable energy into green hydrogen. The discussion on photovoltaic systems, along with innovative control and modeling strategies, underscores the potential to overcome technical challenges and enhance system performance. Moreover, the review of various electrolysis methods and sustainable water sourcing approaches has provided critical insights into scalable hydrogen production, while advanced modeling and digital twin technologies illustrate how theoretical frameworks can be effectively translated into practical applications.

The exploration of integrated storage solutions further emphasizes the importance of ensuring system stability and addressing the intermittency of renewable sources. Together, these components form the technical backbone of a robust green hydrogen production system.

This comprehensive examination not only reinforces the role of cutting-edge technology in driving sustainable energy transitions but also establishes a solid foundation for the broader system integration and strategic analysis discussed in subsequent chapters. As the narrative progresses, the focus will shift toward aligning these technological advancements with economic and environmental objectives, paving the way for a holistic approach to sustainable energy development.

Chapter 4:
**Advancing Green Hydrogen
Production in Algeria**

Chapter 4 : Advancing Green Hydrogen Production in Algeria

Green hydrogen, produced through renewable energy sources, holds immense potential for reducing greenhouse gas emissions and improving global energy systems. In Algeria, green hydrogen production serves not only as a solution to the increasing demand for clean energy but also as a means to leverage the country's vast renewable energy resources. This chapter provides a deep analysis of the technological, economic, and environmental aspects of green hydrogen production in Algeria.

Using simulation tools like HOMER Pro and comparative analyses of hydrogen production across diverse regions, this chapter examines the efficiency and cost-effectiveness of green hydrogen projects. The findings underscore the critical role of advanced simulation, strategic resource management, and innovative production methods in driving Algeria's transition to a hydrogen-based economy.

4.1 Summary of Previous Research on Green Hydrogen in Algeria

Despite being a nascent field, several pivotal studies have assessed Algeria's potential for green hydrogen production. Most research focuses on leveraging the country's abundant renewable energy resources, particularly solar and wind, while addressing geographical and technical variability. However, significant gaps remain in addressing water sourcing, hydrogen storage, and the impact of high ambient temperatures in desert regions.

4.1.1 Hydrogen Production from Photovoltaics (PV)

A. Mraoui and **S. Menia** conducted detailed simulations to evaluate hydrogen production potential using PV systems. Their findings highlighted theoretical production values ranging from **0.10 to 0.14 Nm³/m²/year**, with high potentials in the arid southeast and north-eastern lowlands. In the northwest, where population density is higher, hydrogen production reached **0.13 Nm³/m²/day**, indicating regional variability in PV efficiency. [77]

4.1.2 Wind Energy Integration

In Adrar province, **Djilali Masoudi et al.** utilized an Analytical Hierarchy Process (AHP) integrated with GIS to pinpoint optimal locations for wind-powered hydrogen fueling stations. Their study demonstrated that nearly all of Adrar is viable for wind energy integration. Out of 15 assessed stations, four were selected for upgrades, three of which are in high-suitability zones. [78]

4.1.3 Hybrid Renewable Energy Systems

Gougui et al. explored hydrogen production through a PV-electrolyzer system in Ouargla, showcasing the region's suitability for standalone renewable systems [79]. Similarly, **Mouloud Baik** investigated a hybrid power station in Gant that integrates solar and wind energy to enhance efficiency and mitigate intermittency. [80]

4.1.4 Concentrated Solar Power (CSP) and Hydrogen Production

Lemya Bentoumi evaluated CSP systems combined with SRC and ORC cycles in Illizi and Tindouf. Illizi showed the highest power output, with efficiency reaching **24.9%** and hydrogen production rates peaking at **219 Nm³** using SOE electrolyzers. Other electrolyzers like PEME and AE yielded **185 Nm³** and **148 Nm³**, respectively, demonstrating the feasibility of CSP integration in desert areas. [81]

4.1.5 Geographical Resource Mapping

Samia Rahmouni et al. conducted a comprehensive mapping of Algeria's hydrogen production potential. Using solar and wind energy, they identified Laghouat and Adrar as key wind energy sites, with energy outputs of **1074.88 GWh/km²/year** and **915.09 GWh/km²/year**, producing **18,447.6 tons/km²/year** and **15,705.3 tons/km²/year** of hydrogen, respectively. Solar energy potentials were highest in Tamanrasset and El Tarf, yielding **6,327.19 tons/km²/year** and **4,437.14 tons/km²/year**, respectively. [24]

4.2 4.2. Critical Gaps and Challenges

While these studies have provided valuable insights into the energy potential of Algeria's renewable resources, they often neglect critical aspects:

- **Water Resource Management:** Most studies fail to address sustainable water sourcing for hydrogen production, particularly in desert regions. Samia Rahmouni's suggestion of groundwater use raises concerns about the depletion of non-renewable reserves.
- **Hydrogen Storage and Transportation:** The effects of high desert temperatures on hydrogen storage and transport logistics remain unexplored.
- **Comprehensive Frameworks:** Few studies integrate geographical, social, and economic considerations with technical assessments, leaving gaps in holistic project planning.

4.3 Relevance to Current Study

This chapter builds on previous research by integrating renewable energy analysis with innovative water management strategies and addressing logistical challenges like hydrogen storage and transport. By adopting a holistic approach, the study aims to position Algeria as a global leader in green hydrogen production while ensuring environmental sustainability and economic feasibility.

4.4 Simulation Tools and Methodologies

4.4.1 HOMER Pro Overview and Capabilities

HOMER Pro is a leading simulation platform for modeling and optimizing renewable energy systems. Its ability to integrate various energy sources, storage options, and end-user demands makes it a versatile tool for assessing techno-economic viability. The software is particularly effective in identifying optimal configurations and performing sensitivity analyses to evaluate the impact of varying parameters such as solar irradiance, water availability, and operational costs on hydrogen production.

In the context of Algeria, HOMER Pro was pivotal in analyzing PV-based systems for green hydrogen production. By simulating energy outputs under different climatic and geographical conditions, the software enabled the comparison of regions in terms of efficiency and cost-effectiveness.

4.4.2 Employed Methodology

The study begins by introducing the development of a 20-megawatt solar power plant in the Ain Salah region of Algeria. This facility is already operational, supplying electricity to nearly 100 households. On average, it produces around 1,400 kilowatt-hours of electricity daily, ensuring a steady and sustainable energy supply for the local community. Excess electricity generated during peak sunlight hours is diverted to an electrolyzer, facilitating the production of green hydrogen. The hydrogen is subsequently stored in high-pressure tanks, serving as a backup energy source during periods of reduced solar availability. This integrated approach enhances energy reliability while reducing dependence on fossil fuels.

To maximize resource utilization, the system employs a real-time energy management strategy. When solar energy production is high, priority is given to meeting local electricity demand, with any surplus being directed to hydrogen production via the electrolyzer. The HOMER software was used to model and optimize the system's performance, ensuring seamless

integration of solar energy, hydrogen generation, and storage solutions. This methodology contributes to the establishment of a sustainable and resilient energy infrastructure tailored to Algeria's climatic conditions.

The analysis utilizes a generic electrolyzer model available in HOMER Pro software, allowing for flexible assessments across different operational scenarios. Although a specific electrolyzer type was not predefined, the model is designed to reflect typical performance characteristics of commercial electrolyzers, with efficiency levels ranging from 65% to 70%. This approach ensures broad applicability to widely used technologies, such as Alkaline and Proton Exchange Membrane (PEM) electrolyzers.

A. Primary Energy System Configuration

To ensure uninterrupted energy supply, a fuel cell system has been employed, utilizing stored hydrogen to produce electricity during periods of insufficient sunlight, such as nighttime or overcast conditions. This strategy effectively mitigates the intermittent nature of solar energy, providing a consistent and reliable power output. **Figure 4-1** depicts the configuration of the energy system, which integrates photovoltaic panels, an electrolyzer, and a fuel cell.

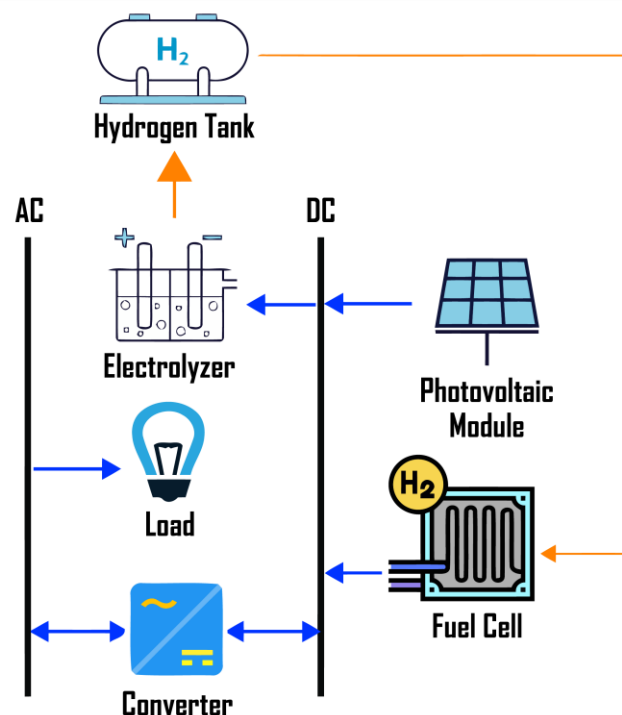

Figure 4-1 Diagram of a PV-Electrolyzer-Fuel Cell Power System

The detailed specifications and components of the system are summarized in **Table 4-1**.

Table 4-1 System specifications

Power Component	Specification
PV	20 MW
Electrolyser	21 MW
FC	1 MW
Converter	160 KW

B. Supplementary Energy Solutions

As additional solutions, we suggest implementing advanced battery systems to store excess energy generated during peak sunlight hours **Figure 4-2**, which can then be used to offset energy shortages during periods of low sunlight. This would enable us to preserve the produced hydrogen for other applications. Furthermore, we consider integrating a grid-connected system, which can provide an additional source of energy during extended periods of insufficient sunlight, ensuring that energy demands are consistently met without over-reliance on any single method.

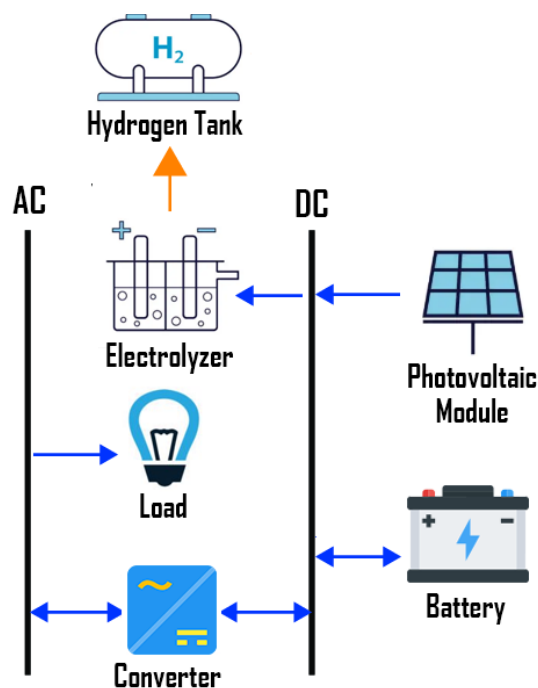

Figure 4-2 Diagram of a PV-Electrolyzer- Battery Power System

C. Geographic and Climatic Application

The proposed solar power and hydrogen production system is designed for deployment beyond a single site. Its application is extended across several regions in Algeria, each with

distinct climatic characteristics. Specifically, areas such as Tamanrasset, Bechar, Adrar, Skikda, M'Sila, and Tlemcen have been selected to offer a balanced comparison between desert and northern environments, facilitating a detailed evaluation of their individual potentials for green hydrogen production.

Moreover, an international comparative study was carried out using benchmarks from Germany, Australia, and Mauritania to position Algeria's capabilities within the global hydrogen market. Germany and Australia were chosen for their leading roles in green hydrogen initiatives, while Mauritania's climate and solar resource profile closely resemble Algeria's. This comparison highlights Algeria's competitive advantage in solar energy productivity and emphasizes the feasibility of achieving sustainable hydrogen production, particularly in its northern regions.

By examining these varied locations, the study aims to assess the adaptability and efficiency of the proposed system under diverse environmental conditions, ultimately identifying the most sustainable and economically viable areas for green hydrogen production in Algeria.

D. Comparative Benchmarking with Leading Countries

A comparative analysis is conducted with leading countries in the green hydrogen sector, known for their significant solar energy potential. Countries such as Mauritania, Germany, and Australia serve as benchmarks in our study. These nations have made substantial advancements in the field of green hydrogen and solar energy, providing valuable insights and best practices that can be adapted and implemented in the Algerian context.

E. Data Acquisition and Analysis

Regarding solar energy resources, our study leveraged NASA's predictions and data to obtain critical insights into global solar energy potential. Utilizing NASA's advanced satellite technology, which monitors solar radiation, we accessed comprehensive data on solar energy availability across various regions. This information was pivotal in identifying optimal locations for solar energy installations and evaluating the feasibility of large-scale solar power projects [82]. Our study, informed by NASA's data, aims to propose effective solar energy solutions tailored to various climatic conditions, contributing to global efforts in sustainable energy development.

The results obtained from these analyses are meticulously processed and discussed. We delve into the performance metrics, economic feasibility, and environmental impact of the proposed systems. The discussion includes an evaluation of the scalability of the systems,

potential challenges in implementation, and the overall benefits of integrating solar energy with hydrogen production. In doing so, we seek to offer a thorough understanding of the viability and sustainability of these renewable energy solutions, both in Algeria and globally.

F. Sensitivity Analysis Using HOMER Pro

A comprehensive sensitivity analysis was performed using HOMER Pro software to evaluate the robustness of the proposed green hydrogen production system. The study examined several key parameters:

❖ Electrolyzer Efficiency:

Efficiency values between 60% and 80% were analyzed to reflect the performance range of commercial electrolyzers. Higher efficiencies resulted in marked improvements in hydrogen production rates, while lower values highlighted the need for further optimization of electrolyzer technology.

❖ Solar Electricity Costs:

Scenarios were modeled with solar electricity costs ranging from \$0.03/kWh to \$0.06/kWh. The analysis demonstrated that lower energy costs significantly enhance the economic feasibility of hydrogen production, thereby positioning Algeria as a competitive contender in the global market.

❖ Water Availability:

The study also considered scenarios with limited freshwater resources to assess the potential for integrating seawater and wastewater treatment. Results indicated that utilizing these alternative water sources not only sustains hydrogen production but also promotes environmental sustainability.

Overall, the HOMER Pro simulation results confirm that the proposed system performs robustly across a wide range of operating conditions, underscoring its adaptability and reliability.

4.4.3 Results And Discussions:

After inputting all relevant data into HOMER Pro software and generating the necessary results for each studied region, we meticulously summarized and compiled these findings. This comprehensive aggregation ensures that the comparative analysis is both clear and highly effective. Organizing the data in this way enables a deeper understanding of the differences and similarities across various areas, thereby improving the overall effectiveness

of our comparison. This approach not only highlights key insights but also supports more informed decision-making regarding energy solutions and their applicability in diverse geographical contexts.

A. Photovoltaic Electricity Generation:

The analysis of the results, as illustrated in the accompanying **Figure 4-3**, indicates that desert regions, notably Tamanrasset (33.5 GWh/year) and Adrar (32.9 GWh/year), exhibit the highest photovoltaic electricity productivity. This exceptional performance is primarily due to their extensive year-round solar irradiation. Nevertheless, the potential of other regions should not be underestimated. For example, Skikda, despite having less favorable solar conditions compared to desert regions, still demonstrates significant photovoltaic electricity productivity, achieving 26.6 GWh/year. When compared to international benchmarks such as Germany (17.8 GWh/year), Australia (18.8 GWh/year), and Mauritania (28.8 GWh/year), Skikda's performance is particularly impressive. Furthermore, Tlemcen in northeastern Algeria has produced 29 GWh/year. These findings underscore the broader viability and potential of photovoltaic systems across diverse geographic locations, highlighting the importance of harnessing solar energy beyond traditionally favorable regions.

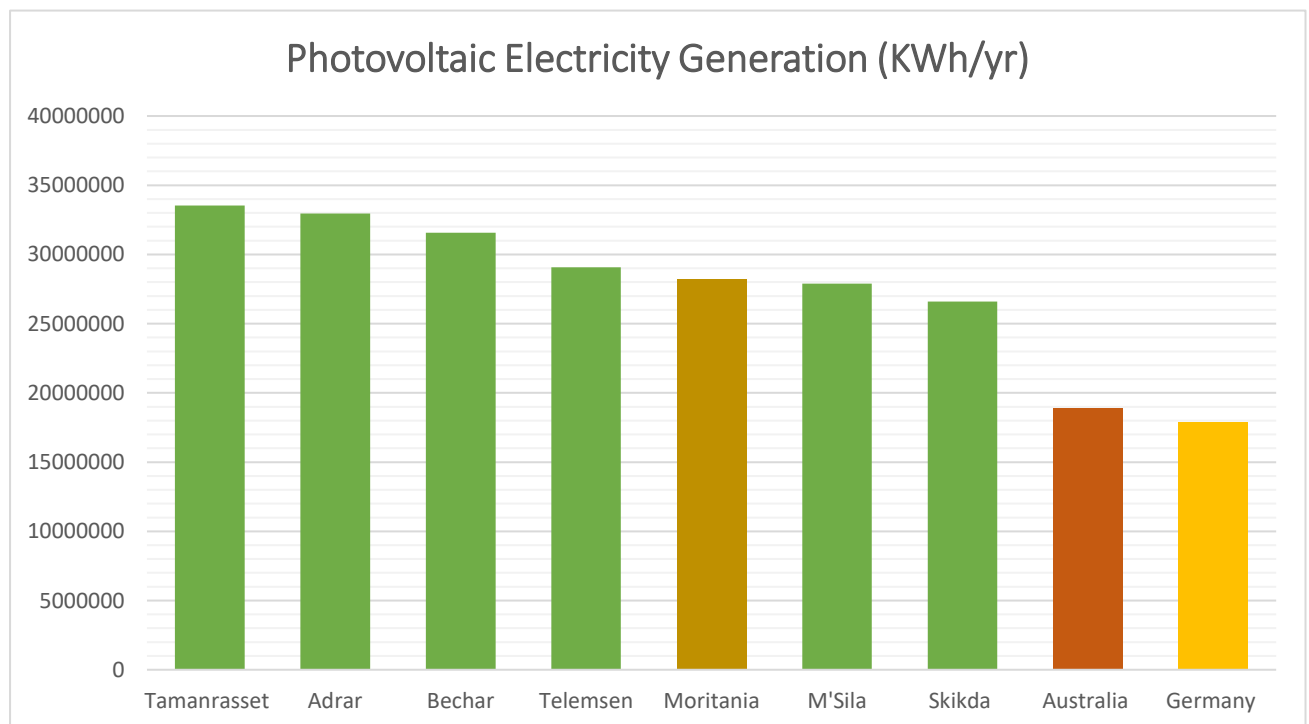

Figure 4-3 Comparative Photovoltaic Electricity Generation in Various Locations Worldwide

B. Green Hydrogen Production:

For the production of green hydrogen, which relies on photovoltaic energy, is most prolific in desert regions. Tamanrasset and Adrar lead with annual outputs of 679 tons and 668 tons,

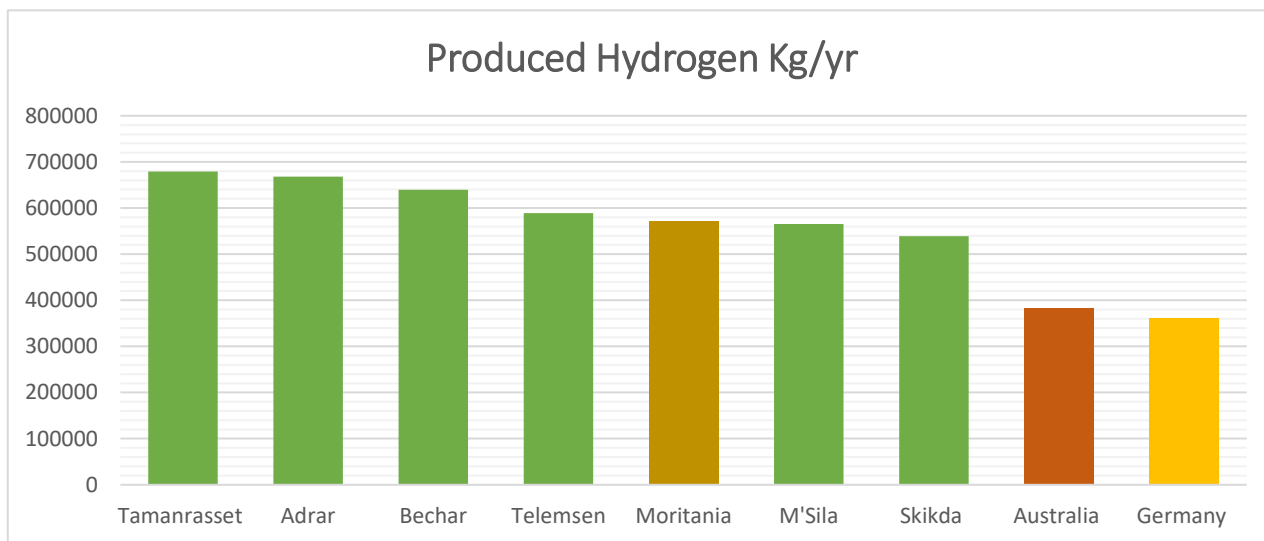

Figure 4-4 Comparative Hydrogen Production in Various Locations Worldwide

Notably, as shown in **Figure 4-5**, significant production is also observed in northern regions such as Telemcen and Skikda, producing 589 tons and 539 tons per year, respectively. When compared internationally, Mauritania produces 571 tons, Germany 361 tons, and Australia 382 tons annually. These figures highlight the substantial potential for green hydrogen production in both desert and non-desert regions, underscoring the feasibility and effectiveness of leveraging photovoltaic energy for sustainable hydrogen generation across various geographic locations in Algeria.

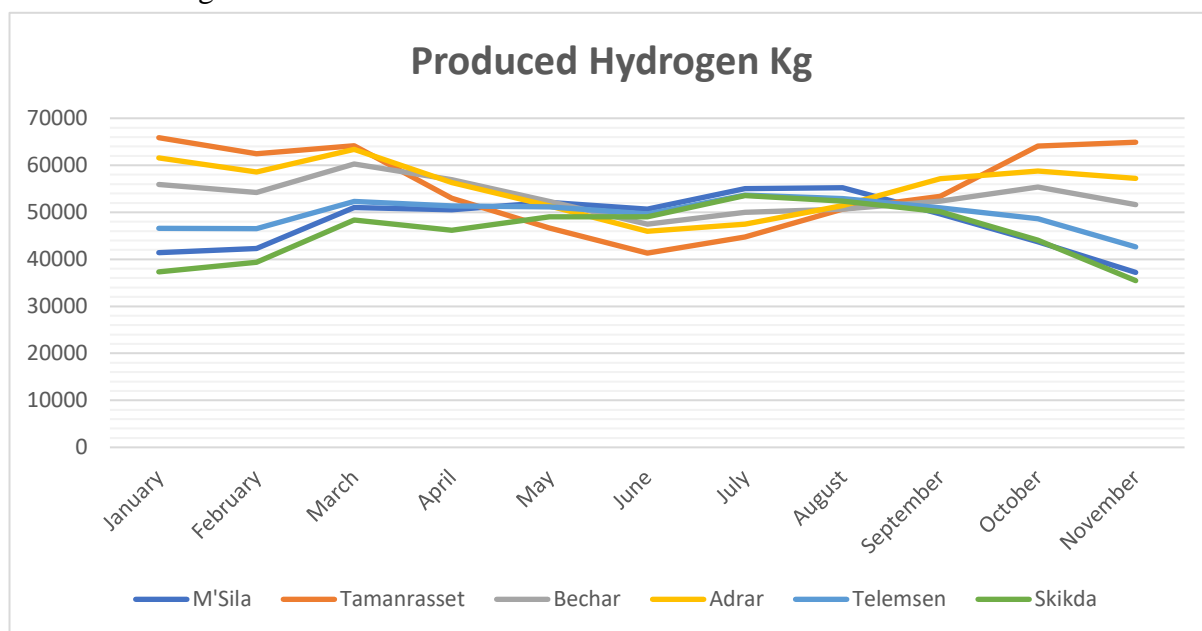

Figure 4-5 Comparative Hydrogen Production in various geographic locations in Algeria

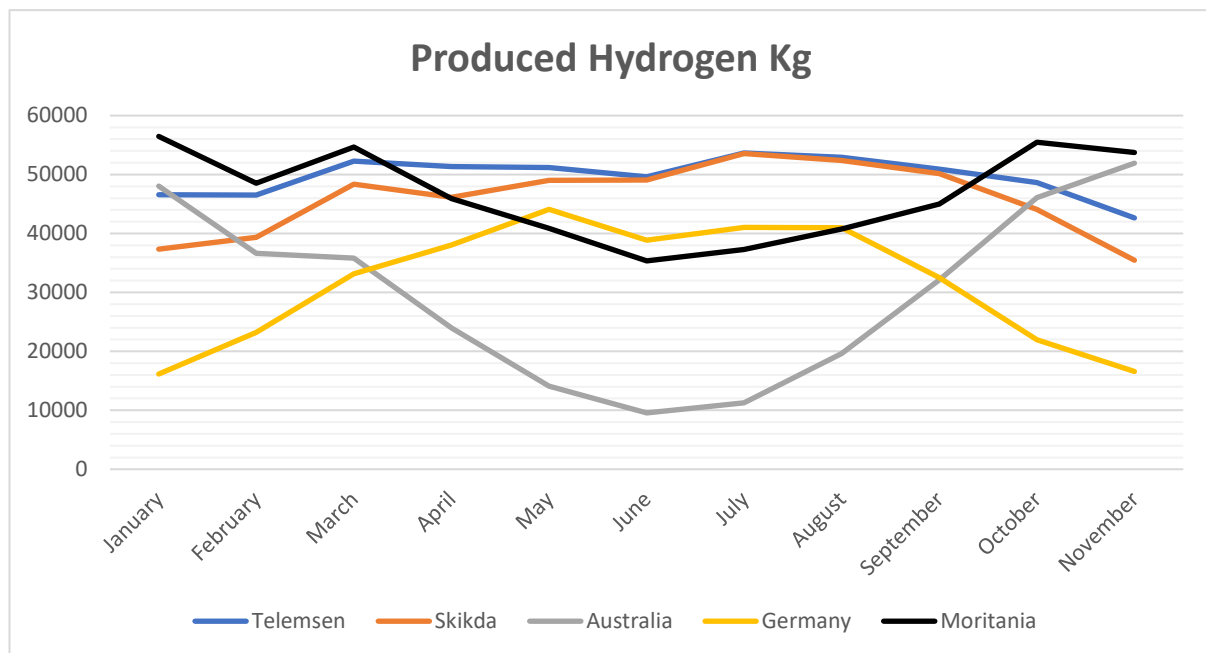

Figure 4-6 Comparative Hydrogen Production in Various Locations Worldwide

C. Water Resources:

Regarding the first element, which is the energy source, our analysis has determined that all regions of Algeria benefit from substantial levels of solar energy, not just the desert areas. The abundant availability of solar energy presents a valuable opportunity for renewable energy projects throughout the country. However, a critical aspect that is often overlooked in such studies is the water source required for green hydrogen production.

While desert regions exhibit high efficiency in solar energy yield due to extensive sunlight, the production of green hydrogen in these areas would primarily rely on groundwater. Groundwater is a crucial resource in desert regions, often being the only available source of water. However, the use of groundwater for green hydrogen production is problematic for several reasons.

- Firstly, groundwater in desert regions is often non-renewable, meaning it replenishes at an extremely slow rate compared to the rate at which it is extracted. This makes reliance on groundwater for industrial processes like green hydrogen production unsustainable in the long term. Over-extraction of groundwater can lead to significant depletion of these aquifers, which can take centuries to naturally replenish. This poses a severe threat to the availability of water for other critical uses, such as drinking water for local populations and irrigation for agriculture.

- Secondly, groundwater depletion can have serious ecological and environmental impacts. Lowering the water table can lead to land subsidence, which can damage infrastructure and reduce the land's ability to support vegetation. This can exacerbate desertification, leading to the loss of arable land and biodiversity. Additionally, groundwater extraction often brings up saline or contaminated water, which can further degrade the quality of the remaining water resources.
- Additionally, the energy-intensive processes involved in desalinating saline groundwater or treating contaminated groundwater increase the overall energy demand and cost of green hydrogen production. This, in turn, reduces the environmental advantages of producing green hydrogen in these regions, as the energy needed for water treatment could offset the benefits derived from utilizing renewable solar energy.

To effectively mitigate these risks, it is crucial to identify and utilize regions with alternative and more sustainable water sources for green hydrogen production. Northern regions of Algeria, for instance, offer significant advantages due to their more consistent and renewable water sources. These include seawater, wastewater from major cities, and higher rainfall. Such regions can support the water-intensive hydrogen production process without the adverse effects associated with groundwater depletion.

Moreover, the hydrogen production process in these areas can be integrated with secondary operations such as wastewater treatment and salt extraction from seawater. This not only optimizes resource use but also adds value through the creation of by-products and the improvement of water management practices.

Focusing on regions with renewable water resources ensures that green hydrogen production remains truly sustainable. This approach aligns with broader goals of environmental stewardship and resource conservation, fostering a balanced integration of renewable energy use while preserving vital natural resources. By adopting this strategy, we can address multiple challenges within the green hydrogen production sector, ensuring its long-term viability and positive environmental impact.

The matter does not stop here, by selecting these areas, we can address several challenges in the green hydrogen sector, including issues related to storage and transportation.

- **Utilizing seawater for green hydrogen and sea salt extraction**

Utilizing seawater for green hydrogen production, combined with sea salt extraction, presents a significant opportunity for sustainable development in Algeria. Establishing hydrogen production facilities along the northern coast enables the country to leverage its abundant marine resources for advancing clean energy solutions. Seawater electrolysis not only generates green hydrogen but also yields valuable sea salt as a by-product, enhancing overall resource efficiency. Research, such as that conducted by He et al. [57], has demonstrated the economic and environmental viability of this approach, emphasizing its potential to lower costs, reduce CO₂ emissions, and produce commercially valuable by-products. This dual-purpose strategy fosters economic diversification while reinforcing Algeria’s commitment to sustainable energy and responsible resource utilization. By integrating green hydrogen production with salt extraction, Algeria can strengthen its local economy, optimize resource management, and minimize environmental impact.

- **Utilizing wastewater for green hydrogen production**

Furthermore, the use of wastewater exceeding 1.5 billion cubic meters annually presents a significant opportunity for advancing sustainable green hydrogen production in Algeria (**Figure 4-7** and **Figure 4-8**). By situating production facilities near major cities in the northern regions, the country can effectively utilize treated wastewater as a crucial resource for electrolysis. This strategy not only reduces reliance on non-renewable groundwater but also mitigates environmental impact by promoting the responsible reuse of wastewater, reinforcing Algeria’s commitment to sustainable resource management.

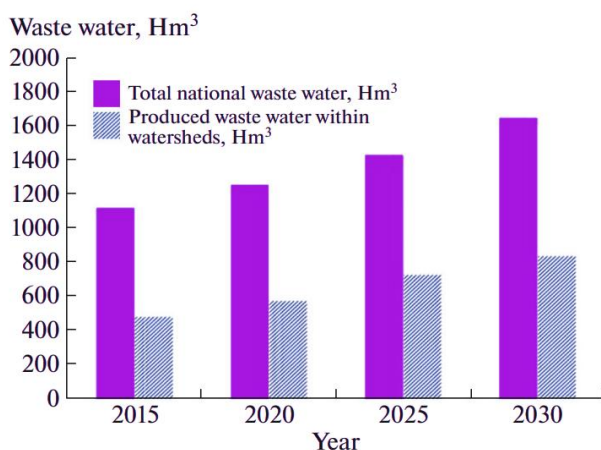

Figure 4-7 A comparison of the characteristic volumes of WWTPs managed by the NSO in 2009

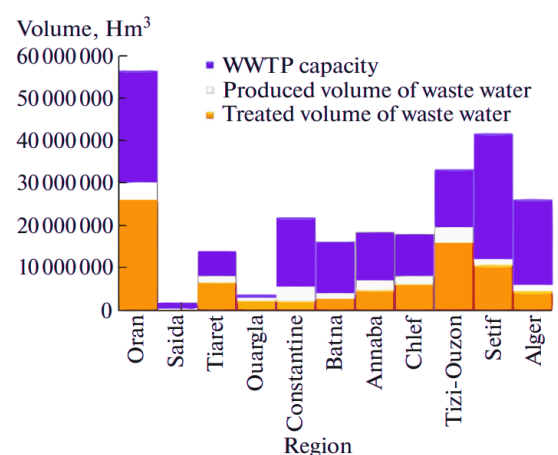

Figure 4-8 The progression of wastewater production within watersheds that are equipped with dams

Research, including the work of Ahmed M. Elgarahy et al. [83], has highlighted the viability of wastewater as a sustainable resource for hydrogen production through electrochemical techniques. Their findings underscore the economic and environmental benefits of electrolysis as an effective method for converting treated wastewater into green hydrogen. By adopting this approach, Algeria can optimize resource utilization while simultaneously addressing challenges in urban water management.

Integrating wastewater treatment with hydrogen production enhances overall resource efficiency and contributes to a more comprehensive water management strategy. These initiatives reflect Algeria's commitment to advancing eco-friendly energy solutions while tackling urban water resource challenges, aligning with broader environmental sustainability objectives. Moreover, treated wastewater represents a promising source for green hydrogen production, particularly in areas near dams where substantial water reserves are available. This water can be utilized in electrolysis processes to produce hydrogen, reducing dependence on freshwater resources and promoting sustainability. By incorporating treated wastewater into green hydrogen production, Algeria can strengthen its renewable energy strategy and optimize water resource management, making use of existing dam infrastructure and wastewater treatment facilities.

4.4.4 Strategic Advancements in Hydrogen Utilization and Exportation

Hydrogen is a highly versatile resource with applications across multiple sectors, including energy, industry, and transportation. Global demand for hydrogen is rapidly increasing, while supply struggles to keep pace. Currently, Algeria does not utilize hydrogen domestically, making the most strategic option to export its production to international and European markets. This is particularly advantageous given the rising global demand for green hydrogen, with prices reaching up to \$5.6 (756 DA) per kilogram in the European Union. By capitalizing on this market, Algeria stands to gain substantial economic benefits.

A detailed economic analysis of hydrogen production costs (LCOH) further reinforces Algeria's competitiveness in the green hydrogen sector. As illustrated in **Figure 4-9**, southern regions such as Tamanrasset and Adrar achieve the lowest production costs at 1.68 \$/kg (227 DA/Kg) and 1.70 \$/kg (230 DA/Kg), respectively, due to their abundant solar irradiation. Meanwhile, northern regions, including Tlemcen and Skikda, also demonstrate competitive costs of 1.92 \$/kg (259 DA/Kg) and 2.11 \$/kg (285 DA/Kg), respectively. These figures are significantly lower than those recorded in leading global producers such as Australia 2.94 \$/kg

(397 DA/Kg) and Germany 3.11 \$/kg (420 DA/Kg). This cost advantage positions Algeria's northern regions as promising hubs for hydrogen production and export, benefiting from their access to sustainable water resources and well-established export infrastructure.

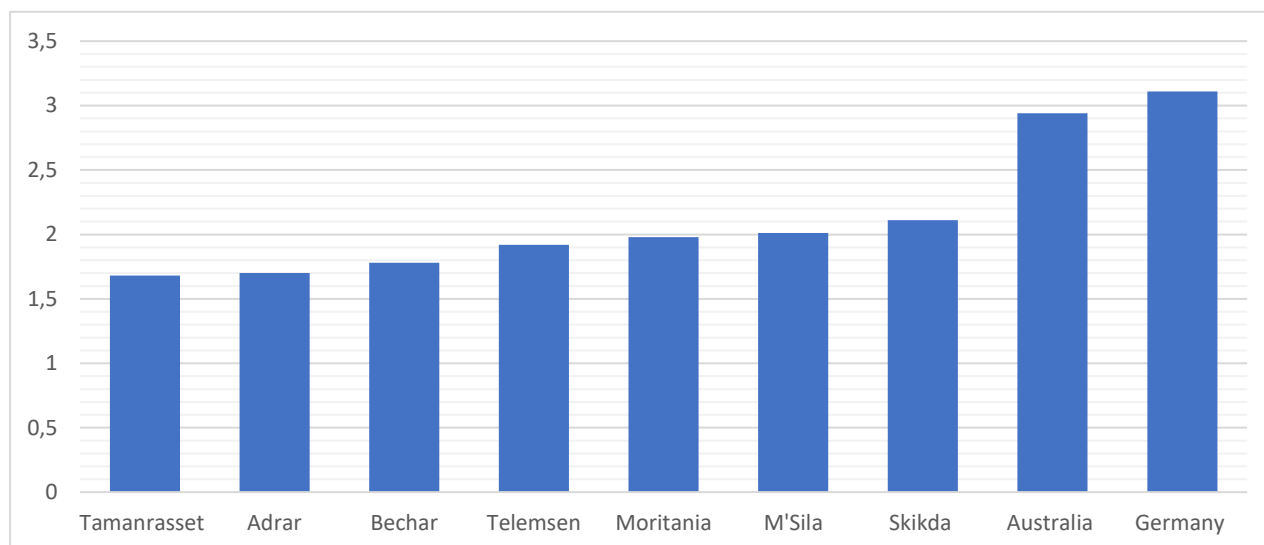

Figure 4-9 Comparative Levelized Cost of Hydrogen in Various Locations Worldwide

A. Tackling the challenges of storage and transportation:

One of the primary challenges in the hydrogen industry is the storage and transportation of green hydrogen, given its low density and the significant costs associated with its handling. These challenges are particularly critical in regions with extreme climatic conditions, such as Algeria's southern desert. Establishing hydrogen production facilities in northern Algeria offers a strategic solution by reducing transportation costs and logistical complexities. Proximity to major ports facilitates efficient export operations while minimizing the risks associated with storing and transporting hydrogen in high-temperature desert environments.

Algeria's recent initiatives further reinforce its ambition to emerge as a key player in the global green hydrogen market. A prominent example is the Corridor Sud H2 project, which aims to transport approximately 4 million tons of green hydrogen annually to Italy and other European destinations. Developed in collaboration with Italy, Germany, Austria, and Tunisia, the project entails the construction of over 3,300 kilometers of hydrogen transport infrastructure. By leveraging existing natural gas pipelines and Algeria's strategic geographical position near Europe, this initiative underscores the country's competitive edge in hydrogen exports.

The findings of this study align closely with the objectives of the Corridor Sud H2 project, particularly by identifying northern Algeria as a key region for hydrogen production and export

integration. Collectively, these efforts position Algeria as a critical link between Africa and Europe in the global energy transition.

B. Leveraging existing infrastructure for efficient export:

Furthermore, situating green hydrogen production stations near Algeria's natural gas export pipelines offers a practical solution to the storage and transportation challenges. Pipelines such as the Galsi pipeline to Italy in Skikda and the gas pipeline to Almeria in Oran are already equipped and capable of transporting green hydrogen. By injecting hydrogen into these existing pipelines and blending it with natural gas, Algeria can efficiently export hydrogen to international markets. This approach addresses storage and transportation challenges while capitalizing on Algeria's existing infrastructure, thereby improving the efficiency and cost-effectiveness of hydrogen export.

By strategically utilizing its geographical location and established infrastructure, Algeria can tackle key obstacles in the hydrogen sector, positioning itself as a prominent player in the rapidly growing global green hydrogen market. **Figure 4-8** illustrates the strategic plan to repurpose Algeria's natural gas pipeline infrastructure for the efficient export of green hydrogen.



Figure 4-10 Leveraging Existing Infrastructure for Green Hydrogen Export in Algeria [84]

C. Utilizing Hydrogen for Power Generation in Micro-grids:

An intriguing avenue for future research focuses on utilizing hydrogen to generate electricity during periods without sunlight, employing fuel cells as an alternative to conventional batteries in microgrids. This innovative approach seeks to establish a self-sufficient and environmentally sustainable energy system with zero emissions. Fuel cells, which produce electricity from hydrogen through an electrochemical process, offer distinct

advantages over batteries, such as higher energy efficiency, longer lifespan, and faster refueling. Integrating hydrogen fuel cells into microgrid configurations ensures a reliable and uninterrupted power supply, even in the absence of solar energy. This integration not only enhances the resilience and sustainability of microgrids but also decreases dependency on fossil fuels, contributing to lower greenhouse gas emissions. Adopting this technology could accelerate the transition to clean energy systems, bolstering global efforts to mitigate climate change and promote sustainable development.

D. Expanding Solar Power Plants for Green Hydrogen Production:

Building on existing advancements, Algeria's solar power plants offer a promising platform for further innovation. These facilities can be optimized to harness surplus energy produced during peak sunlight hours for green hydrogen production. Through the application of electrolysis technology, excess solar power can be transformed into hydrogen gas, which can then be stored and utilized as a clean fuel or industrial feedstock. This approach not only improves the efficiency of solar power plants but also diversifies Algeria's energy mix. Integrating green hydrogen production with solar energy systems aligns with the nation's objectives of reducing carbon emissions, advancing renewable energy adoption, and establishing itself as a key player in the global shift toward sustainable energy. Furthermore, this strategy addresses one of the main challenges of renewable energy storage by offering a practical and scalable solution, ensuring a steady and reliable supply of clean energy.

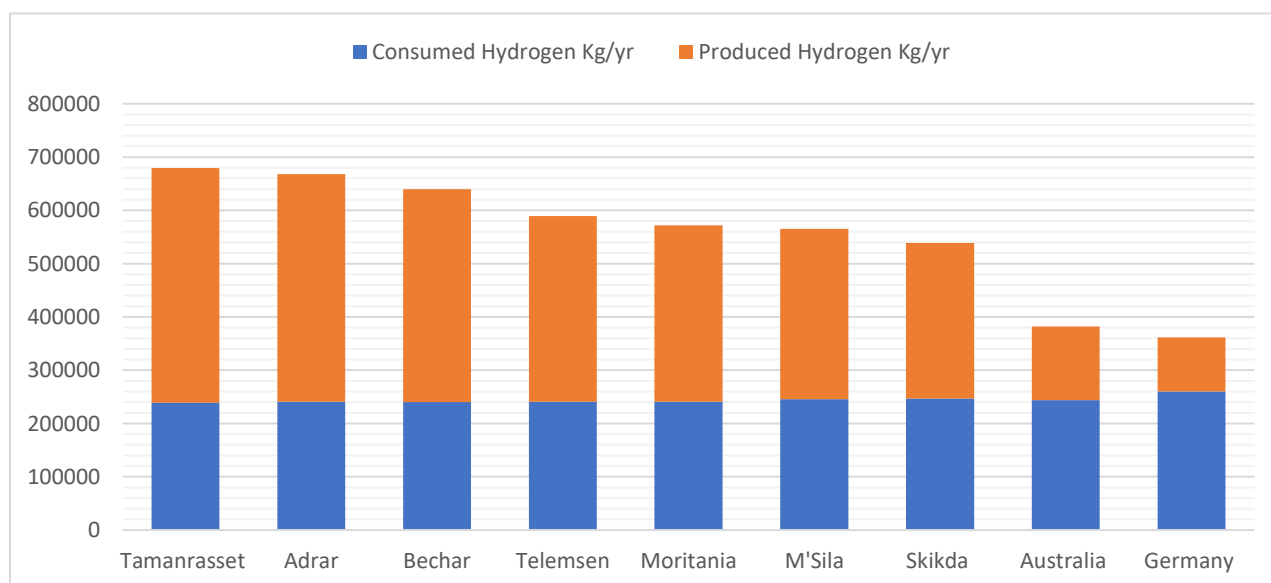

Figure 4-11 Hydrogen Production and Consumption by Region (Kg/year)

E. Expanding Solar Power Plants for Green Hydrogen Production:

Several nations, including Germany, Australia, and Saudi Arabia, have made significant strides in green hydrogen production. However, Algeria possesses a unique blend of geographical, resource-based, and economic advantages that position it as a strong contender in this emerging sector. The country benefits from consistent solar irradiation across both its northern and southern regions, enabling year-round high photovoltaic efficiency. This contrasts with countries like Germany, where solar energy potential is more constrained. Additionally, Algeria's proximity to European markets provides a strategic logistical edge, allowing for cost-effective hydrogen export. The presence of an extensive natural gas pipeline network further enhances its competitiveness, as these pipelines can be repurposed for hydrogen transport, significantly reducing the financial and technical burden of building new infrastructure. Furthermore, Algeria has access to alternative water sources, including seawater and treated wastewater, reducing dependence on freshwater a key advantage over countries like Australia, which rely heavily on desalination.

Economic Feasibility and Long-Term Viability

Beyond its technical and logistical strengths, Algeria's green hydrogen strategy is reinforced by its economic viability. Current estimates indicate that green hydrogen production costs in Algeria, using photovoltaic energy, range between 4 \$ (540 DA) and 6 \$ (810 DA) per kilogram, driven by the country's exceptionally low solar electricity cost of approximately 0.04 \$/kWh (5.4 DA/kwh). These competitive figures position Algeria among the most cost-efficient producers globally.

Moreover, repurposing existing infrastructure, such as natural gas pipelines, significantly reduces capital expenditure related to hydrogen transport to European markets. However, ensuring long-term competitiveness requires addressing the upfront costs associated with electrolyzer installation and water treatment facilities. Initiatives such as the Corridor Sud H2 project play a crucial role in attracting foreign investment and stimulating market demand, further solidifying Algeria's standing in the global green hydrogen landscape.

4.5 Case Study: Feasibility of Expanding Solar Power for Green Hydrogen in M'Sila, Algeria

Algeria is one of the leading countries endowed with immense natural potential in solar energy, making it a strong candidate for developing innovative projects in green hydrogen production. In this context, the feasibility study conducted in the M'sila region highlights the opportunity to harness surplus solar energy to establish an integrated green hydrogen production project, aligning with national efforts to achieve energy sustainability.

The study focuses on the design of a comprehensive system consisting of 2 MW photovoltaic solar panels, an energy storage unit utilizing batteries, and a 2 MW electrolyzer. The project demonstrates the system's capacity to supply electricity to approximately 150 households while producing over 64,000 kilograms of green hydrogen annually from surplus energy. Additionally, it offers an in-depth economic analysis of financial viability and highlights environmental benefits, such as significant reductions in carbon emissions.

This section will delve into the experimental findings and outcomes of this study, linking them to broader efforts to expand the use of solar power plants for green hydrogen production. These advancements contribute to positioning Algeria as a key player in the renewable energy sector and a strong supporter of the global transition toward sustainable energy solutions.

4.5.1 Overview Of The System

The system consists of a 2 MW solar photovoltaic array, a 192 kWh battery storage unit, and a 2 MW electrolyzer. It is designed to supply electricity to a city of 150 households, with a daily consumption of 210 MWh. Surplus electricity generated during daylight hours is used to produce green hydrogen, which is stored for potential export or industrial use (**Figure 4-12**). This off-grid setup is optimized for M'Sila's high solar irradiance, ensuring efficient operation and maximum energy utilization.

The **Table 4-2** represent the Specifications of PV panels.

<i>Table 4-2 Specifications of PV panels</i>	
Capital cost per kW	360 \$ (48600 DA)
Replacement cost per kW	360 \$ (48600 DA)
O-M cost per kW	10 \$ (1350 DA)
Lifetime(years)	25
Efficiency	20 %

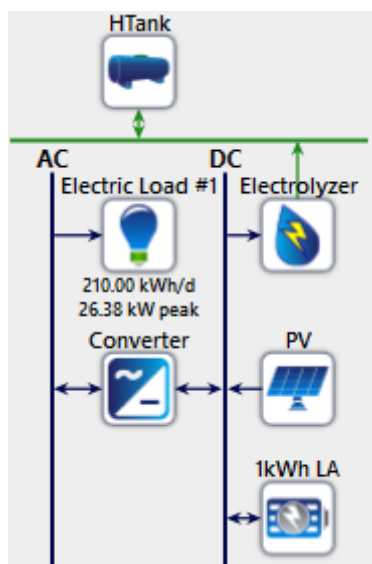

Figure 4-12 Illustration of the designed system

The **Table 4-3** represent the Specifications of battery storage.

<i>Table 4-3 Specifications of battery storage</i>	
Capital cost per kW	140 \$ (18900 DA)
Replacement cost per kW	140 \$ (18900 DA)
O-M cost per kW	10 \$ (1350 DA)
Lifetime (years)	7
Efficiency	80 %

The **Table 4-4** represent the Specifications of power electronic converters.

<i>Table 4-4 Specifications of power electronic converters</i>	
Capital cost per kW	155 \$ (20900 DA)
Replacement cost per kW	155 \$ (20900 DA)
O-M cost per kW	10 \$ (1350 DA)
Lifetime (years)	25
Efficiency	95 %

The **Table 4-5** represent the Specifications of Electrolyzer.

<i>Table 4-5 Specifications of Electrolyzer</i>	
Capital cost per kW	1500 \$ (202500 DA)
Replacement cost per kW	700 \$ (94500 DA)
O-M cost per kW	10 \$ (1350 DA)
Lifetime (years)	15
Efficiency	85 %

4.5.2 System Operation

A. Electricity Generation and Consumption

The solar panels generate electricity during daylight hours to meet the energy needs of the community. Any surplus energy, after addressing the 210 KWh annual consumption of 150 households, is directed toward hydrogen production.

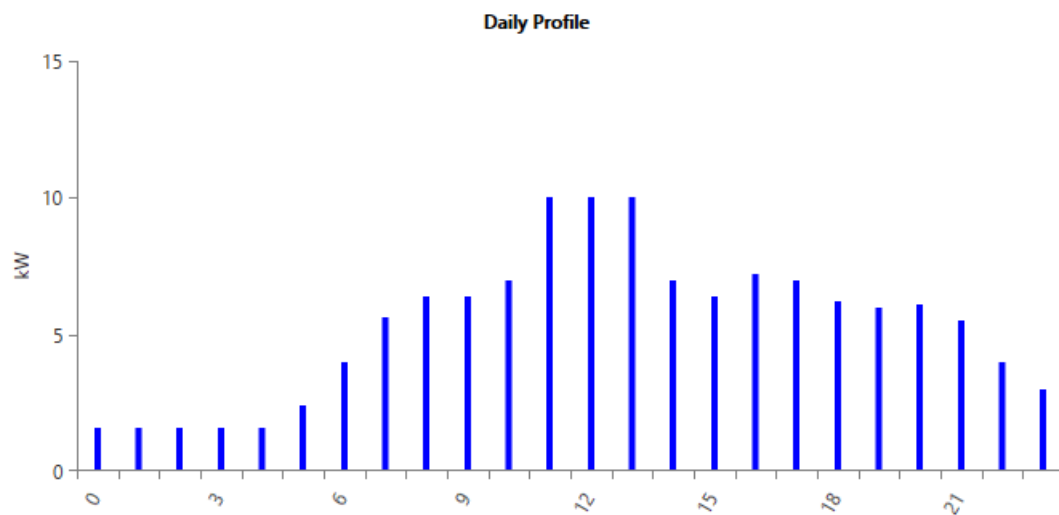

Figure 4-13 Electricity demand profile

B. Hydrogen Production

The surplus energy powers the electrolyzer, which produces green hydrogen by splitting water into hydrogen and oxygen without any carbon emissions. This hydrogen is stored and made available for export or other industrial applications, presenting a new revenue stream for Algeria.

C. Renewable Energy Potential Of The Site

In the sun-abundant region of M'Sila, Algeria, the proposed system was assessed using solar irradiance data processed through HOMER software. The energy output of the photovoltaic system is influenced by solar radiation and ambient temperature, both of which were analyzed to determine the region's power generation potential. As depicted in **Figure 4-12**, solar radiation varies, with a daily average minimum of 4.5 kWh/m² and peaks observed during the months of May, June, July, and August. The average daily temperature further underscores the region's suitability for solar energy production. Additionally, the electric load profile, illustrated in **Figure 4-11**, shows a peak demand of 10 kWh occurring between 11:00 AM and 1:00 PM, with an average daily consumption of 210 kWh.

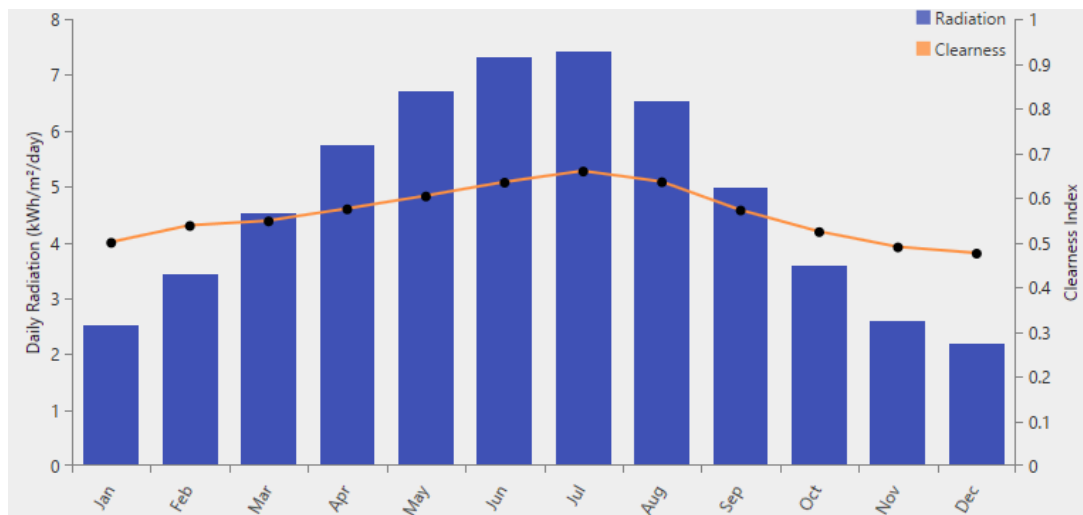

Figure 4-14 Variation in solar radiation and clearness index

4.5.3 Simulation Results and Economic Analysis

A. Hydrogen Production

The system produces 64,342 kilograms of green hydrogen annually. This production level is consistent with the surplus energy available from the solar panels after meeting the city’s energy demand. Over the 25-year lifespan, the system will generate approximately 1.61 million kilograms of hydrogen, showcasing its potential for long-term energy export. (Figure 4-14).

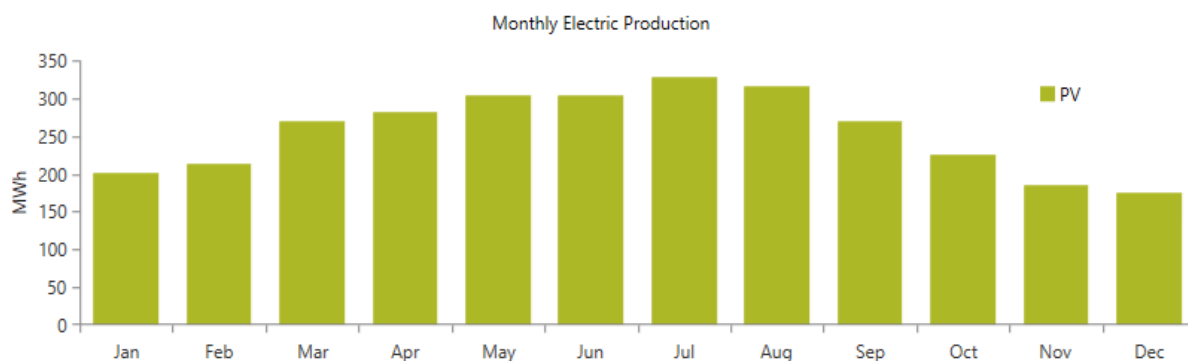

Figure 4-15 Monthly electricity generation

B. Environmental Impact

One of the most significant findings is the system's zero greenhouse gas emissions. By utilizing solar power and water as feedstock, the system offers an environmentally friendly solution that aligns with global decarbonization goals. This advantage positions Algeria as a contributor to combating climate change while fostering sustainable development.

Quantity	Value	Units
Carbon Dioxide	0	kg/yr
Carbon Monoxide	0	kg/yr
Unburned Hydrocarbons	0	kg/yr
Particulate Matter	0	kg/yr
Sulfur Dioxide	0	kg/yr
Nitrogen Oxides	0	kg/yr

Production	kg/yr	%
Electrolyzer	64,342	100
Reformer	0	0
Total	64,342	100

Figure 4-16 System Emissions

C. Economic Potential of Green Hydrogen

Global green hydrogen prices range between \$5 (675 DA) and \$12 (1 620 DA) per kilogram. For this project, we conservatively assume a market price of \$6.50 (877 DA) per kilogram, balancing profitability with realistic market conditions. **(Figure 4-15)**

- **Annual Revenue:** At this price, the system generates 418 223 \$ (56 460 105 DA) annually, showcasing its potential as a revenue-generating asset.
- **Total Revenue Over 25 Years:** Over its lifespan, the project earns 10 455 575 \$ (1 411 502 625 DA), providing a return well above the initial investment.

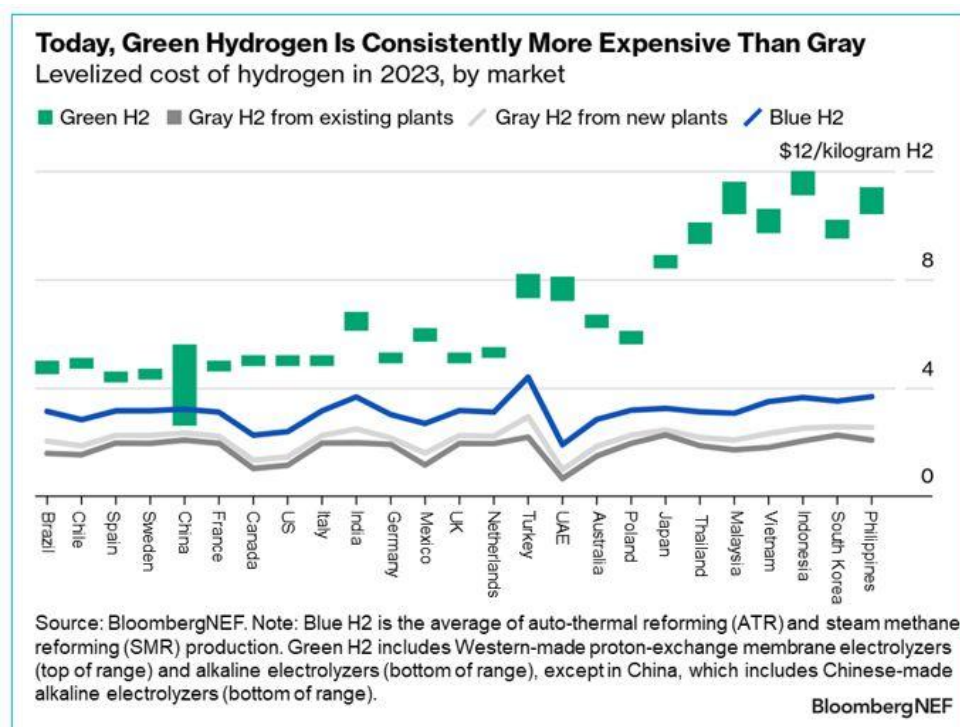

Figure 4-17 Green Hydrogen Prices in 2023

4.5.4 Analysis Of Profitability

A. Price Sensitivity

The profitability of the project is sensitive to hydrogen market prices. If prices rise above 6.50 \$ (877 DA) per kilogram toward the higher end of the global range profit margins will significantly improve, reducing the payback period and increasing ROI. For instance, at 7.5 \$/kg (1012 DA), the project would recover costs within 17 years and yield a profit of over 3 million dollars (405 000 000 DA) .

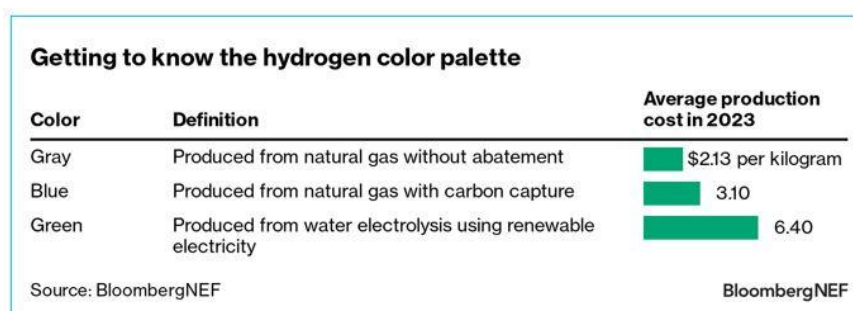

Figure 4-18 Green, Gray and Blue Hydrogen Prices in 2023

B. Risk Mitigation

By relying on solar energy, the project avoids exposure to volatile fossil fuel prices. Additionally, the increasing global demand for green hydrogen, driven by decarbonization policies in regions like Europe and Asia, reduces market risk.

4.5.5 Commentary On Results And Implications

The findings indicate that the project is both economically and environmentally viable under the assumed market conditions. The long break-even period may deter some investors, but the broader strategic and environmental benefits make it a worthwhile endeavor for Algeria.

A. Economic Impacts

The project diversifies Algeria’s energy exports, reducing reliance on hydrocarbons while tapping into the lucrative and growing global green hydrogen market. The modest net profit also demonstrates that renewable energy projects can be financially sustainable in the long run.

B. Environmental Benefits

The project's zero-emission design is a significant advantage in a world increasingly prioritizing decarbonization. This positions Algeria as a responsible energy exporter, capable of meeting the stringent environmental standards of markets like the European Union.

C. Strategic Positioning

Algeria's proximity to key markets, such as Europe and Asia, provides a logistical advantage for hydrogen exports. Moreover, early adoption of green hydrogen technology could establish Algeria as a leader in renewable energy, attracting foreign investment and technological partnerships.

D. Long-Term Potential

Beyond its current scale, this pilot project serves as a proof-of-concept for larger-scale initiatives. Expanding the system to integrate the nearby 20 MW solar power plant in M'Sila could amplify hydrogen production and revenue, transforming the region into a hub for green hydrogen.

4.6 Cost and Efficiency Challenges

The production of green hydrogen faces significant cost and efficiency barriers, which impede its large-scale implementation. High capital costs remain a central issue, as advanced electrolyzers and photovoltaic (PV) systems demand substantial investments. These costs are compounded by operational inefficiencies in energy conversion processes, which lead to energy losses during both electrolysis and the utilization of hydrogen in fuel cells. Additionally, the absence of a mature global market for green hydrogen restricts economies of scale, further inflating production costs. These challenges create a feedback loop where high costs limit adoption, and limited adoption prevents the cost reductions associated with large-scale deployment.

To address these challenges, a multi-faceted approach is necessary. Technological innovation must take center stage, with focused research on improving the efficiency and longevity of electrolyzers and PV systems. Governments and international organizations can play a pivotal role by providing financial incentives such as subsidies and grants to reduce initial investment barriers. Additionally, promoting localized manufacturing of renewable energy technologies can mitigate costs associated with imports and logistics. By integrating these strategies, the financial and operational viability of green hydrogen production can be significantly enhanced.

4.7 Sustainable Water Resource Utilization

Water availability is a critical factor in green hydrogen production, particularly in regions like Algeria where water scarcity is a pressing concern. The reliance on freshwater for electrolysis raises ethical and environmental questions, given competing demands for this resource. Utilizing seawater and treated wastewater for hydrogen production offers promising alternatives, but these solutions introduce their own technical and economic complexities. Desalination and wastewater treatment processes require advanced technologies and energy inputs, potentially offsetting the environmental benefits of green hydrogen.

A shift toward sustainable water resource utilization involves several innovative solutions. Seawater electrolysis, which bypasses the need for extensive desalination, is a key area of research that could revolutionize the sector. Similarly, expanding infrastructure for wastewater collection and treatment can make this underutilized resource a viable option for hydrogen production. Energy-efficient treatment technologies must be prioritized to minimize the environmental and economic costs of these processes. By adopting these strategies, Algeria can achieve a balance between green hydrogen production and responsible water management, ensuring the sustainability of its energy transition.

4.8 Integrating Renewable Energy into the National Grid

The integration of renewable energy sources into Algeria's national grid is essential for scaling up green hydrogen production. However, the inherent variability of solar and wind energy poses significant challenges to grid stability. Fluctuations in energy output can lead to disruptions, while limited energy storage capacity further constrains the efficient use of renewable resources. Existing grid infrastructure, designed for conventional energy systems, often lacks the flexibility required to accommodate the intermittent nature of renewables.

Overcoming these challenges requires strategic investments in energy storage systems and grid modernization. Battery storage and hydrogen storage technologies can play a vital role in balancing supply and demand, ensuring a consistent energy flow. Smart grid technologies, which employ advanced management systems, can enhance the efficiency and adaptability of the national grid to renewable energy inputs. Furthermore, hybrid energy systems that combine multiple renewable sources, such as solar and wind, can mitigate the effects of variability, providing a more stable energy supply. By implementing these solutions, Algeria can create a

robust and resilient energy infrastructure capable of supporting the growth of green hydrogen production.

4.9 Summary of Key Findings

This research highlights the immense potential of green hydrogen in driving the transition to clean and sustainable energy in Algeria. By leveraging abundant natural resources such as solar energy and saline water, Algeria can position itself as a global leader in this field. The key findings include:

- Algeria possesses one of the highest solar irradiation levels globally, making it an ideal location for producing green hydrogen using photovoltaic systems.
- The development of green hydrogen requires sustainable water resource management, including the use of saline water and innovative wastewater treatment processes.
- The integration of hydrogen with renewable energy can contribute to the stability of the national grid and reduce reliance on fossil fuels.
- Existing infrastructure, such as pipelines for export, provides a strategic advantage for integrating green hydrogen into European markets.

4.10 Recommendations for Developing Green Hydrogen in Algeria

To fully harness the available potential, the following priorities are recommended:

1. Enhance Local Research and Development:

- Establish specialized research centers to improve electrolysis technologies and boost photovoltaic efficiency.
- Develop innovative water desalination solutions using renewable energy.

2. Diversify Water Sources:

- Invest in advanced wastewater treatment technologies.
- Expand seawater desalination projects powered by solar energy.

3. Modernize Infrastructure:

- Develop hydrogen storage and transportation networks.
- Enhance the efficiency of the national grid to accommodate intermittent renewable energy sources.

4. Promote International and Regional Partnerships:

- Establish agreements with European countries for green hydrogen exports.
- Collaborate with global companies to locally develop advanced technologies.

5. Implement Supportive Legislation and Incentives:

- Create a regulatory framework that supports green hydrogen projects.
- Provide incentives for local and foreign companies to invest in this sector.

4.11 Future Research Directions

The findings of this research open up new horizons for several future studies that could further support the development of green hydrogen in Algeria. Key proposed directions include:

1. Develop Solar-Powered Water Desalination Technologies:

- Enhance the efficiency of membrane-based desalination systems.
- Study the impact of raw water quality on the performance of various systems.

2. Innovate Hydrogen Storage Solutions:

- Develop advanced storage systems based on metal hydrides.
- Explore the use of natural caverns for large-scale hydrogen storage.

3. Integrate Hydrogen into Sustainable Transport:

- Research applications of fuel cells in cars and buses.
- Evaluate the feasibility of developing infrastructure for hydrogen refuelling stations.

4. Integrate Renewable Energy and Hydrogen Systems:

- Study optimal models for integrating hydrogen with solar and wind energy.
- Improve management technologies for hybrid energy grids.

5. Assess Environmental and Economic Impacts:

- Conduct in-depth studies on the environmental impacts of green hydrogen projects.
- Analyze cost-benefit scenarios to determine long-term economic viability.

4.12 Conclusion

This chapter provided a comprehensive analysis of green hydrogen production opportunities in Algeria, highlighting previous research efforts, critical gaps, and the relevance of current work. Through simulation-based assessments using HOMER Pro, strategic advancements in hydrogen production and exportation were explored, culminating in a detailed feasibility study for M'Sila. Challenges related to cost, efficiency, and sustainable water usage were critically evaluated, alongside the importance of integrating renewable energy into the national grid. The findings underline the urgent need for a coordinated national strategy to leverage Algeria's renewable resources effectively, ensuring green hydrogen becomes a cornerstone of the country's energy transition and future export economy.



General Conclusion

General Conclusion

This thesis has meticulously examined the transformative potential of green hydrogen production in Algeria within the context of global energy transitions and sustainable development. The exploration began with an in-depth analysis of the global energy crisis in Chapter 1, highlighting the escalating global energy demand, the profound impact of climate change on energy systems, geopolitical instabilities, and the critical role of green hydrogen as a versatile solution. Defined as hydrogen produced from renewable sources, green hydrogen emerges not only as a means to decarbonize various sectors but also as a key driver for enhancing energy security and supporting global climate goals.

Algeria's strategic position in the renewable energy transition was emphasized in Chapter 2, which reviewed the country's abundant solar and wind energy resources. The chapter underscored Algeria's potential as a significant contributor to the global green hydrogen market, leveraging its geographical advantages and existing infrastructure for exporting hydrogen to Europe and beyond. This strategic positioning not only enhances Algeria's economic growth but also positions the country as a leader in the renewable energy sector, fostering regional stability and global competitiveness.

Chapter 3 delved into advanced systems and technologies for green hydrogen production, focusing on innovations such as photovoltaic-driven electrolysis, advanced electrolyzer modeling, and the integration of storage systems with renewable energy grids. These technological advancements are essential for optimizing efficiency, reducing production costs, and overcoming logistical challenges associated with hydrogen storage and transportation.

Building upon this foundation, Chapter 4 provided a comprehensive analysis of green hydrogen production specifically tailored to Algeria's context. It synthesized previous research findings, identified critical gaps in water resource management and hydrogen infrastructure, and proposed strategic recommendations for enhancing local research and development, diversifying water sources, and modernizing infrastructure. The chapter highlighted the economic potential of green hydrogen, demonstrating its feasibility in Algeria and its capacity to contribute to energy sustainability, economic resilience, and environmental stewardship.

In conclusion, this thesis contributes significantly to advancing the understanding and implementation of green hydrogen technologies in Algeria. By advocating for innovation,

Improving the performance of energy systems from renewable sources based on green hydrogen

General Conclusion

collaboration, and strategic investments, Algeria can capitalize on its renewable energy potential to lead the global transition towards a sustainable and low-carbon future. Moving forward, continued efforts in research and development, coupled with supportive policies and international partnerships, will be crucial in realizing Algeria's vision of becoming a global leader in green hydrogen production.

Future Perspectives and Directions

To further expand research and practical applications in green hydrogen production, the following future directions are proposed:

- **Development of Realistic Electrolyzer and Fuel Cell Models:** Conducting experimental studies to compare real-world performance with simulation results, facilitating the creation of a reliable digital twin for monitoring device performance and diagnosing faults.
- **Enhancing the Use of Wastewater in Green Hydrogen Production:** Emphasizing water recycling to achieve both environmental and economic sustainability while reducing reliance on freshwater sources.
- **Utilizing Seawater for Hydrogen Production:** Exploring electrolysis-based hydrogen generation from seawater while extracting salt as a valuable by-product.
- **Assessing the Feasibility of Producing Green Hydrogen from Surplus Energy:** Integrating electrolysis technologies into Algeria's power plants to make efficient use of excess renewable energy.
- **Developing Advanced Hydrogen Storage and Transportation Strategies:** Improving supply chain efficiency and ensuring safe storage and distribution.
- **Enhancing Electrolyzer and Fuel Cell Efficiency:** Innovating materials and engineering designs to increase productivity and reduce operational costs.
- **Strengthening Collaboration with the Directorate of Energy:** Promoting national projects for green hydrogen production aligned with Algeria's energy strategy and transition toward clean energy sources.

These future directions emphasize the critical role of scientific research in transforming Algeria into a regional hub for green hydrogen, leveraging its natural resources and existing infrastructure to support a sustainable energy transition.

Bibliography

- [1] H. Syed Asad, R. Faran and S. Rehan, "The perspective of energy poverty and 1st energy crisis of green transition," *Energy*, vol. 275, p. 127487, 2023.
- [2] G. Lazar and K. Mikhail, "Energy Transition Manifesto: A Contribution towards the Discourse on the Specifics Amid Energy Crisis," *Energies*, vol. 15, no. 23, p. 9199, 2022.
- [3] H. Youcef, R. Shafiqur and M. Ali, "Overview of the Role of Energy Resources in Algeria's Energy Transition," *Energies*, vol. 15, no. 25, p. 4731, 2022.
- [4] A. B. Stambouli, "Algeria's journey towards a green hydrogen future: Strategies for renewable energy integration and climate commitments," *International Journal of Hydrogen Energy*, vol. 58, pp. 753-763, 2024.
- [5] L. Yang, "Energy structure and carbon emission: Analysis against the background of the current energy crisis in the EU," *Energy*, 1 October 2023.
- [6] S. R. Department, "Global primary energy consumption 2000-2023," Statista, 2024.
- [7] I. E. A. (IEA), "Electricity 2024," International Energy Agency, Paris, 2024.
- [8] M. Cook, "Chapter 2 - Trends in global energy supply and demand," *Developments in Petroleum Science*, vol. 71, pp. 15-42, 2021.
- [9] E. Institute, "Statistical Review of World Energy," Energy Institute, London, 2024.
- [10] A. Olabi and A. Mohammad Ali, "Renewable energy and climate change," *Renewable and Sustainable Energy Reviews*, vol. 158, April 2022.
- [11] M. O. H. Centre, "Average temperature anomaly, Global," Met Office Hadley Centre, 2025.
- [12] K. Khan, K. Adnan and C.-F. Javier, "Energy security analysis in a geopolitically volatile world: A causal study," *Resources Policy*, vol. 83, June 2023.
- [13] N. McCarthy, "Europe is Highly Dependent on Russian Gas," stasista, 2014.
- [14] S. Gaetano, M. Gaetano and N. Agatino, "The green hydrogen revolution," *Renewable Energy*, vol. 216, 2023.
- [15] K. J. F. Hu and A. Xiaomeng, "Comparative study of alkaline water electrolysis, proton exchange membrane water electrolysis and solid oxide electrolysis through multiphysics modeling," *Applied Energy*, vol. 313, 2022.
- [16] M. Wappler, U. Dilek and X. Lu, "Building the green hydrogen market – Current state and outlook on green hydrogen demand and electrolyzer manufacturing," *International Journal of Hydrogen Energy*, vol. 47, no. 79, pp. 33551-33570, 2022.
- [17] novaoneadvisor, "Green Hydrogen Market Size, Share & Trends Analysis Report By Technology (PEM Electrolyzer, Alkaline Electrolyzer), By Application (Power Generation, Transportation), By

Improving the performance of energy systems from renewable sources based on green hydrogen

References

- Distribution Channel, By Region- Global Industry Analysis, Share, Growth, Regional Ou,” novaoneadvisor, 2024.
- [18] Q. Hassan, A. Sameer and S. Aws Zuhair, “Green hydrogen: A pathway to a sustainable energy future,” *International Journal of Hydrogen Energy*, vol. 50, pp. 310-333, 2024.
- [19] S. Pathak, “Carefully Understanding Green Fuels – The Future of Energy,” Green Energy, 2024.
- [20] L. Wentlent, “Green Hydrogen vs Fossil Fuels: Comparing the Future of Energy,” Plug Power Resources, 2023.
- [21] Y. Himri, R. Shafiqur and A. Mostafaeipour, “Overview of the Role of Energy Resources in Algeria’s Energy Transition,” *Energies*, 2022.
- [22] S. G. P. Analytics, 2022.
- [23] A. Takilalte, S. Harrouni and J. Mora, “Forecasting global solar irradiance for various resolutions using time series models - case study: Algeria,” *Energy Sources*, pp. 1-20, 2019.
- [24] S. Rahmouni, N. Belkhir and S. Noureddine, “Prospects of hydrogen production potential from renewable resources in Algeria,” *International Journal of Hydrogen Energy*, vol. 42, no. 2, pp. 1383-1395, 2017.
- [25] H. Bahri, H. Abdelghani and R. Hegazy, “Optimal configuration and techno-economic analysis of hybrid photovoltaic/PEM fuel,” *Journal of New Materials for Electrochemical Systems*, vol. 25, no. 2, pp. 116-125, 2022.
- [26] M. Zghaibeh, B. El Manaa and P. C. Okonkwo, “Analytical model for a techno-economic assessment of green hydrogen production in photovoltaic power station case study Salalah city-Oman,” *International Journal of Hydrogen Energy*, vol. 47, no. 31, pp. 14171-14179, 2022.
- [27] H. Renaudineau, A. M. Llor and R. C. D, “Photovoltaic Green Hydrogen Challenges and Opportunities: A Power Electronics Perspective,” *IEEE Industrial Electronics Magazine*, vol. 16, no. 1, pp. 31 - 41, 2022.
- [28] M. Tao, J. A. Azzolini and E. B. Stechel, “Review—Engineering Challenges in Green Hydrogen Production Systems,” *Journal of The Electrochemical Society*, vol. 169, no. 5, 2022.
- [29] P. Xiao, W. Hu and X. Xu, “Optimal operation of a wind-electrolytic hydrogen storage system in the electricity/hydrogen markets,” *International Journal of Hydrogen Energy*, vol. 45, no. 46, pp. 24412-24423, 2020.
- [30] A. S. Al-Buraiki, “Hydrogen production via using excess electric energy of an off-grid hybrid solar/wind system based on a novel performance indicator,” *Energy Conversion and Management*, vol. 254, p. 115270, 2022.
- [31] A. Ibáñez-Rioja, P. Puranen and L. Järvinen, “Simulation methodology for an off-grid solar–battery–water electrolyzer plant: Simultaneous optimization of component capacities and system control,” *Applied Energy*, vol. 307, p. 118157, 2022.

Improving the performance of energy systems from renewable sources based on green hydrogen

References

- [32] L. Al-Ghussain, A. D. Ahmad and A. M. Abubaker, "Exploring the feasibility of green hydrogen production using excess energy from a country-scale 100% solar-wind renewable energy system," *International Journal of Hydrogen Energy*, vol. 47, no. 51, pp. 21613-21633, 2022.
- [33] M. Ozturk and I. Dincer, "System development and assessment for green hydrogen generation and blending with natural gas," *Energy*, vol. 261, p. 125233, 2022.
- [34] G. K. Karayel, N. Javani and I. Dincer, "Green hydrogen production potential for Turkey with solar energy," *International Journal of Hydrogen Energy*, vol. 47, no. 45, pp. 19354-19364, 2022.
- [35] R. Bhandari, "Green hydrogen production potential in West Africa – Case of Niger," *Renewable Energy*, vol. 196, pp. 800-811, 2022.
- [36] R. Boudries and A. Khellaf, "Techno-economic study of solar electrolytic hydrogen production at high temperature," in *2020 6th International Symposium on New and Renewable Energy (SIENR)*, Ghadaia, Algeria, 2021.
- [37] A. Gougui, A. Djafour and M. Danoune, "Field experience study and evaluation for hydrogen production through a photovoltaic system in Ouargla region, Algeria," *International Journal of Hydrogen Energy*, vol. 45, no. 4, pp. 2593-2606, 2020.
- [38] A. Al-Badi, A. A. Wahaibi and R. Ahshan, "Techno-Economic Feasibility of a Solar-Wind-Fuel Cell Energy System in Duqm, Oman," *Energies*, vol. 15, p. 5379, 2021.
- [39] Y. Gu, D. Wang and Q. Chen, "Techno-economic analysis of green methanol plant with optimal design of renewable hydrogen production: A case study in China," *International Journal of Hydrogen Energy*, vol. 47, no. 8, pp. 5085-5100, 2022.
- [40] B. Wang, X. Yu and J. Chang, "Techno-economic analysis and optimization of a novel hybrid solar-wind-bioethanol hydrogen production system via membrane reactor," *Energy Conversion and Management*, vol. 252, p. 115088, 2022.
- [41] M. Nasser, T. F. Megahed and S. Ookawara, "Performance evaluation of PV panels/wind turbines hybrid system for green hydrogen generation and storage: Energy, exergy, economic, and enviroeconomic," *Energy Conversion and Management*, vol. 267, p. 115870, 2022.
- [42] D. Banerjee, N. Kushwaha and N. P. Shetti, "Green hydrogen production via photo-reforming of bio-renewable resources," *Renewable and Sustainable Energy Reviews*, vol. 167, p. 112827, 2022.
- [43] F. Gutiérrez-Martín, L. Amodio and M. Pagano, "Hydrogen production by water electrolysis and off-grid solar PV," *International Journal of Hydrogen Energy*, vol. 46, no. 57, pp. 29038-29048, 2021.
- [44] O. Tang, J. Rehme and P. Cerin, "Levelized cost of hydrogen for refueling stations with solar PV and wind in Sweden: On-grid or off-grid?," *Energy*, vol. 241, p. 122906, 2022.
- [45] A. Grimm, W. A. d. Jong and G. J. Kramer, "Renewable hydrogen production: A techno-economic comparison of photoelectrochemical cells and photovoltaic-electrolysis," *International Journal of Hydrogen Energy*, vol. 45, no. 43, pp. 22545-22555, 2020.

Improving the performance of energy systems from renewable sources based on green hydrogen

References

- [46] Y. Zhou, R. Li and Z. Lv, "Green hydrogen: A promising way to the carbon-free society," *Chinese Journal of Chemical Engineering*, vol. 43, pp. 2-13, 2022.
- [47] M. Ramadan, "A review on coupling Green sources to Green storage (G2G): Case study on solar-hydrogen coupling," *International Journal of Hydrogen Energy*, vol. 46, no. 59, pp. 30547-30558, 2021.
- [48] M. A. Khan, I. Al-Shankiti and A. Ziani, "Demonstration of green hydrogen production using solar energy at 28% efficiency and evaluation of its economic viability," *Sustainable Energy & Fuels*, no. 4, 2021.
- [49] J. Yates, R. Daiyan and R. Patterson, "Techno-economic Analysis of Hydrogen Electrolysis from Off-Grid Stand-Alone Photovoltaics Incorporating Uncertainty Analysis," *Cell Reports Physical Science*, vol. 1, no. 10, p. 100209, 2020.
- [50] D. Concha, H. Renaudineau and M. S. Hernández, "Evaluation of DCX converters for off-grid photovoltaic-based green hydrogen production," *International Journal of Hydrogen Energy*, vol. 46, no. 38, pp. 19861-19870, 2021.
- [51] K. A. Ibrahim, M. Kim and D. Kinuthia, "High Performance Green Hydrogen Generation System," in *2021 IEEE 20th International Conference on Micro and Nanotechnology for Power Generation and Energy Conversion Applications (PowerMEMS)*, Exeter, United Kingdom, 2021.
- [52] H. Patel, S. A. Gorji and S. Mohammadshahi, "Implementation of a Lab-Scale Green Hydrogen Production System with Solar PV Emulator and Energy Storage System," in *2021 11th International Conference on Power and Energy Systems (ICPES)*, Shanghai, China, 2021.
- [53] T. B. Garlet, F. d. S. Savian and J. L. D. Ribeiro, "Unlocking Brazil's green hydrogen potential: Overcoming barriers and formulating strategies to this promising sector," *International Journal of Hydrogen Energy*, vol. 49, pp. 553-570, 2024.
- [54] Q. Hassan, A. Z. Sameen and H. M. Salman, "Energy futures and green hydrogen production: Is Saudi Arabia trend?," *Results in Engineering*, vol. 18, p. 101165, 2023.
- [55] Q. Hassan, A. K. Nassar and A. K. Al-Jiboory, "Mapping Europe renewable energy landscape: Insights into solar, wind, hydro, and green hydrogen production," *Technology in Society*, vol. 77, p. 102535, 2024.
- [56] V. Panchenko, Y. Daus and A. Kovalev, "Prospects for the production of green hydrogen: Review of countries with high potential," *International Journal of Hydrogen Energy*, vol. 48, no. 12, pp. 4551-4571, 2023.
- [57] H. He, Y. Huang and A. Nakadomari, "Potential and economic viability of green hydrogen production from seawater electrolysis using renewable energy in remote Japanese islands," *Renewable Energy*, vol. 202, pp. 1436-1447, 2023.
- [58] E. Chavez-Angel, A. Castro-Alvarez and N. Sapunar, "Exploring the Potential of Green Hydrogen Production and Application in the Antofagasta Region of Chile," *Energies*, vol. 16, no. 11, p. 4509, 2023.

Improving the performance of energy systems from renewable sources based on green hydrogen

References

- [59] D. Franzmann, H. Heinrichs and F. Lippkau, "Green hydrogen cost-potentials for global trade," *International Journal of Hydrogen Energy*, vol. 48, no. 85, pp. 33062-33076, 2023.
- [60] G. K. Karayel and I. Dincer, "Green hydrogen production potential of Canada with solar energy," *Renewable Energy*, vol. 221, p. 119766, 2024.
- [61] R. W. Makepeace, A. Tabandeh and M. Hossain, "Techno-economic analysis of green hydrogen export," *International Journal of Hydrogen Energy*, vol. 56, pp. 1183-1192, 2024.
- [62] A. Bouraiou, A. Necaibia and N. Boutassetta, "Status of renewable energy potential and utilization in Algeria," *Journal of Cleaner Production*, vol. 246, p. 119011, 2020.
- [63] D. Messaoudi, N. Settou and B. Negrou, "GIS based multi-criteria decision making for solar hydrogen production sites selection in Algeria," *International Journal of Hydrogen Energy*, vol. 44, no. 60, pp. 31808-31831, 2019.
- [64] D. Messaoudi, N. Settou and A. Allouhi, "Geographical, technical, economic, and environmental potential for wind to hydrogen production in Algeria: GIS-based approach," *International Journal of Hydrogen Energy*, vol. 50, pp. 142-160, 2024.
- [65] M. Hochberg, "Algeria charts a path for renewable energy sector development," Algerian Ministry of Energy, Algeria, 2020.
- [66] M. A. R. E. MINISTRY OF ENERGY, "PROGRAMME DE DEVELOPPEMENT DES ENERGIES RENOUVELABLES".
- [67] O. Tatarenk, "The Value of Green Hydrogen Trade for Europe," RMI, 2023.
- [68] I. R. E. A. (IRENA), "Making the breakthrough: Green hydrogen policies and technology costs," International Renewable Energy Agency, Abu Dhabi, 2021.
- [69] I. R. E. A. (IRENA), "Planning and prospects for renewable power: North Africa," IRENA, Abu Dhabi, 2023.
- [70] S. K. Singh and A. K. Tiwari, "Solar-powered hydrogen production: Advancements, challenges, and the path to net-zero emissions," *International Journal of Hydrogen Energy*, vol. 82, pp. 549-579, 2024.
- [71] S. A. Rahman, R. K. Varma and T. Vanderheide, "Generalised model of a photovoltaic panel," *IET Renewable Power Generation*, vol. 8, no. 3, pp. 217-229, 2021.
- [72] C. Lamy, "From hydrogen production by water electrolysis to its utilization in a PEM fuel cell or in a SO fuel cell: Some considerations on the energy efficiencies," *International Journal of Hydrogen Energy*, vol. 41, no. 34, pp. 15415-15425, 2016.
- [73] A. Juaidi, M. Kobari and A. Mallak, "A comparative simulation between monofacial and bifacial PV modules under palestine conditions," *Solar Compass*, vol. 8, p. 100059, 2023.
- [74] S. Panda, M. Gupta and B. Panda, "A review on advanced cooling techniques for photovoltaic panel," *Materials Today: Proceedings*, vol. 62, no. 12, pp. 6799-6803, 2022.

Improving the performance of energy systems from renewable sources based on green hydrogen

References

- [75] A. A. Bangura, M. Errouha and H. HIHI, "Modelling and Simulation of the Hybrid System PV-Wind," *Statistics, Optimization & Information Computing*, vol. 11, no. 1, 2023.
- [76] B. Yodwong, "AC-DC Converters for Electrolyzer Applications: State of the Art and Future Challenges," *Electronics*, vol. 9, no. 6, p. 912, 2020.
- [77] A. Mraoui and S. Menia, "Renewable electrolytic hydrogen potential in Algeria," *International Journal of Hydrogen Energy*, vol. 44, no. 49, pp. 26863-26873, 2019.
- [78] D. Messaoud, N. Settou and B. Negrou, "Site selection methodology for the wind-powered hydrogen refueling station based on AHP-GIS in Adrar, Algeria," *Energy Procedia*, vol. 162, pp. 67-76, 2019.
- [79] A. Gougui, "Field experience study and evaluation for hydrogen production through a photovoltaic system in Ouargla region, Algeria," *International Journal of Hydrogen Energy*, vol. 45, no. 4, pp. 2593-2606, 2020.
- [80] M. Baik, M. Hammoudi and Y. Salhi, "Hydrogen production by hybrid system and its conversion by fuel cell in Algeria; Djanet," *International Journal of Hydrogen Energy*, vol. 43, no. 6, pp. 3466-3474, 2018.
- [81] L. Bentoumi, A. Miles and Z. Korei, "Green hydrogen production by integrating a solar power plant with a combined cycle in the desert climate of Algeria," *Solar Energy*, vol. 268, p. 112311, 2024.
- [82] "NASA, "Surface meteorology and Solar Energy: A renewable energy resource web site (release 6.0)," Atmospheric Science Data Center," [Online]. Available: <https://power.larc.nasa.gov>.
- [83] A. M. Elgarahy, M. G. Eloffy and A. Hammad, "Hydrogen production from wastewater, storage, economy, governance and applications: a review," *Environ. Chem. Lett*, vol. 20, no. 6, p. 3453–3504, 2022.
- [84] M. A. Brahami, M. Dahane and M. Souier, "Sustainable capacitated facility location/network design problem: a non-dominated sorting genetic algorithm based multiobjective approach. Annals of Operations Research," *Annals of Operations Research*, vol. 311, p. 821–852, 2022.
- [85] W. Xinyi, "Comparative life cycle analysis of electrolyzer technologies for hydrogen production: Manufacturing and operations," *Joule*, vol. 8, no. 12, pp. 3347-3372, 2024.
- [86] S. Rahmouni, "Prospects of hydrogen production potential from renewable resources in Algeria," *International Journal of Hydrogen Energy*, vol. 42, no. 2, pp. 1383-1395, 2017.

Abstract

الملخص :

تهدف هذه المذكرة إلى تحسين أداء أنظمة الطاقة المتجددة المعتمدة على الهيدروجين الأخضر، مع تسليط الضوء على دوره المحوري في دعم جهود إزالة الكربون وتعزيز أمن الطاقة في الجزائر. في ظل التحول العالمي نحو مصادر طاقة مستدامة لمواجهة تغير المناخ ونضوب احتياطيات الوقود الأحفوري، يبرز الهيدروجين الأخضر كحامل طاقة مبتكر يوفر بديلاً نظيفاً وفعالاً للوقود التقليدي. تعتمد الدراسة على الاستفادة من الموارد الطبيعية الغنية في الجزائر، خاصةً الطاقة الشمسية الفوتوفولطية، لتسليط الضوء على الإمكانيات الكبيرة التي تملكها البلاد لتصبح ركيزة أساسية في اقتصاد الهيدروجين الأخضر العالمي.

توظف المذكرة أدوات نمذجة ومحاكاة متقدمة مثل HOMER Pro و MATLAB Simulink لتقييم إنتاجية الأنظمة الشمسية وكفاءة عمليات التحليل الكهربائي وعمل خلايا الوقود تحت ظروف تشغيل متنوعة. كما تستعرض الدراسة إمكانية استخدام تقنيات تحليل مياه البحر ومعالجة مياه الصرف الصحي كمصادر مائية مستدامة لإنتاج الهيدروجين، مما يساهم في تعزيز الجدوى الاقتصادية والبيئية للمشاريع، حيث يتناول الفصل الأول الأزمة الطاقوية العالمية ودور الهيدروجين الأخضر في تقديم حلول مبتكرة لمواجهة هذه التحديات، بينما يقدم الفصل الثاني مراجعة شاملة للأبحاث الدولية والإقليمية المتعلقة بإنتاج الهيدروجين الأخضر مع إبراز أهمية التعاون الدولي، كما يركز الفصل الثالث على التحديات الفنية والاقتصادية والبيئية، مقدماً حلولاً مبتكرة لتحسين أداء أنظمة الطاقة القائمة على الهيدروجين الأخضر، حيث تشير النتائج إلى فرص واعدة لتنويع الاقتصاد الجزائري، وتعزيز أمن الطاقة، وخلق فرص عمل جديدة، مما يواكب التزامات الجزائر الدولية في مكافحة تغير المناخ.

تسعى هذه الدراسة إلى ردم الفجوة بين البحث النظري والتطبيق العملي، لتطوير مستقبل طاقتي منخفض الكربون ومستدام.

Abstract :

This dissertation aims to improve the performance of renewable energy systems based on green hydrogen, emphasizing its pivotal role in supporting decarbonization efforts and enhancing energy security in Algeria. Amid a global transition towards sustainable energy sources to tackle climate change and dwindling fossil fuel reserves, green hydrogen emerges as an innovative energy carrier, offering a clean and efficient alternative to traditional fuels. The study capitalizes on Algeria's abundant natural resources, particularly photovoltaic solar energy, highlighting the country's significant potential to become a key player in the global green hydrogen economy.

The research employs advanced modeling and simulation tools (such as HOMER Pro and MATLAB Simulink) to assess photovoltaic productivity, electrolysis performance, and fuel cell efficiency under diverse operating conditions. Additionally, the study explores the feasibility of utilizing seawater electrolysis and wastewater treatment as sustainable water

Improving the performance of energy systems from renewable sources based on green hydrogen

Abstract

sources for hydrogen production, thereby enhancing the economic and environmental viability of the projects.

The first chapter examines the global energy crisis and the innovative role of green hydrogen. The second chapter provides a comprehensive review of international and regional research on green hydrogen production, underscoring the importance of international collaboration to boost this sector in Algeria. The third chapter focuses on the technical, economic, and environmental challenges, offering innovative solutions to optimize the performance of energy systems based on green hydrogen.

The findings reveal promising opportunities for diversifying Algeria's economy, strengthening energy security, and creating new jobs, in line with Algeria's international commitments to combating climate change. This study bridges the gap between theoretical research and practical application, paving the way for a resilient, low-carbon, and sustainable energy future.

Résumé :

Cette thèse vise à améliorer la performance des systèmes énergétiques renouvelables basés sur l'hydrogène vert, en mettant en avant son rôle central dans la décarbonation et le renforcement de la sécurité énergétique en Algérie. Dans un contexte de transition mondiale vers des sources d'énergie durables pour faire face aux défis du changement climatique et à l'épuisement des réserves de combustibles fossiles, l'hydrogène vert apparaît comme un vecteur énergétique innovant, offrant une alternative propre et efficace aux énergies traditionnelles. L'étude s'appuie sur les ressources naturelles abondantes de l'Algérie, notamment l'énergie solaire photovoltaïque, pour illustrer le potentiel du pays à devenir un acteur majeur dans l'économie mondiale de l'hydrogène vert.

La recherche utilise des outils avancés de modélisation et de simulation (tels que HOMER Pro et MATLAB Simulink) afin d'évaluer la productivité photovoltaïque, la performance de l'électrolyse et l'efficacité des piles à combustible dans diverses conditions d'exploitation. Par ailleurs, l'étude explore l'utilisation de l'électrolyse de l'eau de mer et du traitement des eaux usées comme sources d'eau durables pour la production d'hydrogène, renforçant ainsi la viabilité économique et environnementale des projets.

Le premier chapitre aborde la crise énergétique mondiale et le rôle innovant de l'hydrogène vert. Le deuxième chapitre offre une revue complète des recherches internationales et régionales sur la production d'hydrogène vert, soulignant l'importance de la coopération internationale pour dynamiser ce secteur en Algérie. Le troisième chapitre se concentre sur les

Improving the performance of energy systems from renewable sources based on green hydrogen

Abstract

défis techniques, économiques et environnementaux, proposant des solutions innovantes pour améliorer les performances des systèmes énergétiques basés sur l'hydrogène vert.

Les résultats mettent en lumière des opportunités prometteuses pour diversifier l'économie algérienne, renforcer la sécurité énergétique et créer de nouveaux emplois, en adéquation avec les engagements internationaux de l'Algérie en matière de lutte contre le changement climatique. Cette recherche ambitionne de combler le fossé entre la théorie et la pratique afin de bâtir un avenir énergétique résilient et à faible émission de carbone.