

People's Democratic Republic of Algeria
Ministry of Higher Education and Scientific Research



N°:.....

University Mohamed Boudiaf - M'Sila
Faculty of Technology
Department of Electronics

A Dissertation
Submitted to the Department of Electronics
in Partial Fulfillment of the Requirements for the
Master's Professional Degree

Domain: Sciences and Technology
Stream: Telecommunications
Option: Telecommunications Engineering

Title of the Dissertation

***Optimization of Transmission Channel in a GSM
Telecommunications Network***

Prepared by:
- Mohammed Nizar BOUNIF
- Toufik BEN RAYA

Supervised by:
Dr. Mohamed SAHED
Mr. Abdelouadoud LOUKRIZ

Defended on 23/06/2022, in front of the examination board composed of:

El Hadi KENANE	University of M'Sila	Chairperson
Mohamed SAHED	University of M'Sila	Supervisor
Abdelouadoud LOUKRIZ	ATM Mobilis	Co-supervisor
Ali KHALFA	University of M'Sila	Examiner

Academic Year: 2021/2022

بِسْمِ اللَّهِ الرَّحْمَنِ الرَّحِيمِ

Dedications

This work is completely dedicated to my respectful parents, words cannot describe how much they helped me through my way of graduating. They are always inspiring me and has never left me in need, for my siblings, especially my sister for caring and helping writing this dissertation; for all my family and friends.

Nizar

Dedications

*I dedicate this humble work to my dear mother to her sacrifices, to my dear father
To my brothers, to my sisters and all family members, to all my friends
to all teachers in the Department of Electronics, especially in communications engineering.*

Toufik

Acknowledgments

We would like to express our special thanks of gratitude to our supervisor Dr. Mohamed SAHED and co-supervisor Mr. Abdelouadoud LOUKRIZ for providing guidance and feedbacks throughout this dissertation, for their support, time, encouragement and patience.

Our thanks are also addressed to Dr. El Hadi KENANE for being the chairperson of this dissertation and for Dr. Ali KHALFA for being the examiner. We would like to thank them for their valuable comments, suggestions and critical reading of this manuscript.

We wish express our deep gratitude, as well, to all people who helped us to complete this work. Our special thanks also go to our friends for their assistance during this study.

Abstract

We treat through this dissertation the problem of channel optimization in 2G GSM network in M'Sila city. This dissertation is a combination of theoretical study and practical activities which are carried out on site. The objective behind this study was made in order to understand how to optimize a cellular network by taking into account different parameters that come into play in the optimization of this specific network. At the beginning, this dissertation gives a brief description of the characteristics of the GSM network, from the point of view of constitution, operation and propagation of radio waves. After that, the cellular concept and the KPIs, which are key factors in the optimization of a cellular network, have been also discussed. In collaboration with ATM Mobilis maintenance team, we propose an optimization procedure by augmenting E1 in order to overcome the degradation in the performance of GSM network, the bad quality of services (calls set-up problems, calls cuts, ... etc) in one of the biggest streets in M'Sila city. In doing that, we used the WEBLCT software developed by Huawei. Obtained results show the efficiency of the proposed procedure and the quality of services is remarkably enhanced.

Key words: 2G, GSM, Optimization, KPI, WEBLCT.

Table of contents

Acronyms	iii
List of figures	v
List of tables	vi
Introduction	1
A. Background	2
B. Motivation	3
C. Problem statement	3
Chapter 1 : An Overview of the GSM Systems	4
1.1 Introduction	5
1.2 History of GSM networks	5
1.3 Cellular systems	7
1.4 Architecture of GSM networks	7
1.4.1 Mobile Station.....	7
1.4.2 Network Switching System.....	8
1.4.3 Base Station System.....	9
1.4.4 Operation and Support System	10
1.5 GSM frequency bands	10
1.6 Geographical area of GSM networks	10
1.7 Functions of GSM networks	11
1.7.1 Transmission function.....	11
1.7.2 Radio resources management function	11
1.7.3 Mobility management function	12
1.7.4 Communication management function	12
1.7.5 Operation, administration and maintenance function	12
1.8 Interfaces in GSM networks.....	13
1.8.1 Air Interface	13
1.8.2 U _m radio interface	13
1.8.3 A _{bis} interface.....	13
1.8.4 A interface.....	13
Chapter 2 : Concepts of GSM Network Optimization.....	15
2.1 Introduction	16
2.2 Radio Network Planning and Optimization	16

2.3 Basics of Radio Network Planning	16
2.3.1 Scope of Radio Network Planning.....	16
2.3.2 Concepts of Cell, Cluster and Sector	17
2.3.3 Channel Configuration in GSM	19
2.3.3 Radio Network Planning Process.....	19
2.4 Basics of Radio Network Optimization	20
2.4.1 Key Performance Indicators	21
2.4.2 Network Performance Monitoring	21
2.4.3 Network Performance Assessment	22
2.5 Transmission Network Optimization	22
2.5.1 Basics of Transmission Network Optimization	22
2.5.2 Transmission Network Optimization Process.....	22
2.6 Core Network Optimization	23
2.6.1 Basics of the Optimization Process.....	23
2.6.2 Data Collection and Analysis.....	23
2.6.3 Core Network Optimization Plan.....	24
2.7 Conclusion.....	25
Chapter 3 : Optimization of GSM Network Services in M'Sila City	26
3.1 Introduction	27
3.2 Analysis the zone of study	27
3.3 Description of the optimization tool and procedure	29
3.3.2 Presentation of the optimization tool	29
3.3.3 Optimization procedure	31
3.4 Optimization of KPI's in M'Sila city	35
3.5 Conclusion.....	36
Conclusion and future works	38
Appendix	40
References	45
Abstract.....	47

Acronyms

2G	2nd generation
3G	3rd generation
4G	4th generation
5G	5th generation
AUC	Authentication Center
BCCH	Broadcast control channel
BSC	Base Station Controller
BSS	Base station system
BTS	Base transceiver station
BTS	Base transceiver station
CC	Call Control
CEPT	Conference Européenne des Postes et Telecommunications
CGI	Cell Global Identity number
CISCO	Commercial & Industrial Security Corporation
CM	Communication Management
EIR	Equipment Identity Register
ETSI	European Telecommunications Standards Institute
GSM	Global System for Mobile Communications
HLR	Home Location Register
IMSI	International Mobile Subscriber Identity
ISDN	Integrated services digital network
KPI	Key performance indicator
LA	Location Area
LAI	Location Area Identity
LTE	Long Term Evolution
ME	Mobile Equipement
MM	Mobility Management
MS	Mobile station
MSC	Mobile services Switching Center
NSS	Network switching system
OAM	Operation, Administration and Maintenance
OMC	Operations and maintenance center
OSS	Operation and support system
PIN	Personal Identification Number
PLMN	Public Land Mobile Network

PoI	Parameters of internet
RF	Radio frequency
RR	Radio Resources management
SDH	Synchronous Digital Hierarchy
SIM	The Subscriber Identity Module
SMS	Short Message Services
SS	Supplementary Services management
TCH	Traffic channel
TDMA	Time division multiple access
UMTS	Universal Mobile Telecommunications System
VLR	Visitor Location Register
WDM	Wavelength Division Multiplex

List of figures

Figure 1.1 - Basic architecture of the GSM network.....	9
Figure 1.2 - GSM network area.....	11
Figure 2.1 - Scope of radio network planning [6]	16
Figure 2.2 - Hexagonal cell	17
Figure 2.3 - Cell shapes.....	17
Figure 2.4 - Cell cluster (a) Cluster of three Cells (b) Cluster of seven cells.....	18
Figure 2.5 - Illustration of 120° sectorization (a) Cluster of three Cells (b) Cluster of seven cells	18
Figure 2.6 - Radio Network Planning Process	20
Figure 2.7 - Radio network optimization	21
Figure 3.1 - Geographical map of the position of the degraded site 28669 and the farend site 28501 .	27
Figure 3.2 - R9109 Line before Optimization Operation	28
Figure 3.3 - T66008 line before optimization operation	29
Figure 3.4 - Site overview (a) Rooftop pole (b) Outdoor BTS cabinet, (c) TX and radio devices, and (d) Antenna 0.6 m with ODUs	31
Figure 3.5 - Overview of RTN 910 (28669 side) using WebLCT Software	32
Figure 3.6 - E1 electrical interconnection in the site 28669.....	33
Figure 3.7 - SDH/PDH Service Management interface	33
Figure 3.8 - Steps of create cross connection.....	34
Figure 3.9 - Resulting E1 software cross connection.....	34
Figure 3.10 - R9109 Before and after optimization operation	35
Figure 3.11 - T66008 Before and after optimization.....	36

List of tables

Table 1.1 - Key events and milestones in GSM networks history	6
Table 2.1 - Control channels	19

Introduction

A. Background

In wireless communication, it is well known that mobile users communicate with a base station via a wireless channel. This is one of the main reasons behind the huge success of wireless communication. For instance, the Global system for mobile communication (GSM) is well suited to handle mobility very well. This system is a kind of cellular networks, which are a globally accepted standard for digital cellular communication.

A cellular network can control mobility in one of two ways. First, when the mobile station (MS) is in idle mode, which occurs when there is no active call or when it is switched off. In this situation, the network uses location management to keep track of the MS [1]. Second, when an active mobile device moves into a network's coverage region. This will result in circumstances where the MS departs the service area of a single cell, necessitating the use of a feature that allows an ongoing call to be transferred from one physical channel to another without being dropped; this feature is known as handover.

One of the most basic characteristics of cellular communication is handover. Horizontal handover occurs when two networks of the same radio access technology (GSM to GSM) communicate with each other, and vertical handover occurs when two networks or radio access technologies communicate with each other (e.g., 3G to LTE). Furthermore, there are two varieties of horizontal handover: a hard changeover, in which the call is handled by just one connection at any one moment, which is the type used in GSM, and the default in LTE. The soft handover is the second type, in which the MS is connected to multiple cells at once during the handover procedure [2].

Certain conditions must be completed before the handover can take place. The received signal level and speech quality are examples of such conditions in the radio environment. It can also be a network criterion, such as the amount of mobile traffic. When an active MS sends measurement reports to its serving cell on a regular basis, the necessity for a handover is determined [3].

These handover-initiation-conditions are represented in a network as customizable parameters at several network levels, some are system parameters, some are cell parameters, and others are cell-to-cell parameters. Setting and changing all these parameters for optimization reasons, in a network with thousands of cells, can be difficult to manage and may take significant amount of labor time. More work is now being directed toward newer radio technology. As a result, optimizing the GSM network that needs limited human resources is critical for the mobile operators.

B. Motivation

Despite the rapid advances of radio access technologies, including the launch of 3G, 4G, 5G (in some developed countries) and the current preparations for 6G, which is scheduled to be commercially accessible by 2026, GSM (2G) is still important, particularly for voice traffic; according to CISCO, 55% of connected devices are 2G/3G linked, but by the end of 2023, these will decline to 29%. According to the latest Cisco Annual Internet Report [4]. With the present trend of data consumption, other portions of the network are becoming more vital and crucial to the main business. Given that voice service is not delay tolerant, the GSM component of the network is highly important to any operator. As a result, directing as much effort and time away from the GSM section of the network as possible is very recommended.

In order to achieve the best performance, service providers have to monitor and optimize their network continuously. This dissertation is motivated by the requirement to present an optimization procedure that may improve the quality of services based on some network parameters in order to keep performance metrics within acceptable ranges.

Motivated by this need, this dissertation is aiming to apply an optimization procedure in collaboration with ATM Mobilis maintenance team, by making the decision of augmenting E1. The aim of this procedure is to keep the subscriber satisfied with the delivered quality of services by analyzing and reducing the POI congestion. This procedure is used in order to fix many issues related to degradation of performances and services quality in GSM network in one of the biggest streets in M'Sila city.

C. Problem statement

Automation of operations can minimize operational problems and save costs and time. In our case, the degradation in performance of the GSM network and the bad quality of services in M'Sila city are the main issues we tried to solve. In order to achieve our goal, we introduce an optimization procedure in association with ATM Mobilis maintenance team.

Throughout this dissertation, we will attempt to answer the following questions:

- How can our procedure optimize the service quality based on network status and certain KPIs?
- How can the lack of idle timeslots yield a big number of unsuccessful application attempts?

Chapter 1 : An Overview of the GSM Systems

1.1 Introduction

This chapter provides an overview and description of the most important features of the Global System for Mobile (GSM), which is a digital cellular communications system. It was considered in order to model a common European mobile phone standard, but it has quickly gained worldwide acceptance. The GSM was designed to be compatible with ISDN services.

The chapter discusses essentially the architecture of GSM network, its functions and the different interfaces and protocols used between GSM entities.

1.2 History of GSM networks

In the early 1970s, the idea of cell-based mobile radio systems appeared at Bell Laboratories in the United Stat of America. However, mobile cellular systems, on the other hand, did not become commercially available until the 1980s. Analog cellular telephone systems grew rapidly in Europe during the early 1980s, particularly in Scandinavia and the United Kingdom. Cellular systems are still one of the most rapidly increasing telecommunications technologies today [5].

However, at the early stages of cellular systems, each country established its own system, which was undesirable because the mobile equipment was allowed to operate only within the boundaries of each country and the market for each equipment was limited.

In order to address these issues, the *Conference Européenne des Postes et Telecommunications* (CEPT) established the Groupe Spécial Mobile (GSM) in 1982 to design a pan-European mobile cellular radio system (GSM stands for Global System for Mobile Communications these days). The standardized system required to meet the following criteria [5]:

- Spectrum efficiency
- International roaming
- Low mobile and base stations costs
- Good subjective voice quality
- Compatibility with other systems such as ISDN (Integrated Services Digital Network)
- Ability to support new services

Unlike previous cellular systems, which were built using analog technology, the GSM system was built using digital technology.

In 1989, the European Telecommunications Standards Institute (ETSI) took up responsibility for GSM specifications from the CEPT. These specifications will then standardize the system, ensuring that the various pieces of the GSM system function together

properly. After that, the first phase of the GSM specifications was published in 1990, but commercial use of GSM did not start until 1991. Table 1-1 shows the most significant events in the evolution of the GSM system [5].

In view of its evolution, GSM technology is no longer just a European standard, but rather has been operated and planned in more than 100 countries around the world. The following points show the quick and growing acceptance of the GSM system [5]:

- 1.3 million GSM subscribers and 100 operators worldwide in the beginning of 1994.
- Over 5 million GSM subscribers worldwide in the beginning of 1995.
- Over 10 million GSM subscribers only in Europe by December 1995.
- Over 50 million GSM subscribers and 200 operators from nearly 100 countries in 1996.
- Over 50 million GSM subscribers in 1998.

Table 1.1 - Key events and milestones in GSM networks history

Year	Milestones
1982	CEPT established Groupe Speciale Mobile GSM to develop pan-European cellular mobile system standards.
1985	A basic set of recommendations to be generated was adopted by the group.
1986	Field tests were conducted to determine which techniques should be used for the new system.
1987	The TDMA method was chosen as the primary access method for GSM. Although frequency division is utilized between channels, time division is employed for each frequency channel. Mobile operators from 12 countries also signed the Initial memorandum of understanding this year.
1988	The GSM system is being validated.
1989	The GSM standards will be managed by ETSI, the European Telecommunications Standards Institute.
1990	The first phase of the GSM standards has been released.
1991	The GSM service was officially launched.
1993	GSM services start outside of Europe with coverage of main roads.
1995	Phase 2 GSM specifications have been issued, and rural areas have been covered by GSM networks.

1.3 Cellular systems

In a cellular system, the covering area of an operator is divided into cells. A cell is the area covered by a single transmitter or a small group of transmitters. Because a country's population density varies so much, multiple sorts of cells are used: macrocells, microcells, selective cells and umbrella cells. The power of the transmitter determines the size of a cell. The number of cells is grouped into a cluster. This number must be determined so that the cluster can be repeated continuously within the covering area of an operator. A typical cluster contains 4, 7, 12 or 21 cells [5].

The idea behind cellular systems is to use low-power transmitters in order to allow for efficient reuse of the frequencies. Indeed, if the transmitters are extremely powerful, the frequencies cannot be reused for hundreds of kilometers since they are limited by the transmitter's coverage area.

The frequency band assigned to a cellular mobile system is distributed across a group of cells. This distribution is repeated in the whole covering area of an operator. Each group of cells that makes up an operator's coverage area can then utilize the entire number of available radio channels. The frequencies utilized in one cell will be reused in other distant cells. To avoid interference, the distance between cells using the same frequencies must be sufficient. The possibility of reusing same frequencies in different cells will increase significantly the capacity in number of users.

1.4 Architecture of GSM networks

The GSM network is divided into four major systems: the Mobile Station (MS), the network switching system (NSS), the base station system (BSS), and the operation and support system (OSS). The basic GSM network elements are shown in Figure 1.1.

1.4.1 Mobile Station

The Mobile Station (or Mobile Equipment) is made up of two main elements:

- **Mobile Equipment (ME), Mobile Unit or Terminal:** Terminals are classified according to their power and use into different types:
 - ✓ The fixed terminals are the ones installed in automobiles. Their maximum output power is limited to 20 W.
 - ✓ The portable terminals can also be implanted in vehicles. Their maximum allowed output power is 8W.
 - ✓ The handheld terminals have had the most success due to their low weight and volume. Up to 2 W can be emitted by these terminals. The advancement of

communication technology has allowed the maximum allowed power to be reduced to 0.8 W.

- **The Subscriber Identity Module (SIM):** The SIM is a smart card that identifies the terminal. By inserting the SIM card into the terminal, the user can access all of the subscribed services. The SIM card is required to operate the terminal. A four-digit Personal Identification Number (PIN) is used to protect the SIM card. In order to identify the subscriber to the system, the SIM card contains some parameters of the user such as its International Mobile Subscriber Identity (IMSI). Another advantage of the SIM card is the mobility of the users. In fact, the only element that personalizes a terminal is the SIM card. Therefore, the user can have access to its subscribed services in any terminal using its SIM card.

1.4.2 Network Switching System

The network switching system (NSS) is responsible for performing call processing and subscriber-related functions. The switching system includes the following functional units:

- **Home Location Register (HLR):** The HLR is a database used for storage and management of subscriptions. The HLR is considered the most important database, as it stores permanent data about subscribers, including a subscriber's service profile, location information, and activity status. When an individual buys a subscription from one of the PCS operators, he or she is registered in the HLR of that operator.
- **Mobile services Switching Center (MSC):** The MSC performs the telephony switching functions of the system. It controls calls to and from other telephone and data systems. It also performs such functions as toll ticketing, network interfacing, common channel signaling, and others.
- **Visitor Location Register (VLR):** The VLR is a database that contains temporary information about subscribers that is needed by the MSC in order to service visiting subscribers. The VLR is always integrated with the MSC. When a mobile station roams into a new MSC area, the VLR connected to that MSC will request data about the mobile station from the HLR. Later, if the mobile station makes a call, the VLR will have the information needed for call setup without having to interrogate the HLR each time.
- **Authentication Center (AUC):** A unit called the AUC provides authentication and encryption parameters that verify the user's identity and ensure the confidentiality of each call. The AUC protects network operators from different types of fraud found in today's cellular world.

- **Equipment Identity Register (EIR):** The EIR is a database that contains information about the identity of mobile equipment that prevents calls from stolen, unauthorized, or defective mobile stations. The AUC and EIR are implemented as stand-alone nodes or as a combined AUC/EIR node.

1.4.3 Base Station System

All radio-related functions are performed in the base station system (BSS), which consists of base station controllers (BSCs) and the base transceiver stations (BTSs).

- **Base Station Controllers (BSC):** The BSC provides all the control functions and physical links between the MSC and BTS. It is a high-capacity switch that provides functions such as handover, cell configuration data, and control of radio frequency (RF) power levels in base transceiver stations. A number of BSCs are served by an MSC.
- **Base Transceiver Stations (BTS):** The BTS handles the radio interface to the mobile station. The BTS is the radio equipment (transceivers and antennas) needed to service each cell in the network. A group of BTSs are controlled by a BSC.

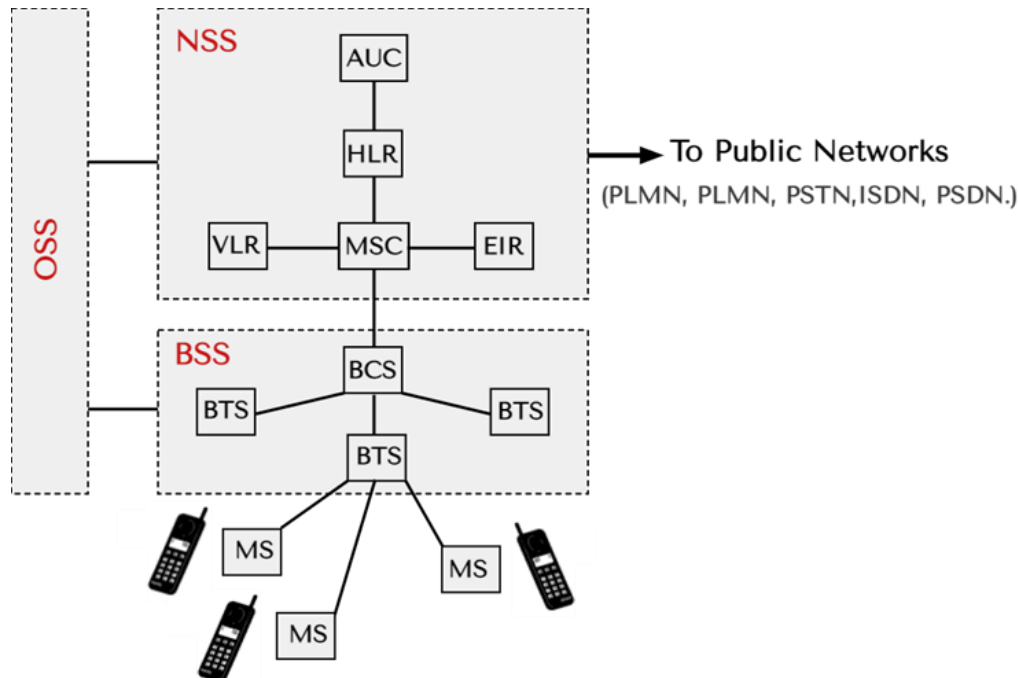

Figure 1.1 - Basic architecture of the GSM network

1.4.4 Operation and Support System

The operations and maintenance center (OMC) is connected to all equipment in the network switching system and to the BSC. The implementation of OMC is called the operation and support system (OSS). The OSS is the functional entity from which the network operator monitors and controls the system. The purpose of OSS is to offer the customer cost-effective support for centralized, regional, and local operational and maintenance activities that are required for a GSM network. An important function of OSS is to provide a network overview and support the maintenance activities of different operation and maintenance organizations.

1.5 GSM frequency bands

The GSM system is a frequency- and time-division system, with a carrier frequency and a time slot number assigned to each physical channel. In Algeria, the GSM system uses two bands of frequencies: 900 MHz and 1800 MHz, which are referred to as the GSM-900 and DCS-1800 systems, respectively. In the GSM-900 band, 124 radio carriers have been defined and assigned in two sub-bands of 25 MHz each in the 890–915 MHz and 935–960 MHz frequency ranges, with channel widths of 200 kHz. In the 1710–1785 MHz and 1805–1880 MHz ranges, there are two 75 MHz sub-bands for DCS-1800.

1.6 Geographical area of GSM networks

The GSM network consists of geographic areas. Figure 1.2 shows the different areas that form the GSM network [5].

A cell, as previously stated, corresponds to the radio coverage of a BTS and is recognized by a Cell Global Identity number (CGI). A Location Area (LA) is a set of cells served by a single MSC/VLR and is identified by a Location Area Identity (LAI) number. The MSC/VLR area is defined as a collection of location areas controlled by the same MSC/VLR. A Public Land Mobile Network (PLMN) is the area served by one network operator.

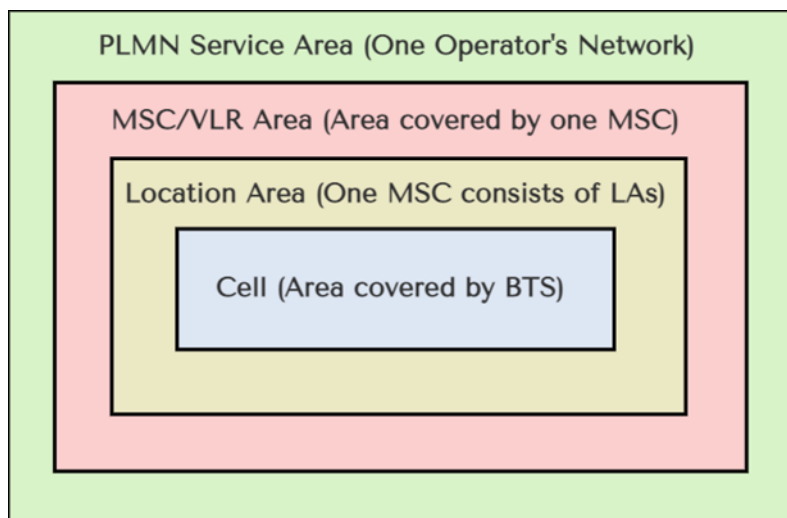

Figure 1.2 - GSM network area

1.7 Functions of GSM networks

In this paragraph, we will focus on various functions to fulfil by a GSM network rather than its physical components. A GSM network performs the following five main functions: Transmission, Radio Resources management (RR), Mobility Management (MM), Communication Management (CM) and Operation, Administration and Maintenance (OAM).

1.7.1 Transmission function

Two sub-functions make up the transmission function:

- The first is concerned with the tools required for the transmission of user information.
- The second is related to the tools needed for the transmission of signaling information.

The transmission functions are not strongly related to all components of the GSM network. For instance, the MS, the BTS and the BSC, among others, are extremely associated with these functions. However, other components, such as the HLR, VLR or EIR registers, are only concerned with transmission for their signaling needs with other GSM network components.

1.7.2 Radio resources management function

Radio Resources Management (RR) function is responsible for establishing, maintaining, and releasing communication links between mobile stations and the MSC. The

mobile station and the base station are the components that are most concerned with the RR function. The MSC, which is in charge of handovers, is also concerned with the RR function.

The RR is also in charge of frequency spectrum management and the reaction of the network to changing radio environment conditions. Some of the most important RR practices that ensure its accountability are: Channel assignment, change and release; Handover; Frequency hopping; Power-level control; Discontinuous transmission and reception and Timing advance.

1.7.3 Mobility management function

The Mobility Management (MM) function is responsible of all the aspects related to the mobility of the user, including the location management and the authentication and security.

1.7.4 Communication management function

The Communication Management (CM) function is responsible for Call Control (CC), Supplementary Services management (SS), and Short Message Services management (SMS).

- **Call Control (CC):** The CC is in charge of call establishment, maintenance, and release, as well as service type selection. Call routing is one of the most critical responsibilities of the CC. In order to reach a mobile subscriber, a user dials the Mobile Station Integrated Services Digital Network (MSISDN) number which includes: a country code, a national destination code identifying the operator of subscriber and a code corresponding to the HLR of the subscriber.
- **Supplementary Services management (SS):** An SS modifies or supplements a basic telecommunication service, such as forwarding calls to another number. As a result, the SS cannot be offered to a customer as a stand-alone service, instead it must be offered in conjunction with a basic telecommunication service.
- **Short Message Services management (SMS) :** To keep these services running, a GSM network communicates with a message center via the two: the SMS-GMSC for Mobile Terminating Short Messages (SMS-MT/PP) and the SMS-IW MSC for Mobile Originating Short Messages (SMS-MO/PP).

1.7.5 Operation, administration and maintenance function

The Operation, Administration and Maintenance (OAM) function enables the operator to monitor and control the system as well as to change the configuration of the elements of the system. It may be noted that the OAM includes not only the OSS, but also the BSS and NSS.

1.8 Interfaces in GSM networks

1.8.1 Air Interface

The air interface is the most significant and central interface in every mobile system. The relevance of this interface arises from the fact that it is the only interface that the mobile subscriber is exposed to and that the quality of this interface is a critical factor for the success of the mobile network. The quality of this air interface primarily depends upon the efficient usage of the frequency spectrum that is assigned to it [6].

1.8.2 U_m radio interface

The U_m radio interface (between MS and BTS) is the air interface which is most important in any mobile radio system. The physical layer interfaces to the data link layer and radio resource management sublayer in the MS and BS and to other functional units in the MS and network subsystem (which includes the BSS and MSC) for supporting traffic channels. The physical interface comprises a set of physical channels accessible through FDMA and TDMA multiplexing access techniques.

The U_m radio interface uses the Link Access Protocol on Dm channel (LAPDm). This protocol is a modified version of the data link layer protocol LAPD (Link Access Protocol in the D channel). The modifications make it suitable for transmission across a radio interface. It is used in GSM to support the transport of information between the mobile and the network.

1.8.3 A_{bis} interface

The A_{bis} interface is a BSS internal interface linking the BTS and the BSC. The Abis interface allows control of the radio equipment and radio frequency allocation in the BTS. The transmission rate is 2.048 Mbps, divided into 32 channels of 64 Kbps each. The compression techniques used by GSM combine up to eight GSM traffic channels into a single 64Kbps channel. The Abis-interface is regarded as proprietary, which leads to variations in the Layer 2 protocol between manufacturers, as well as to different channel configurations. The consequence is that, normally, a BTS from manufacturer A cannot be used with a BSC from manufacturer B [6].

1.8.4 A interface

This interface exists between the core network and the access network, specifically between the MSC/VLR and the BSS. The A interface provides means for BSS management, call control and mobility management. This interface consists of one or more PCM links each having a capacity of 2048 Mbps. The signaling transport uses Message Transfer Part (MTP)

and Signaling Connection Control Part (SCCP). There are two parts of the A interface: one from the BTS to the TRAU where the transmitted payload is compressed; and the other between the TRAU and MSC where all the data is uncompressed. The TRAU is typically located between the MSC and BSC and should be taken into consideration when dealing with this interface [6].

***Chapter 2 : Concepts of GSM Network
Optimization***

2.1 Introduction

Since the early days of GSM development, the GSM system network planning has undergone significant changes in order to meet the ever-increasing demand from operators and mobile customers with capacity and coverage difficulties. Because of its proximity to mobile users, radio network planning is possibly the most crucial aspect of the entire network architecture. Before going into the process's details, let's take a look at some fundamental difficulties.

2.2 Radio Network Planning and Optimization

Since its beginning, the GSM system network planning has been extensively modified to meet the increasing demand from operators and mobile customers with capacity and coverage difficulties. Because of its proximity to mobile users, radio network planning is possibly the most crucial aspect of the entire network architecture [6].

2.3 Basics of Radio Network Planning

2.3.1 Scope of Radio Network Planning

As shown in Figure 2.1, the radio network consists of the BTS, the MS and the interface between them. This is the section of the network that is directly connected to the mobile user, for this reason it is very important. The base station should be able to communicate with the mobile station within a defined coverage area while preserving call quality standards. The connection between these two-ends is ensured via a radio link which should be able to provide sufficient capacity and coverage [6].

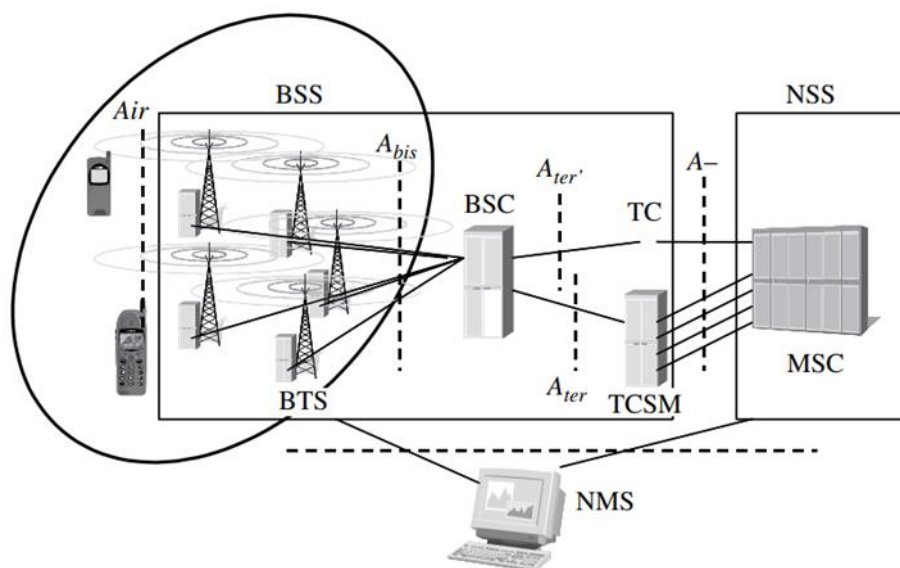

Figure 2.1 - Scope of radio network planning [6]

2.3.2 Concepts of Cell, Cluster and Sector

- **Cell:** A cell is a radio coverage area provided by a single BTS antenna system (see Figure 2.2). A hexagon can represent a cell, which is the smallest building element in a mobile network. There are two types of cells:

1. Omni-directional cell (or omniscell): An omni-directional cell (or omniscell) is served by a BTS with an antenna that broadcasts equally in all directions (360 degrees).

2. Sector cell: A sector cell is the coverage area of an antenna that only transmits in one direction. This might be 120 degrees or 180 degrees in a comparable omni-directional cell, for example. With a collection of BTS's at a site supporting more than one of these sector cells, phrases like two-sectored sites and, more typically, three-sectored sites come to mind [7, 8].

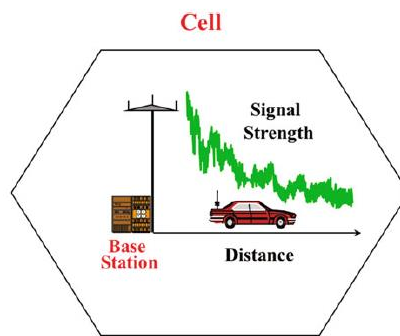

Figure 2.2 - Hexagonal cell [8]

The hexagonal shape of the cell is a man-made structure. This is the shape that is closest to the circular shape, which symbolizes the ideal coverage of the base station antenna's power transmission. The circular shapes are troublesome because they have overlapped covering zones. In actuality, their shapes resemble the one represented in Figure 2.5. In a real network, cells will have non-geometrical shapes, with some places lacking the appropriate signal strength for various reasons [8].

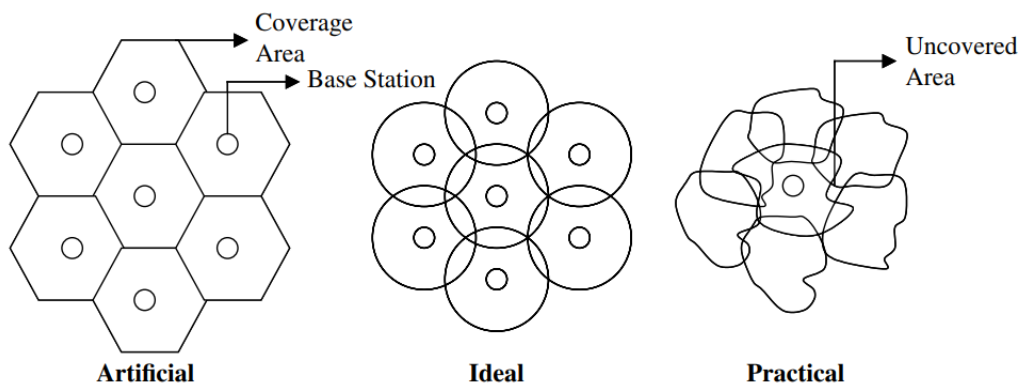

Figure 2.3 - Cell shapes [6]

- **Cluster:** Clusters are patterns of cells formed by putting together groups of frequencies. A cluster is a collection of cells in which all of the available frequencies have been used just once (See Figure 2.3). Interference may be a problem because neighboring clusters can use the same frequencies. As a result, the maximum frequency reuse distance must be maintained. The frequency reuse distance should, however, be kept as short as feasible to enhance capacity [8].

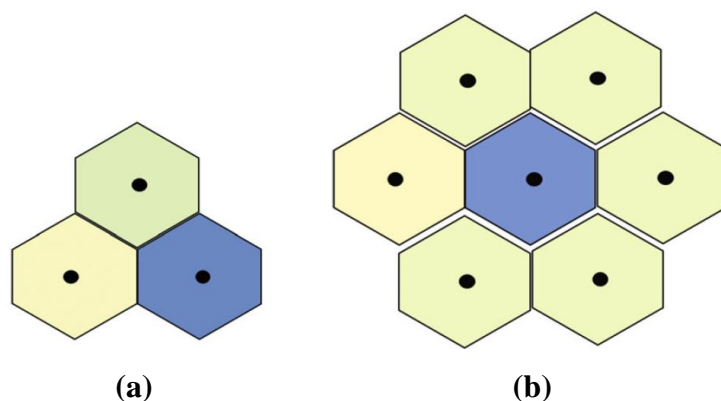

Figure 2.4 - Cell cluster (a) Cluster of three Cells (b) Cluster of seven cells [8]

- **Sector:** In general, a cell is divided into sectors. For example, a 120° sectorization is achieved by dividing a cell into three sectors, 120° each, as shown in Figure 2.5a. Each sector is treated as a logical cell, where directional antennas are used in each sector. Figure 2.5b shows an alternate representation, where each sector is represented by a hexagon. This configuration is known as tri-cellular plan [8]. Both configurations are conceptually identical, while the latter is convenient for channel assignment. Each sector uses a set of different channels.

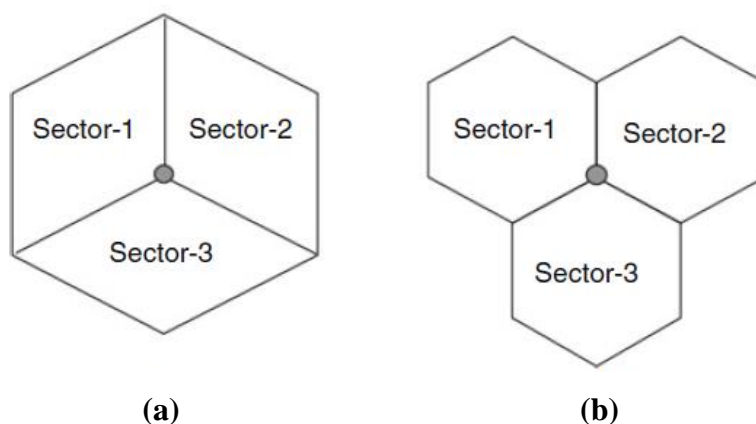

Figure 2.5 - Illustration of 120° sectorization (a) Cluster of three Cells (b) Cluster of seven cells [8]

2.3.3 Channel Configuration in GSM

The air interface has two types of channels: physical and logical [6, 9]. Physical channels are all the time slots of the BTS. Again, there are two types: half-rate (HR) and full-rate (FR) (FR). The FR channel is a 13-kbps coded speech or data channel with raw data rates of 9.6, 4.8, or 2.6 kbps, whereas the HR channel provides 7, 4.8, or 2.4 kbps. The logical channel refers to the exact type of data that the physical channel transports. There are two types of logical channels: traffic (TCH) and control (CC) (CCH). User data (speech/data) is carried over traffic channels, whereas signaling and control information is carried via control channels. There are two types of logical control channels: common and dedicated.

The control channel types are summarized in Table 2.1.

Table 2.1 - Control channels [6]

Channel	Abbreviation	Function/application
Access grant channel (DL)	AGCH	Resource allocation, i.e, subscriber access authorization
Broadcast common control channel (DL)	BCCH	Dissemination of general information
Cell broadcast channel (DL)	CBCH	Transmits the cell broadcast messages
Fast associated control channel (UL/DL)	FACCH	For user network signaling
Paging channel (DL)	PCH	Paging for a mobile terminal
Randon access channel (UL)	RACH	Resource request made by mobile
Slow associated control channel (UL/DL)	SACCH	Used for transport of radio layer parameters
Standalone dedicated control channel (UL/DL)	SDCCH	For user network signaling
Synchronization channel (DL)	SCH	Synchronization of mobile terminal

2.3.3 Radio Network Planning Process

The primary goal of radio network planning is to create a cost-effective radio network solution in terms of coverage, capacity, and quality. Depending on the dominant aspect, such as capacity or coverage, the network planning process and design standards differ from region to region. The radio network design process is not the only process in the overall network design; it must work in tandem with the core and, in particular, transmission network planning procedures. Figure 2.6 depicts a simplified procedure for radio network planning for clarity [6].

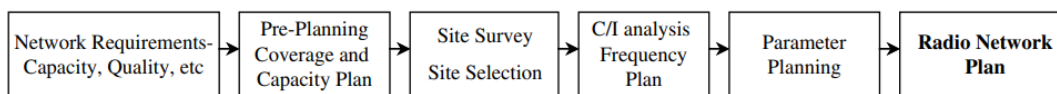

Figure 2.6 - Radio Network Planning Process [6]

2.4 Basics of Radio Network Optimization

The radio network is optimized as part of the network planning process. The main goal of this procedure is to monitor, verify, and improve the functioning of radio network. Because the cellular network spans such a broad region and serves such a big number of people, there are numerous variables that must be regularly checked and addressed in order to maintain network coverage, capacity, and quality. Beyond this, the network is always in a growth phase, i.e., subscriber numbers are continually expanding, traffic is increasing, the establishment of new retail centers means that capacity requirements at these “hotspots” are increasing, and so on. This means that the optimization process should be carried out in the network at regular intervals, resulting in increased network efficiency and income generation [6].

Coverage, capacity, and frequency planning are the three key aspects that radio network planners concentrate on. They proceed to the rest of the activities based on these three, such as location selection, parameter planning, and so on. The same criteria are prioritized in the optimization process: coverage, capacity, and frequency planning. The only difference now is that sites have been chosen and antenna placements have been determined, but the subscriber remains as mobile as ever, with continued expansion.

With the lengthening interval between launch and radio network optimization, optimization duties become increasingly arduous. After a radio network has been designed, it is evaluated for performance. This is accomplished by monitoring the network and comparing it to the key performance metrics established. The outcome (parameters) of fine tuning is subsequently applied to the network to achieve the desired performance. Figure 2.7 shows how optimization can be thought of as a distinct process or as part of the network planning process. Power control, quality, handovers, subscriber traffic, and resource availability (and access) measures are all areas where radio network optimization is focused.

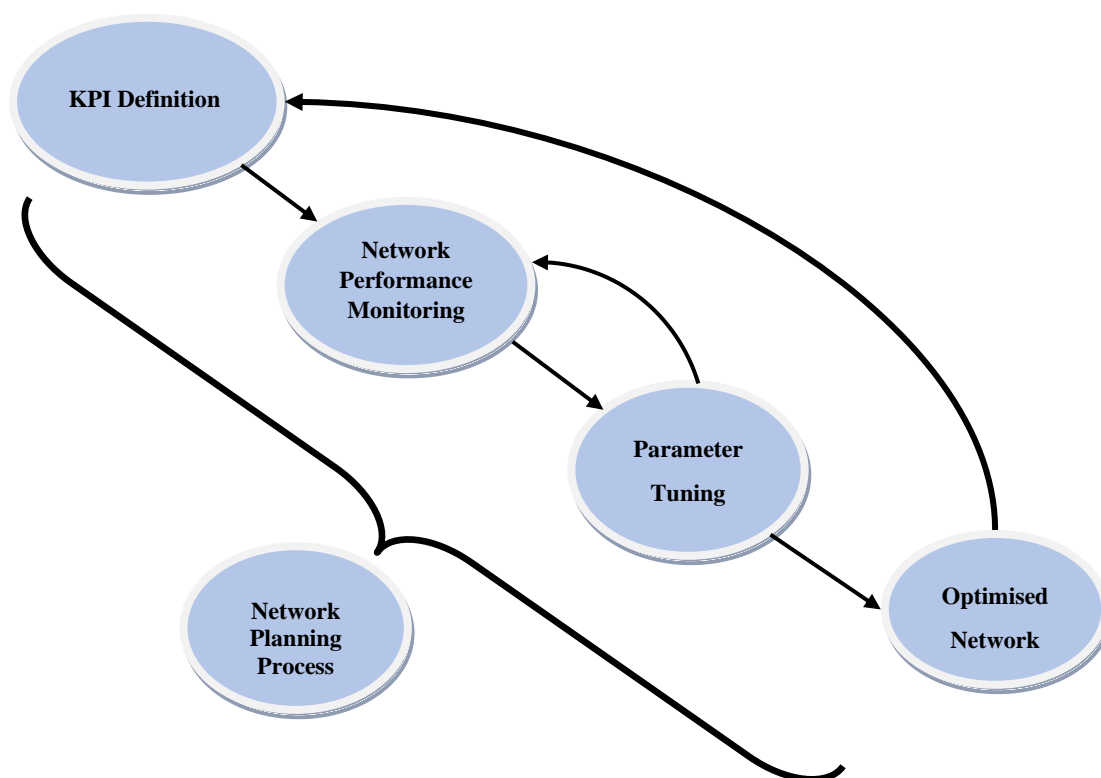

Figure 2.7 - Radio network optimization [6]

2.4.1 Key Performance Indicators

Key performance indicators, or KPIs, are required for radio network optimization (or any other network optimization for that matter). When the network monitoring process is in progress, these KPIs are parameters that should be closely monitored. The term KPI is most commonly applied to characteristics linked to voice and data channels. Coverage, capacity, and quality criteria, which include both speech and data, can be used to characterize network performance.

2.4.2 Network Performance Monitoring

Monitoring the performance of important parameters and assessing the performance of these parameters in terms of capacity and coverage are two processes in the network performance monitoring process. The radio planners must first integrate the information/parameters that they must monitor. The KPIs are gathered in conjunction with outdoor measurements like drive testing. This is also accomplished through the use of tools. The instruments used for field measurements include those that can analyze call traffic,

capacity, and quality, as well as the network as a whole. A mobile phone, referred to as a “test mobile,” is also utilized for drive testing.

This phone continues to make calls while in a moving vehicle that travels through the network. The network’s quality can be assessed using DCR, CSR, HO, and other measures. The network management system can also create measurements in addition to drive testing. Finally, once the erroneous parameters have been identified and the proper values have been found, the radio planner enters them into the network planning tool to evaluate the change before they are changed/implemented in the field.

2.4.3 Network Performance Assessment

The performance of network can be judged by how well the essential parameters of coverage, capacity, and quality are performing. The performance indicators are [6]:

- ✓ Amount of traffic and blocking,
- ✓ Resource availability and access measurements,
- ✓ Handovers (same cell/adjacent cell, success and failure) measurements,
- ✓ Receiver level and quality measurements,
- ✓ Power control measurements.

2.5 Transmission Network Optimization

2.5.1 Basics of Transmission Network Optimization

Switch and signaling network optimization are both part of core network optimization. The process begins with the definition of key performance indicator definitions as well as data collecting. After that, the information gathered is analyzed. Both the switch and signaling parts of the network are analyzed for performance. The transmission network (for the core) and other features such as IN may be included in some circumstances, as well as their influence on the core network.

An examination of the network and data may reveal bottlenecks and lead to recommendations for network upgrades or parameter adjustment. These modifications are then made/suggested for adoption in the final core network optimization plan.

2.5.2 Transmission Network Optimization Process

There are often two basic reasons (issues) for transmission network optimization: either the capacity is insufficient or the quality is not up to par. The optimization definition and procedure, network problem analysis, and solution formulation are all based on one or all of these issues. The key performance indicators (KPIs) should be chosen after the main problem

has been identified. The major KPIs in a transmission network are ESR and SESR, which measure the quality of microwave lines. Aside from that, during a synchronization investigation, some metrics such as slip frequency can be examined.

2.6 Core Network Optimization

2.6.1 Basics of the Optimization Process

Switch and signaling network optimizations are both part of core network optimization. The process begins with data collection and the definition of key performance indicators (KPIs). After that, the information is analyzed. Both the switches and the signaling are subjected to a performance evaluation. The transmission network (for the core) and other features such as IN may be included in some circumstances, as well as their influence on the core network. An examination of the network and data may reveal bottlenecks and lead to recommendations for network upgrades or parameter adjustment. These corrections are then made/suggested for adoption in the final core network optimization plan. Any information that is relevant to the network's quality of service can be included in the key performance indicators. This could include parameters like traffic and signaling performance, as well as measurements like HLR, VLR, and other key network elements. Data can be acquired using test equipment, counters on the NMS, or other network measurements/reports.

2.6.2 Data Collection and Analysis

2.6.2.1 Data Collection : Switching

Optimization in the core network is dependent mainly on traffic measurement inputs, which is also the most critical input for the whole process. This data mainly consists of information related to the existing network elements and the interconnections between them (as this will be the basis of routing analysis and optimization). The network in general should have a nomenclature consistency for the efficient network performance.

2.6.2.2 Data Collection: Signaling

The signaling optimization procedure is built on top of the existing signaling strategy. The NMS can be used to collect information about the performance of signaling links. All of the signaling elements in the core network should have their measurements and statistics obtained. This can be done with the use of statistical counters for monitoring the performance of signaling network.

2.6.2.3 Data Analysis: Switching and Signaling

After the data has been collected, it must be analyzed. Suggestions for changes and optimization must be made based on the analysis. The inputs for analysis are traffic measurement reports. Typically, traffic is separated into individual types during the planning phase, such as traffic that originates and terminates in the network, traffic that originates and terminates in an external network, internal and transit traffic, and so on. This type of traffic distribution division would make the analysis much easier.

Traffic and signaling analysis would result in information such as:

- ✓ Traffic handled by switches/exchanges.
- ✓ Exact traffic volume for each traffic class.
- ✓ Measurements relating to subscriber calling (subscribers/calls/successful call attempts/traffic intensity).
- ✓ The amount of traffic flowing via switching exchanges and the availability of those exchanges (leading to congestion figures).
- ✓ The signaling network configuration.
- ✓ Load on the signaling network.

The following phase in the optimization process, which leads to the final optimization plans, is to make improvement suggestions based on the above analysis.

2.6.3 Core Network Optimization Plan

The optimization plan is made up of suggestions to improve the core network quality after the investigation. This usually includes ideas for both the switch and the signaling:

- ***Switch networks optimization plan***
 - If a congestion problem is discovered, additional PCM connections should be recommended at the congestion location. It should be considered if the congestion is severe and a new switch is necessary. This would require planning engineers to create a complete network topology with information such as the new switch's placement, traffic routed via it, and so on.
 - In locations/regions where the transit switch is handling excessive traffic, the inter-switch connection and traffic routing between the MSC and transit switches should be changed. This would necessitate the creation of new routing plans.
 - Mismatches in naming conventions may occur as the networks are deployed. One of the outcomes of the optimization process is the clearing of the 'name mess,' and the naming standard should be consistent throughout the network.

- ***Signaling network optimization plan***

- The number of signaling links should be optimized, with increases or decreases made as needed. Signaling links and SLS should be evenly spread throughout the network. New signaling links and link sets should be proposed if it is not uniform.
- Normally, load distribution is not equal. It's time to build new signaling plans and network topologies.
- Proposals for signaling control unit redundancy should be provided.

2.7 Conclusion

In this chapter, we gave an overview of GSM network optimization, and introduce some basic concepts that will be used in the subsequent chapter. At the beginning, we presented briefly some basics of network planning. After that, we discussed the fundamentals of network optimization, and characteristics of a transmission network traffic optimization. In the following chapter, we will apply some discussed concepts here in order to enhance the quality of services in a specific GSM network in the city of M'Sila.

***Chapter 3 : Optimization of GSM Network
Services in M'Sila City***

3.1 Introduction

This chapter concerns the optimization of the quality of service in the GSM network of the City of M'Sila. In particular, it provides a solution for a real case in one of its important streets which had a congestion problem, by using WEBLCT and U2000 software tools. The chapter is initiated by an analysis of the area concerned by the study in order to identify the problems and propose a solution. After that, we give a brief description of the optimization tools and approaches. Then, we show and discuss the results obtained after the application of the proposed solution.

3.2 Analysis the zone of study

Statistics from the BSCs of M'Sila indicate a degradation in the performance of the GSM network in terms of quality of service the Street of Ouaua El Madani, M'Sila city (GPS Localization: $35^{\circ}42'39''N$ $4^{\circ}32'25''E$), which has increased the number of subscribers who call to complain about call set-up problems, call cuts, etc. The Figure 3.1 shows the geographical map showing the position of the degraded site 28669 and there farend site 28501, in addition the link between both sites is FHN with (1+1) configuration, the last one meaning the link has a hardware protection (1 work and the other standby).



Figure 3.1 - Geographical map of the position of the degraded site 28669 and the farend site 28501

It may be noted that the street has a rooftop BTS that covers the area, the BTS type is outdoor (BTS 3900 A) with three sectors, each one has self-azimuth in order to cover all clients.

The ATM Mobilis maintenance team of the UOP M'Sila informed by the network supervisor engineer that an issue is on the site 28669. In fact, the network supervisor has a specific software named PRS. However, the PRS centrally manages the network devices in the GSM BSS, UMTS RAN, LTE RAN, WLAN, CDMA BSS, WiMAX RAN, TD-SCDMA RAN, Single RAN, and core network (CN). The PRS also provides the following solutions: traditional KPI Insight–centered network performance analysis, end-to-end capacity resource visibility, PS MBB service traffic visibility, and user experience visibility. It gives operators insights into MBB network quality and helps operators maximize the value of their network assets.

After investigation operations, the infected KPI's are R9109 and T66008 as illustrated in the Figures 3.2 and 3.3 respectively. Therefore, the main issue was in the unsuccessful Application Attempts due to the lack of idle timeslots.

R9109: Number of Unsuccessful Application Attempts of Abis Timeslot Because of no Idle Timeslot.

And T66008: Average Number of Available Flex Timeslots

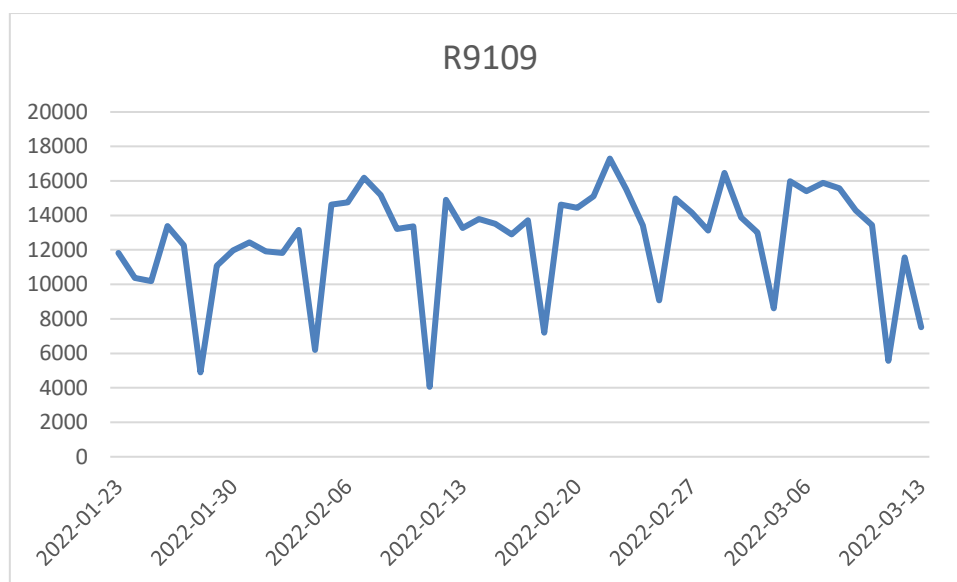

Figure 3.2 - R9109 Line before Optimization Operation

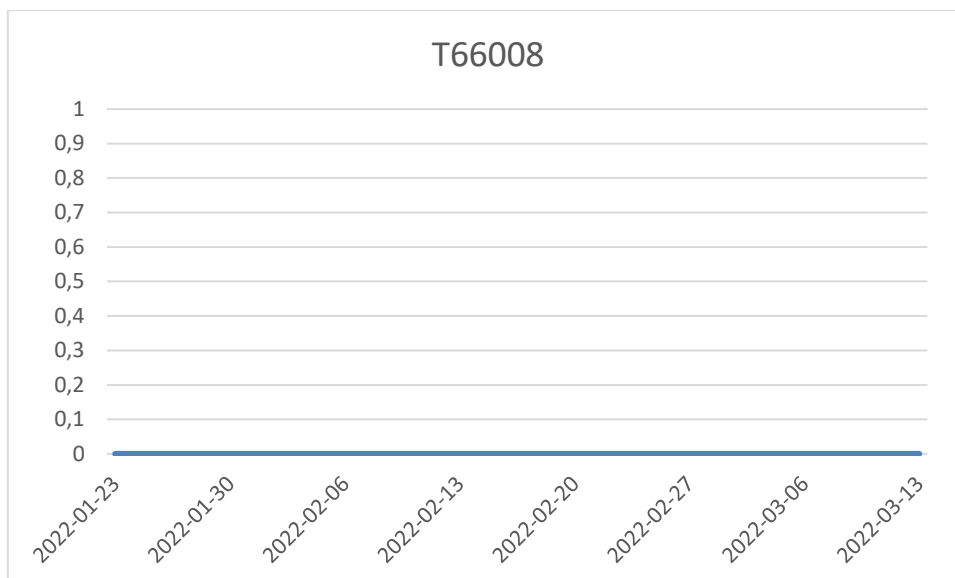

Figure 3.3 - T66008 line before optimization operation

According to these two figures, it can be shown that the problem was on the link congestion (28669 TO 28501). Hence, to deal with, the optimization of the link by adding an E1 is mandatory in order to solve this problem.

The E1 is a 2.048 Mbps point-to-point dedicated, digital circuit provided by the telephone companies in Europe. E1 is the European counterpart of the North American T1 line, which transmits at 1.544 Mbps, and E1 and T1 lines can be interconnected for international use. E2 through E5 lines provide multiple E1 channels.

An E1 line uses two wire pairs (one for transmit, one for receive) and time division multiplexing (TDM) to interleave 32 64-Kbps voice or data channels. The E1 link or circuit is probably the most commonly used format within the E carrier system.

3.3 Description of the optimization tool and procedure

3.3.2 Presentation of the optimization tool

- *Description of U2000*

Huawei mobile network elements (NEs), including LTE/EPC NEs, are managed centrally using the iManager U2000. Configuration management, performance management, fault management, security management, log management, topology management, software management, and system management are all included in the U2000. It also has a number of optional features.

- *Description of WEBLCT*

At the NE layer, Huawei LCT includes a plethora of management functions:

- Search for links in NE management.

- Add/remove NEs.
- Activate or deactivate NEs.

Management of alarms:

- Defining alarm monitoring strategies.
- Add/remove NEs.
- NEs are connected or disconnected.
- View your alarms.
- Delete alerts

Managing performance:

- Defining tactics for performance monitoring.
- View the results of the event.
- Perform a reset of the performance registers.

Configuration management:

- Basic link information configuration.
- Configuration of radio links is required.
- Protection Configuration
- Configuration of the interface
- Configuration of the service
- Configuration of the clock

Communication management:

- Management of parameters and communication.
- DCC management.
- IP protocol management.
- OSI protocol management.

Security management:

- NE user management.
- NE user group management.
- LCT access control.
- Online user management.
- NE security setting.
- NE security log.
- NMS user management.

- NMS log management

3.3.3 Optimization procedure

The Figure 3.4 illustrate a hardware overview of the concerned site 28669, the figures 3.4(a) and 3.4(d) represent the rooftop pol that the antennas installed, and the 0.6 m antenna with (1+ 1) ODUs respectively. Furthermore, the figures 3.4(b) and 3.4(c) shows the hardware installation of the outdoor BTS cabinet and the different devices installed in the cabinet such as the BBU, RTN910, DDF, MRFU, WRFU ... etc.

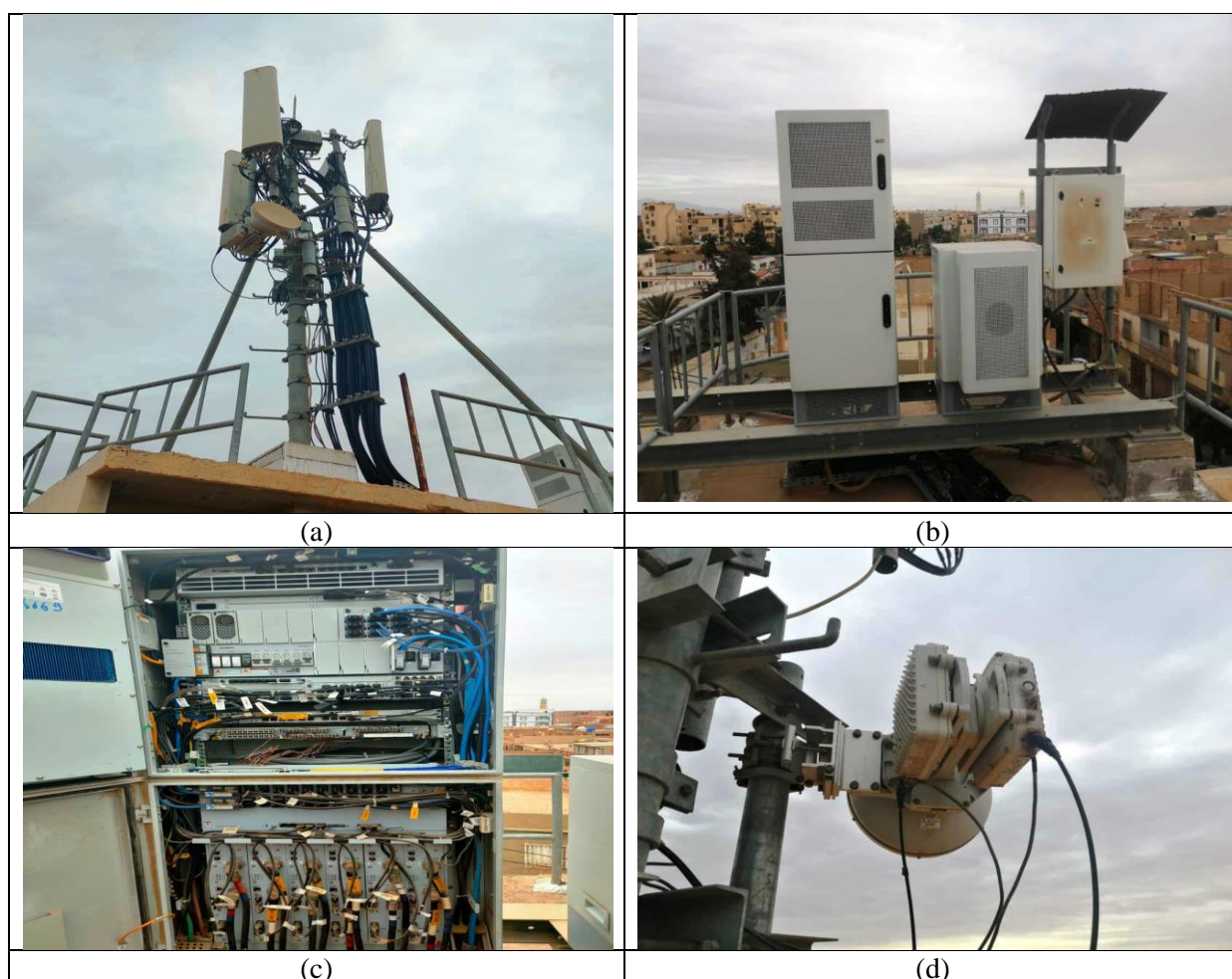

Figure 3.4 - Site overview (a) Rooftop pole (b) Outdoor BTS cabinet, (c) TX and radio devices, and (d) Antenna 0.6 m with ODUs

The figure 3.5 indicate an overview of the RTN 910 installed in the degraded site 28669, the Web Lct software is used to check and operate the concerned link 28699 TO

28501. The RNT 910 has only four slots, it usually used in the terminal site like this site. The slots are occupied as following:

- **Slot 1:** Control board CSHA.
- **Slot 3:** ISU2 card (Main).
- **Slot 4:** ISU2 card (Standby).
- **Slot 9** (Physically is the slot2): SP3S card for electrical connection of E1.

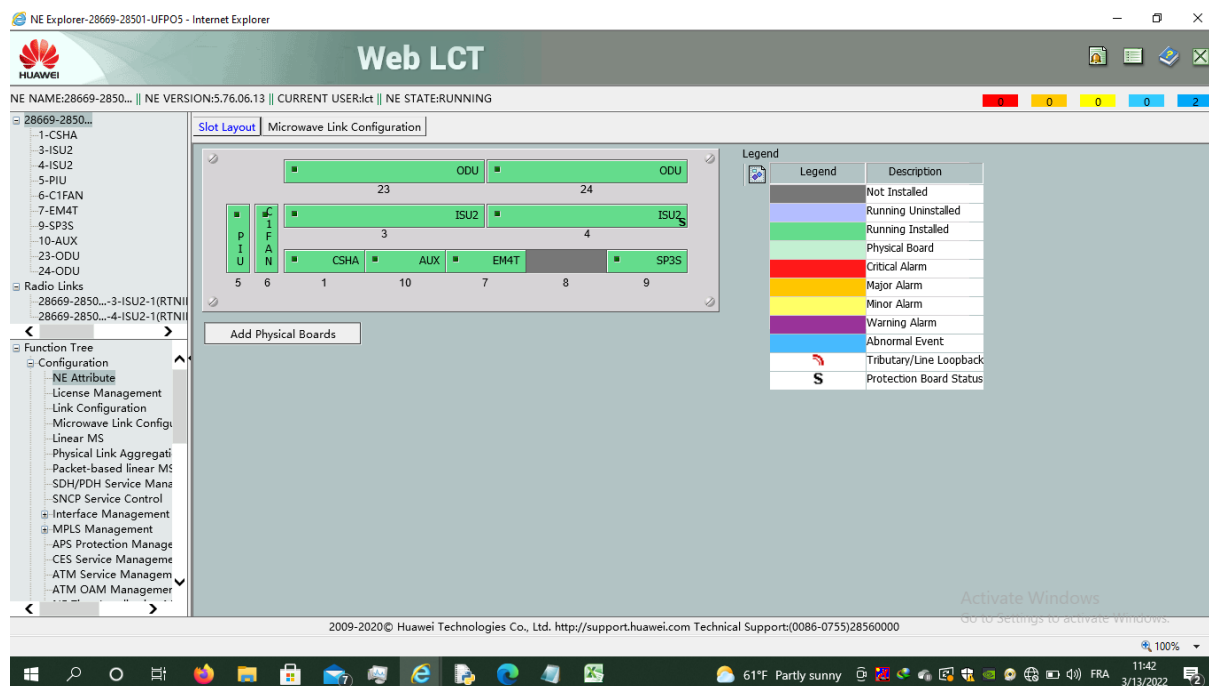

Figure 3.5 - Overview of RTN 910 (28669 side) using WebLCT Software

In order to add a new E1, firstly we interconnect electrically the second E1 from the GTMU (This board is included in the BTS cabinet) board to the SP3S board (slot 2 of RTN 910) using the intermediate DDF (Digital Distribution Frame) as shown in the figure 3.6.

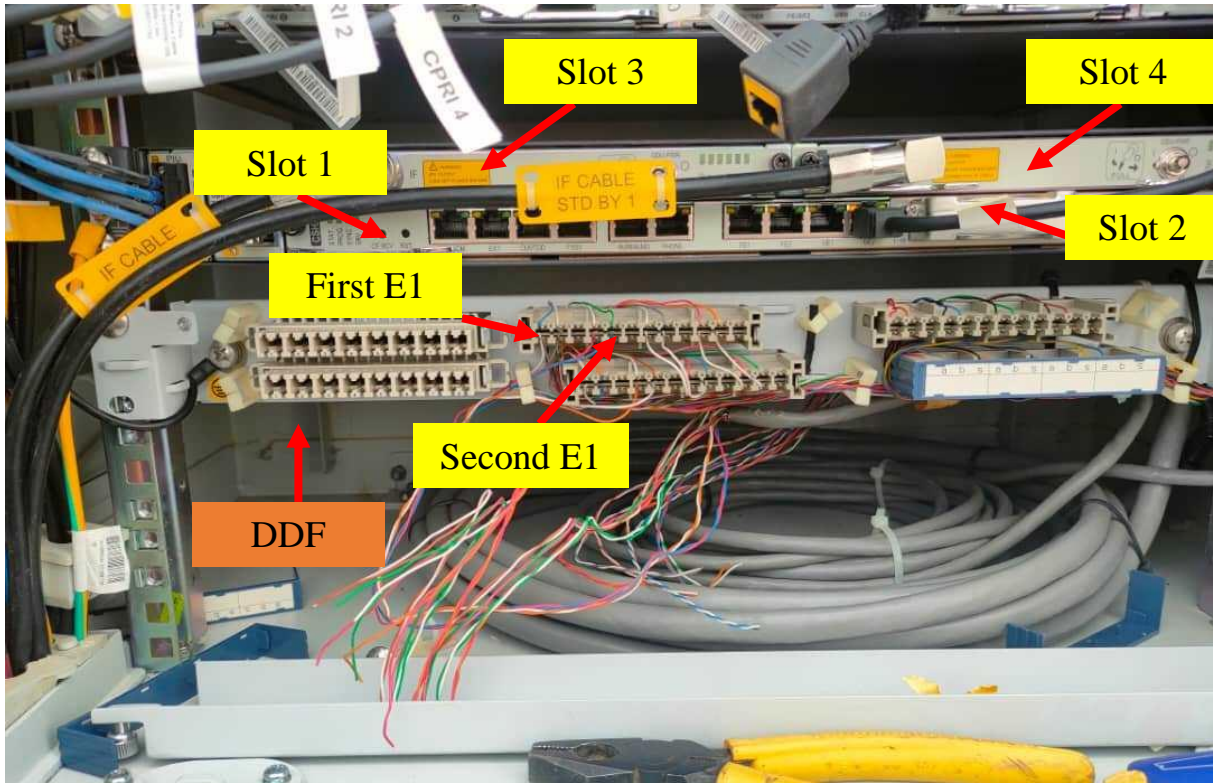

Figure 3.6 - E1 electrical interconnection in the site 28669

In the second steps, a software cross connection is mandatory to routing the second E1. However, the source is 28669 sides and the sink is the farend site 28501.

The figures 3.7 shown the Web LCT interface before make the cross connection, for this, the last one is found in the SDH/PDH Service Management interface.

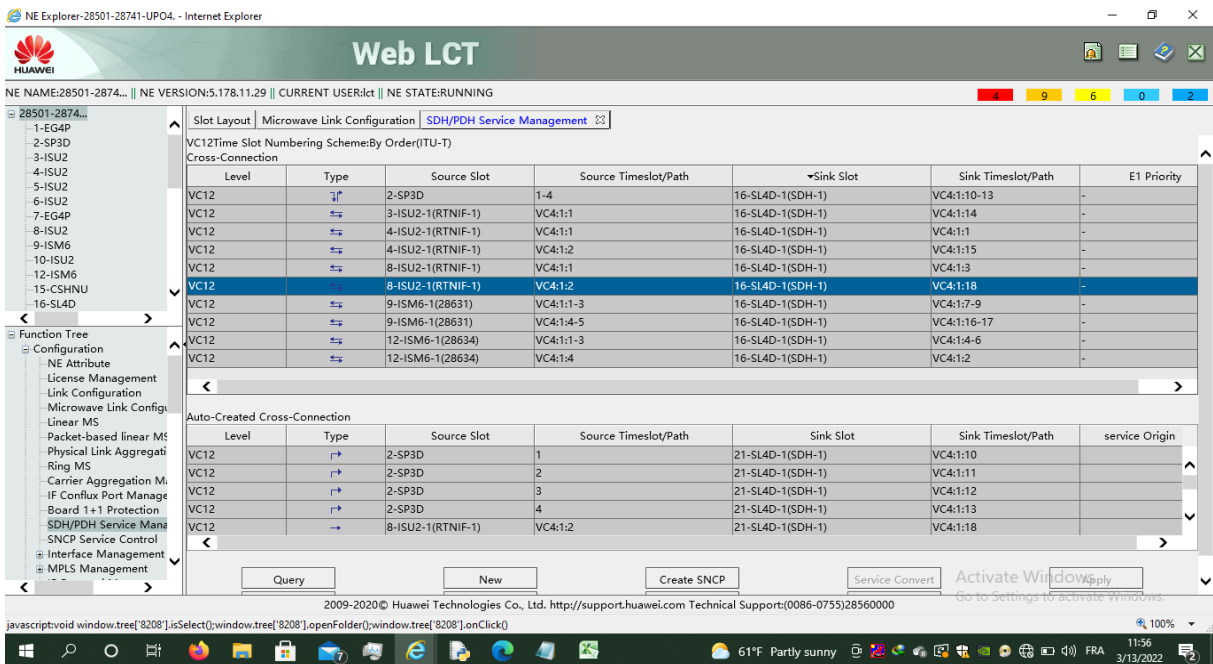

Figure 3.7 - SDH/PDH Service Management interface

As illustrate in the figure 3.8, the main steps are represented in order to create a cross connection between two boards in the RTN 980 (28501 side). Indeed, the source slot is SL1D board number 1, timeslot number 33, however the sink slot is also SL1D, but board number 21, timeslot number 62. The figure 3.9 indicate the resulting E1 software cross connection.

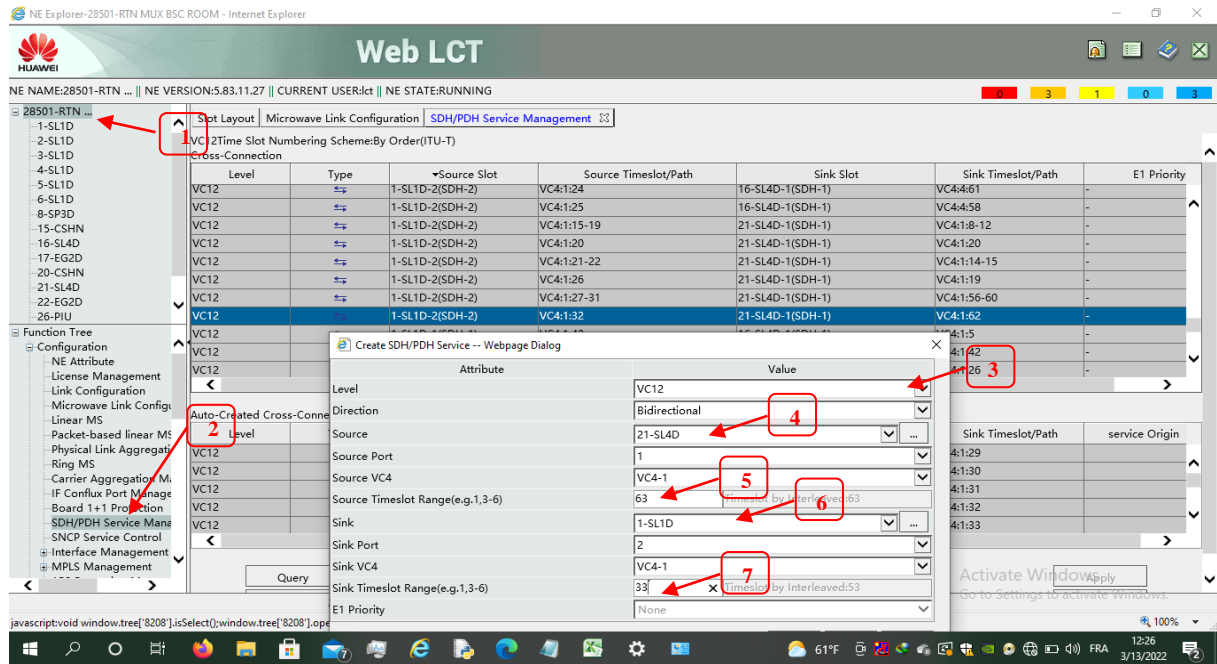

Figure 3.8 - Steps of create cross connection

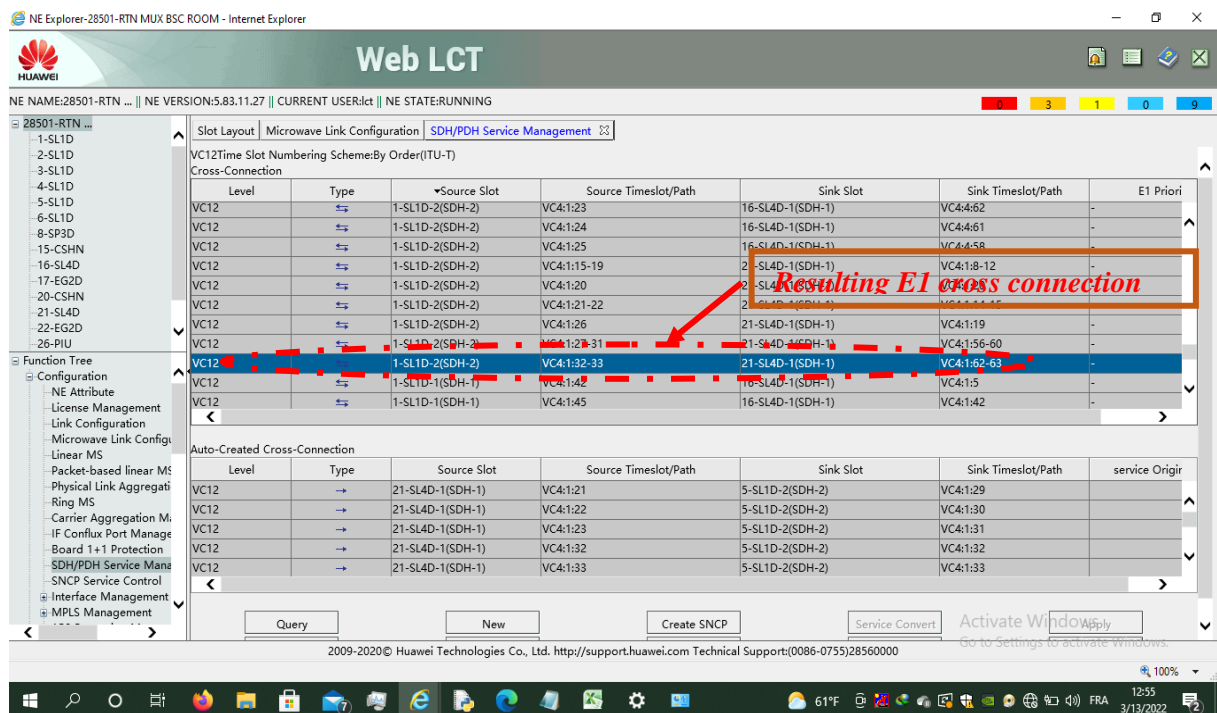

Figure 3.9 - Resulting E1 software cross connection

3.4 Optimization of KPI's in M'Sila city

As shown in the figure 3.10 that represent a study comparative of KPI R9109 before and after the optimization operations mentioned in the above section. Therefore, before fixed the transmission issue, the number of the failed applications goes to 15104 per day recorded in 21/02/2022. However, after our intervention by adding a second E1 to fix the bottleneck faced in the Abis, the results are showing a good performance that have NO failed application since the day of the intervention (13/03/2022).

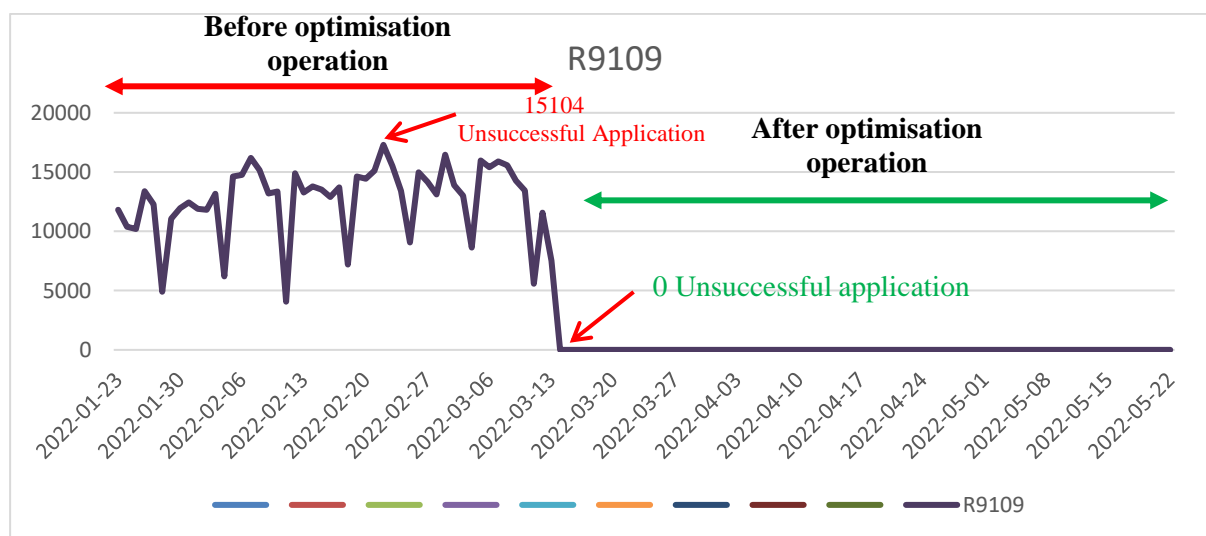

Figure 3.10 - R9109 Before and after optimization operation

In same way, the figure 3.11 represents also the optimization of the KPI T66008 before and after the operation. Indeed, this KPI indicate the average of the number of available flex timeslots. Therefore, before our intervention to fix the TX problem, the average of the available flex timeslots is null. However, after optimization operations by adding a second E1 to fix the bottleneck faced in the Abis congestion, the operation was succeeded with reservation of more than 370 timeslots in the first month, than the number was increased into 450 available flex.

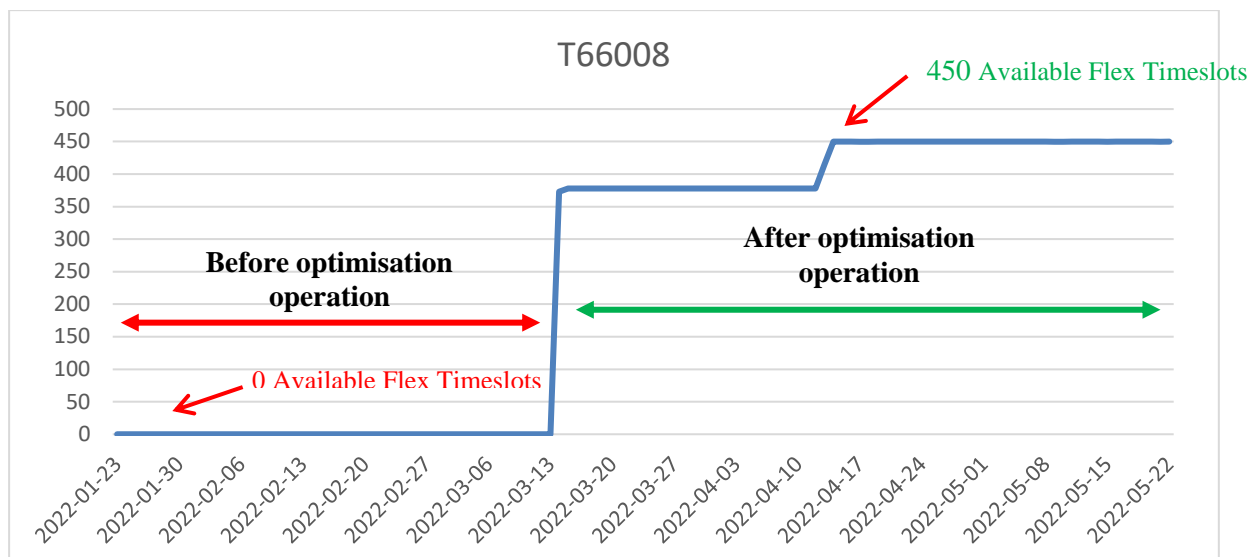

Figure 3.11 - T66008 Before and after optimization

3.5 Conclusion

In this chapter, we present some results about the implementation of the new optimization procedure in a real GSM network of the national mobile operator Mobilis ATM, in the city of M'Sila. In doing so, we made a decision of augmenting the E1 in order to enhance the quality of services. By analyzing the obtained results, we can conclude that the applied optimization procedure is very efficient and successful, where the number of failed application attempts (calls, SMS, ... etc) is reduced significantly, and thousands of idle timeslots are becoming free consequently. This yields to enhance greatly the quality of services in GSM network in one of the biggest streets in M'Sila city.

Conclusion and future works

Conclusion:

In this dissertation we discussed several issues related to the quality of services in GSM network in one of the biggest streets of M'Sila City. This dissertation is a combination of theoretical study and practical tasks which are carried out on site. During our training, we worked under the supervision of the ATM Mobilis maintenance team in order to enhance the performance of the 2G GSM network in this street.

In the first chapter of this dissertation, we gave a brief description of the characteristics of the GSM network and discuss also some theoretical concepts related to the discussed issues. After that, chapter two discusses the cellular network concept, the optimization of transmission network and presents key factors which has to be taken into account in order to improve the quality of services in a 2G GSM network. Finally, chapter three presented an optimization procedure that had been implemented in the 2G GSM network of the national mobile operator Mobilis in the city of M'Sila and gave also some results.

We can conclude according to the obtained results that the applied optimization procedure is very efficient and successful, where the number of failed application attempts is reduced significantly, and thousands of idle timeslots are becoming free consequently. Obtained results show the efficiency of the proposed procedure and the quality of services is remarkably enhanced. Hence, with this procedure, it is possible to increase the number of mobile subscribers while keeping the subscribers satisfied by the delivered quality of services.

Future works:

Based upon the presented results, the research topic of this dissertation can take different directions:

- ✓ Possibility of improvement can vary from employing more parameters as PoI from the handover algorithm, improving the simulator, and to further statistical/analytical studying live networks data.
- ✓ Similarly, adding more E1 can optimize the GSM network by reducing the PoI congestion and improving the call success rate.
- ✓ Further analysis of traffic will be much desired in order to ignore short term variations in the traffic during the peak hour and to maintain the utilization.

Appendix

Appendix: iManager U2000 Web LCT

1. System Overview

This appendix describes the position of the Web LCT in the telecommunication management network (TMN) hierarchy, the product characteristics, and the manageable equipment of the U2000 WebLCT V100R003C00.

2. Network Position

The Web LCT is an NE-level management system in an optical transport network. Based on the browser/server architecture, the Web LCT allows you to perform all operations of NE-level configuration and maintenance. In the telecommunication management network (TMN), the Web LCT is located at the NE layer. That is, the Web LCT is an element management system (EMS) and provides all management functions at the NE layer. See Figure 1.

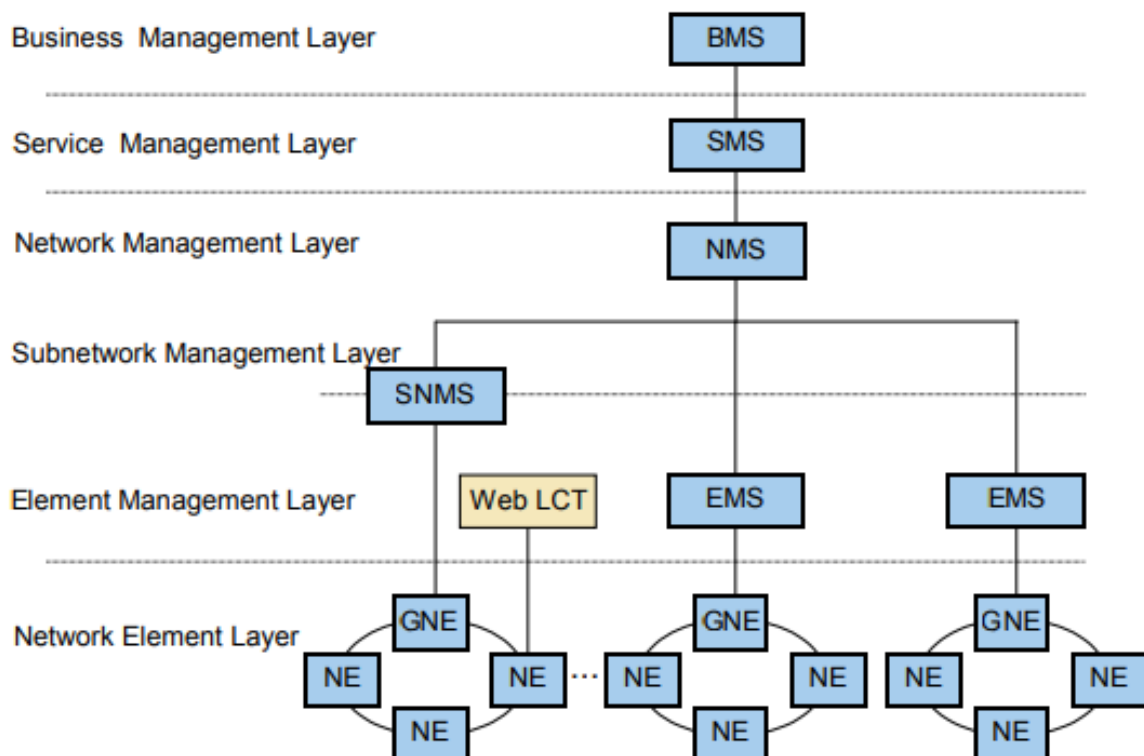

Figure 1 - Position in TMN Hierarchy

BMS: Business Management System

SMS: Service Management System

NMS: Network Management System

SNMS: Subnetwork Management System

EMS: Element Management System

GNE: Gateway Network Element

NE: Network Element

The Web LCT accesses a local NE through a LAN or a serial port, and accesses a remote NE through data communications channel (DCC). The Web LCT can be integrated with the U2000.

3. Function Comparison Between Web LCT and U2000 LCT

The Web LCT and the U2000 LCT are EMS. They provide the ability to configure and maintain Huawei OptiX series products, and the ability to manage alarms, configuration, performance data, security and communication.

The main difference between the Web LCT and the U2000 LCT is as follows:

3.1 Manageable Equipment

The Web LCT manages Huawei NG WDM series, RTN series, WDM (NA) series and submarine line monitor products. The U2000 LCT manages SDH series, PTN series, MSTP series, OSN series, Metro WDM series, LH WDM series and submarine line monitor products.

3.2 GUI Style

The Web LCT uses the browser/server architecture that the user configures and maintains Nes by using a browser. The Web LCT implements a web-based graphic user interface. The U2000 LCT implements a Java-based graphic user interface.

3.3 Data Management

The Web LCT has no NM database, all operations are directly applies to NEs. Hence, the Web LCT does not support the ability to preconfigure an NE, upload and download the NE configuration data, and acknowledge and synchronize alarms.

4. Features and Functions

The Web LCT provides management functions at the NE layer.

4.1 Alarm Management

The alarm management function monitors faults and abnormal events generated during running of the equipment in real time, and also provides alarm details and analysis measures.

This helps you locate and clear faults in a fast manner. The Web LCT provides alarm management functions. You can customize alarm monitoring policies as required, and analyze and process the alarms.

4.2 Performance Management

The performance management function collects performance data of the equipment, functions, services, or other objects periodically or after being triggered, to record the operation status, health status, and quality of service (QoS) of a network. The Web LCT provides performance management functions. You can customize performance monitoring policies as required, and analyze and process the collected performance data.

4.3 Security Management

The security management function includes Web LCT security management, NE security management and operation log management. This ensures the security of the Web LCT system and the transport network data.

4.4 Communication Management

The Web LCT provides communication management function. The communication management function provides a communication channel for operation, management and maintenance (OAM) of the transport network.

4.5 Time Localization Management

Time localization ensures that the time on the Web LCT is correctly displayed when the Web LCT crosses time zones and daylight saving time (DST).

4.6 Report Management

The Web LCT has comprehensive reporting capabilities. The Web LCT user is able to print desired data while viewing them. The report in table format supports filtering by equipment type and can be saved in Excel format.

4.7 WDM NE Management

Network element (NE) management consists of the attribute, communication, service, protection, and clock configurations of each single NE. The configuration data is stored in the database of the Web LCT and the database of the corresponding NE.

4.8 WDM ASON Management

ASON is a new generation of optical network that integrates the exchange and transport. After the user initiates a service request, the ASON selects a route automatically, establishes and removes connections through the signaling control, and performs network connections automatically and dynamically. An ASON NE refers to the equipment that is equipped with

both WDM and ASON features. An ASON network is managed by the Web LCT that combines ASON and WDM features.

4.9 WDM NE (NA) Management

NE management consists of the attribute, communication, service, protection, and clock configurations of each single NE. The configuration data is stored at the NE layer on the Web LCT and in the database of the corresponding NE.

4.10 RTN NE Management

NE management refers to the management of configurations of an NE in terms of attributes, communication, services, protection, and clocks. The configuration object is a single NE. The data is saved to the Web LCT NE layer database and to the NE database.

References

- [1] V. V. Wong and Leung, "Location management for next-generation personal," *IEEE Networks*, pp. 18-24, 2000.
- [2] J. Z. K. W. S. a. S. B. S. G. Miao, "User association and Handover in Fundamentals of Wireless Data Networks, Stockholm, Course notes for (IK2510) at KTH,," Course notes for (IK2510), Stockholm, 2014.
- [3] A. Bazzari, "Handover optimization in GSM," Royal Institute of Technology, 2015.
- [4] R. Cisco, "Cisco Annual Internet Report (2018–2023)," Cisco, 2020.
- [5] J. G. Sempere, "An overview of the GSM system," 2002. [Online]. Available: https://web.fe.up.pt/~mleitao/CMOV/Tecnico/GSM_Sempere.html.
- [6] A. R. Mishra, *Fundamentals of Network Planning and Optimisation 2G/3G/4G: Evolution to 5G*, Glasgow, UK: John Wiley & Sons Ltd, 2018.
- [7] G. Heine, *GSM Networks: Protocols, Terminology, and Implementation*, London: Artech House, 1998.
- [8] S. Faruque, *Radio Frequency Multiple Access Techniques Made Easy*, Cham, Switzerland: Springer International Publishing, 2019.
- [9] H.-J. V. C. B. Joerg Eberspaecher, *GSM: Switching, Services and Protocols*, Chichester: Wiley, 2001.
- [10] S. Telecommunication, "Cells & Clusters," [Online]. Available: <http://simcom07.blogspot.com/2011/08/cells-clusters.html>.

Abstract

We treat through this dissertation the problem of channel optimization in 2G GSM network in M'Sila city. This dissertation is a combination of theoretical study and practical activities which are carried out on site. The objective behind this study was made in order to understand how to optimize a cellular network by taking into account different parameters that come into play in the optimization of this specific network. At the beginning, this dissertation gives a brief description of the characteristics of the GSM network, from the point of view of constitution, operation and propagation of radio waves. After that, the cellular concept and the KPIs, which are key factors in the optimization of a cellular network, have been also discussed. In collaboration with ATM Mobilis maintenance team, we propose an optimization procedure by augmenting E1 in order to overcome the degradation in the performance of GSM network, the bad quality of services (calls set-up problems, calls cuts, ... etc) in one of the biggest streets in M'Sila city. In doing that, we used the WEBLCT software developed by Huawei. Obtained results show the efficiency of the proposed procedure and the quality of services is remarkably enhanced.

Key words: 2G, GSM, Optimization, KPI, WEBLCT.

ملخص

في هذه المدكرة تم تناول موضوع تحسين القنوات الارسال في شبكة GSM لاتصالات الجيل الثاني بمدينة المسيلة. لقد جمعت هذه المدكرة بين البحث النظري والأنشطة العملية التطبيقية على أرض الواقع. الهدف من هذه الدراسة هو معرفة كيفية تحسين الشبكة الخلوية من خلال مراعاة الخصائص المختلفة التي تلعب دوراً عند تحسين هذه الشبكة. تبدأ هذه الرسالة بمناقشة موجزة لخصائص شبكة GSM من حيث بنائها وتشغيلها وكذا شرح كيفية انتشار الموجات الراديوية في مثل هذه الشبكات. بعد ذلك، تمت مناقشة مفهوم خلوية الاتصال ومؤشرات الأداء الرئيسية (KPIs)، وهي عوامل مهمة في تحسين أداء ونوعية الشبكة الخلوية. من خلال هذا العمل، إقترحنا بالشراكة مع فريق الصيانة التابع لشركة ATM Mobilis تقنية تحسين من أجل معالجة مشكلة التدهور في أداء شبكة GSM ، فضلاً عن رداءة جودة الخدمات (مشكلات إعداد المكالمات ، وقطع المكالمات ، وما إلى ذلك) في أحد أكثر شوارع مدينة المسيلة ازدحاماً. استخدمنا برنامج WEBLCT لتحقيق ذلك. تشير النتائج التي تم الحصول عليها إلى أن النهج المقترح فعال ، وأن جودة الخدمات قد تحسنت بشكل ملحوظ.

كلمات مفتاحية: الجيل الثاني 2G ، GSM ، تحسين أداء الشبكات، KPI ، Weblct.